

CERN PSB BEAM TESTS OF CNAO SYNCHROTRON'S DIGITAL LLRF

M. E. Angoletta, A. Findlay, CERN, Geneva, Switzerland
 O. Bourrion, R. Foglio, D. Tourres, C. Vescovi, LPSC, Grenoble, France
 L. Falbo, S. Hunt, CNAO, Pavia, Italy
 C. De Martinis, University of Milan and INFN

Abstract

The Italian National Centre for Oncological hadrontherapy (CNAO), in its final construction phase, uses proton and carbon ion beams to treat patients affected by solid tumours. At the heart of CNAO is a 78-meter circumference synchrotron that accelerates particles to up to 400 MeV/u. The synchrotron relies on a digital LLRF system based upon Digital Signal Processors (DSPs) and Field Programmable Gate Array (FPGA). This system implements cavity servoing and beam control capabilities, such as phase and radial loops. Beam tests of the CNAO synchrotron LLRF system were carried out at CERN's Proton Synchrotron Booster (PSB) in autumn 2007, to verify the combined DSP/FPGA architecture and the beam control capabilities. For this, a prototype version of CNAO's LLRF system was adapted to the PSB requirements. This paper outlines the prototype system layout and describes the tests carried out and their results. In particular, system architecture and beam control capabilities were successfully proven by comparison with the PSB operational beam control system and with the help of several existing beam diagnostic systems.

INTRODUCTION

CNAO's synchrotron [1] will be equipped with a digital LLRF system, following a general LLRF trend [2]. CNAO's LLRF relies on FPGA and DSP digital signal processing and is based on the system developed for CERN's LEIR [3] and commissioned in 2006.

Table 1: PSB vs. CNAO synchrotron characteristics.

Parameter		Unit	PSB	CNAO
Injection	$f_{REV,I}$	MHz	0.599	0.47
	T_I	MeV/u	49.62	7
Extraction	$f_{REV,E}$	MHz	1.746	2.756
	T_E	MeV/u	1374.2	400 (max)
Synchrotron frequency	$f_{S,MIN}$	Hz	470	521
	$f_{S,MAX}$	Hz	2000	1450
Circumference		m	157	78
Acceleration duration		s	0.5	0.77 (max)
dB/dt		T/s	2.3	3 (max)
Harmonic number			1 or 2	1
Accelerated particles			protons	carbon ions, protons, others

Beam tests of the CNAO synchrotron LLRF system were carried out at CERN's PSB in 2007. Implemented features included frequency program, phase and radial loop and radial steering. The PSB is an attractive benchmark for CNAO's system as fully parasitic (for low intensity beams) or dedicated (for medium or high intensity beams) tests can be carried out on PSB ring 4. In addition, PSB and CNAO's synchrotron have a comparable range of revolution frequency f_{REV} and synchrotron frequency f_S values, thus forcing comparable requirement on beam phase and radial loop bandwidths. Table 1 shows a comparison of the two machines general parameters. The CNAO values refer to the acceleration of carbon ion C_{12}^{6+} beams. The extraction energy T_E shown for CNAO is the maximum extraction energy; a pulse-to-pulse extraction energy variation capability is available.

SYSTEM OVERVIEW

A simplified view of the prototype LLRF system used for the PSB tests is shown in Figure 1 (dashed box).

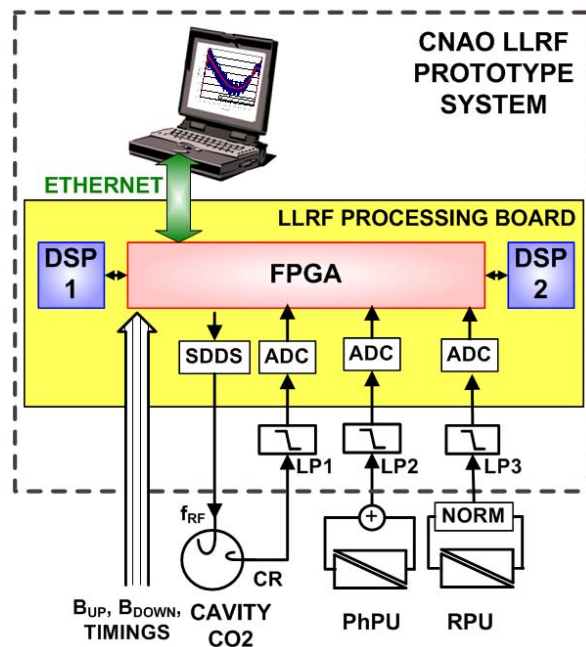

Figure 1: Prototype system layout for the PSB beam tests.

The system receives input signals from the CO2 cavity return (CR), the phase pick-up (PhPU) and the radial pick-up (RPU); these signals are low-pass filtered (boxes LP1 to LP3 in Figure 1), digitized and processed in both the FPGA and DSP 2. In particular, CO2 and PhPU information are acquired as {I, Q} couples, I and Q being respectively the real and the imaginary part of a rotating

complex vector. The B_{UP} and B_{DOWN} signals feed the measured bending field value to the system, thus allowing the implementation of the frequency program. Machine-related hardware timings synchronise control and data acquisition actions to machine operation; software timings derived from the hardware timings determine when loops are closed. The system output is a 10 dBm fixed-amplitude, frequency-modulated signal that drives the CO2 cavity. Neither voltage nor tuning loops are required in the prototype LLRF system as they are implemented separately. The prototype LLRF system was not integrated within the standard PSB controls infrastructure, but was controlled by a standalone laptop connected via Ethernet to the LLRF processing board.

The prototype system was adapted to the signals available in the PSB and to the corresponding electrical formats/levels. For example, the CNAO final LLRF system will directly receive the frequency as a reference function, thus not needing a full frequency program which calculates it from the magnetic field. The CNAO final LLRF system will also implement the cavity voltage and tuning loops in the DSP1, while that part was removed for the PSB tests. More details on the final system hardware, software and signal processing are available in [4].

BEAM CONTROL TESTS

A dedicated proton beam with intensity in the 10^{10} - 10^{12} range was injected in PSB ring four and dumped prior to its extraction. The beam was captured and accelerated at harmonic 1 to the extraction energy. Beam phase and radial loops, frequency program and radial steering were implemented. No synchronisation loop at extraction was implemented as not needed in CNAO, where a slow extraction scheme [5] is planned. This does not require any specific action on the beam control side at extraction. Finally, the system includes many features traditionally implemented with analogue electronics, such as the frequency-dependent phase rotation of PhPU signals to align them with the CR data.

The beam tests proved that the prototype LLRF system captured and accelerated the beam with high efficiency. Additionally, they allowed solving run-time problems, such as the sporadic saturation of one ADC and the excessive time taken by a DSP data transfer.

System Efficiency and Bunch Characteristics

The capture and acceleration efficiencies were measured by taking snapshots of the operational display for the cycles controlled by the prototype system. Measured efficiencies were typically over 95%, in line with those of the PSB operational LLRF system.

Bunch characteristics at extraction energy satisfied the PSB requirements. Figure 2 shows a longitudinal phase space tomogram [6] of a $2.5 \cdot 10^{12}$ particles bunched beam at extraction energy. The largest plot is a two-dimensional histogram of the phase space contents; a colour code indicates the density of particles. The red lines on the two smaller plots are orthogonal projection of the phase space distribution; the black line is the measured bunch profile.

The tomogram shows that the bunch shape is close to Gaussian and that there is a large particle concentration in the bucket centre; other properties such as the momentum spread of $1.81 \cdot 10^{-3}$ and the bunch length of 153 ns are equally satisfactory.

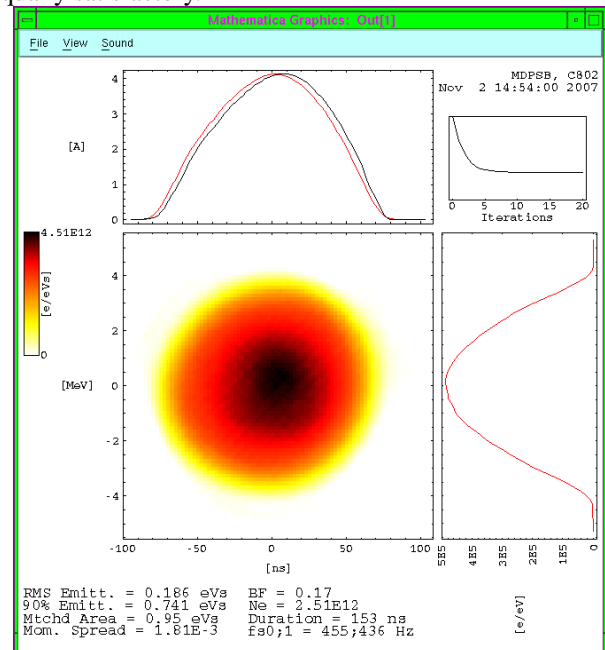

Figure 2: Tomogram of the beam at extraction energy.

Beam Phase Loop

The beam phase loop reduces coherent synchrotron oscillations in the beam and longitudinal emittance growth; additionally, it damps beam loading instabilities. In the PSB tests the beam phase loop sampling period was 5 μ s and the corresponding bandwidth reached 10 kHz without loop instabilities. The beam phase loop input ϕ_m was calculated as the phase difference between CR and PhPU signals, aligned by a software rotation. The phase loop was AC-coupled via a high-pass IIR filter, to reduce static frequency errors. A programmable gain allowed the loop gain, thus its bandwidth, to be varied.

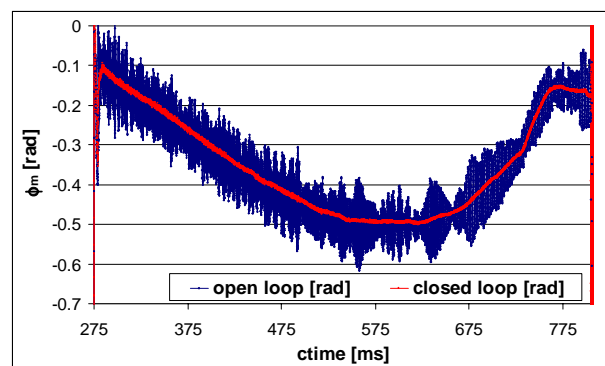

Figure 3: Measured cavity-to-beam phase ϕ_m with beam phase loop open (blue trace) and closed (red trace).

Figure 3 shows the phase loop effectiveness to damp beam oscillations. It displays the cavity-to-beam phase ϕ_m as a function of the time in the beam cycle, called ctime;

ϕ_m was measured with the phase loop open (blue trace) and closed (red trace). The beam intensity was of $2.5 \cdot 10^{11}$ protons in both cases and data was acquired by the on-board FPGA every $45.3 \mu\text{s}$. The oscillation damping is evident by comparing blue and red traces.

Beam Radial Loop and Radial Steering

The radial loop corrects frequency program errors and allows adiabatic control of the beam radial position. In the PSB tests the sampling period of the radial loop was $100 \mu\text{s}$ with a corresponding bandwidth of a few kHz. The radial loop corrector was a Proportional-Integral (PI) regulator with parameters optimised as a function of f_s ; in particular, the PI regulator zero was set so as to cancel the phase loop low frequency pole at a specific ctime. Two different PI setups were available for the same beam cycle. The beam radial position was changed via a radial steering reference function. Figure 4 shows the beam radial position (pink trace) and the cavity drive frequency f_{RF} (blue trace) as a function of ctime, when a 2 mm rectangular radial steering is applied. Data was acquired every $45.3 \mu\text{s}$. The plot shows that the measured beam radial position followed accurately the reference function.

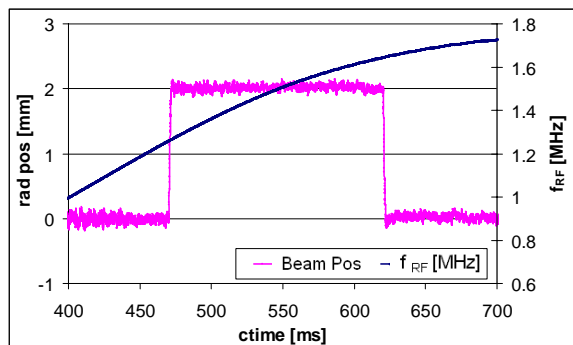

Figure 4: Radial position under rectangular steering (pink trace) and cavity drive frequency f_{RF} (blue trace).

The dominant radial closed loop time constant t_r was checked against its expected value to assess the radial loop dynamics. Figure 5 shows the radial loop response to a position step for various loop gain values. The expected t_r was 1.5 ms for the gain G1, 25% more for gain G2 and 25% less for gain G3; the measured values were in good agreement with those expected.

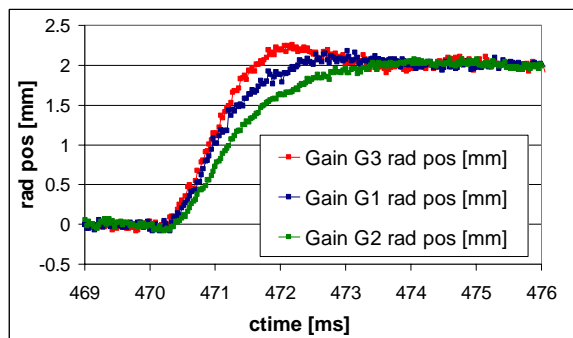

Figure 5: Radial loop response to a position step for different gain values.

The radial steering for the radial loop gain G3 was also observed on the tomoscope “Waterfall” view, shown in Figure 6. The “Waterfall” view generates a mountain range plot of the bunch as seen from above. Figure 6 shows 100 profiles of the same bunch, each profile being taken every 350 turns. The ctime runs vertically from 460 ms (bottom of the plot) to 487.24 ms. The “Waterfall” view shows that the phase change necessary to move the beam that is generated by the radial steering is damped very quickly, in about 1 ms.

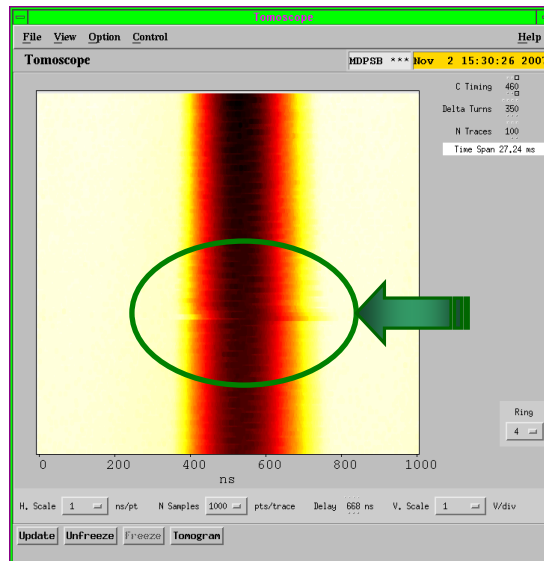

Figure 6: “Waterfall” plot for a 2 mm radial steering.

CONCLUSIONS AND OUTLOOK

CNAO’s digital LLRF system is currently being finalised. A prototype version has been successfully tested with beam in CERN’s PSB. This paper gave an overview of the tests layout and results. Many system capabilities were validated and run-time problems solved. The tests were successful and proved the beam control system performance and flexibility, in view of CNAO’s synchrotron commissioning phase and future operation.

REFERENCES

- [1] M. Pullia, “Status Report on the Centro Nazionale di Adroterapia Oncologica (CNAO)”, paper TUOCG02, this conference.
- [2] M. E. Angoletta, “Digital Low-Level RF”, EPAC’06, Edinburgh, June 2006, p. 1847.
- [3] M. E. Angoletta, A. Findlay, “First Experience with the New LEIR Digital Beam Control System”, AB-Note-2006-003-RF, CERN, 2006.
- [4] O. Bourrion et al., “LLRF Electronics for the CNAO Synchrotron”, paper TUPC139, this conference.
- [5] P. J. Bryant et al., “PIMMS Proton-Ions Medical Machine Study”, yellow report, CERN 2000-006, ISBN 92-9083-166-9.
- [6] S. Hancock et al., “Longitudinal Phase Space Tomography with Space Charge”, Phys. Rev. ST Accel. Beams, Volume 3, 124202 (2000).