

## THE NEW LAYOUT OF THE LHC CLEANING INSERTIONS

R. Aßmann, O. Aberle, O. Brüning, S. Chemli, D. Gasser, J.B. Jeanneret, J.M. Jimenez, V. Kain, E. Métral, G. Peon, S. Ramberger, C. Rathjen, T. Risselada, F. Ruggiero, L. Vos, CERN, Geneva, Switzerland, D. Kaltchev, TRIUMF, Vancouver, Canada

### Abstract

The improved LHC collimation system required significant changes in the layout and design of the warm insertions. Requirements for collimation, optics, impedance, vacuum, and additional infrastructure are described and the adopted layout is presented. Various design principles have been explored during the re-design. Magnet positions and collimators were moved significantly, such that a good cleaning efficiency was maintained while impedance was reduced by almost a factor of two. Space for upgrades of the collimation system was reserved (metallic phase 2 collimators would allow for a better efficiency than originally achievable). Scrapers were allocated for beam shaping and diagnostics. The required infrastructure was specified, including a powerful cooling system for the collimators.

### LAYOUT CHANGES WITH THE IMPROVED COLLIMATION SYSTEM

The decisions on an improved LHC collimation system [1] imposed a number of layout changes for the LHC cleaning insertions in points 3 and 7 [2] and provided an opportunity to implement additional layout improvements:

- The two-stage cleaning with its special optics requirements was kept, however introducing additional impedance constraints [3].
- The space requirements per collimator were significantly increased due to longer, low Z jaws and a detailed engineering design. For most collimators and movable absorbers a space of 2.0 m is reserved [4], with the exception of the scrapers which have a space reservation of 1.2 m. Equal space reservations allow to economize in the number of different components, minimizing the overall design and production cost.
- The adoption of a phased approach effectively doubled the number of space reservations for secondary collimators in the cleaning insertions IR3 and IR7. Initially only phase 1 robust collimators will be installed. Later it is foreseen to complement the existing phase 1 collimators with advanced phase 2 designs.
- The number of primary and secondary collimators were reduced by about 30%. The liberated space in IR7 is kept free for an eventual upgrade of the collimation system. The space in IR3 has been given up.

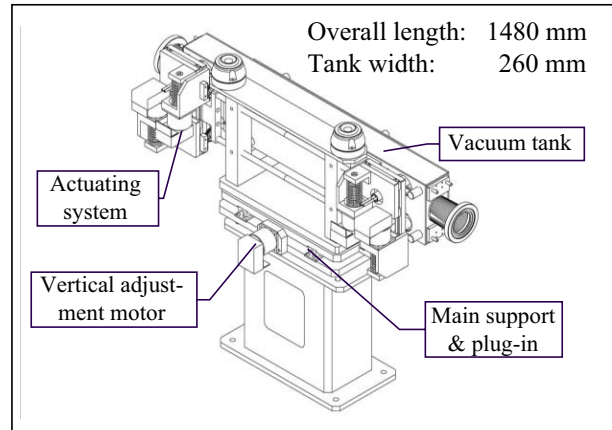

Figure 1: Design view of an LHC secondary collimator.

- The collimators were moved to locations of higher beta functions while keeping good cleaning efficiency. As a result the collimator-induced impedance was almost halved for the same normalized settings of collimators [5]. This was also supported by a slightly modified optics in IR7, providing for less phase advance and slightly higher beta functions.
- Collimator were relocated with the constraint that no longitudinal overlap between collimators for beam 1 and beam 2 occur.
- The new layout and optics was verified at each step to not reduce the available aperture in IR3 and IR7. The aperture was already tight for the old layout and could not be improved [2].
- The inter-module space in the warm quadrupoles was increased from 30 cm to 40 cm, allowing for good positioning of ion pumps and reduction of intervention time.
- The dipole correctors were moved such that they face the IP side of the collimators. They are then much less exposed to beam induced showers from the collimators.
- The quadrupoles were turned such that their connection sides are protected against excessive radiation.

The new layouts for momentum and betatron cleaning insertions were finalized in close collaboration with the machine integration. The final layout of the two insertions is

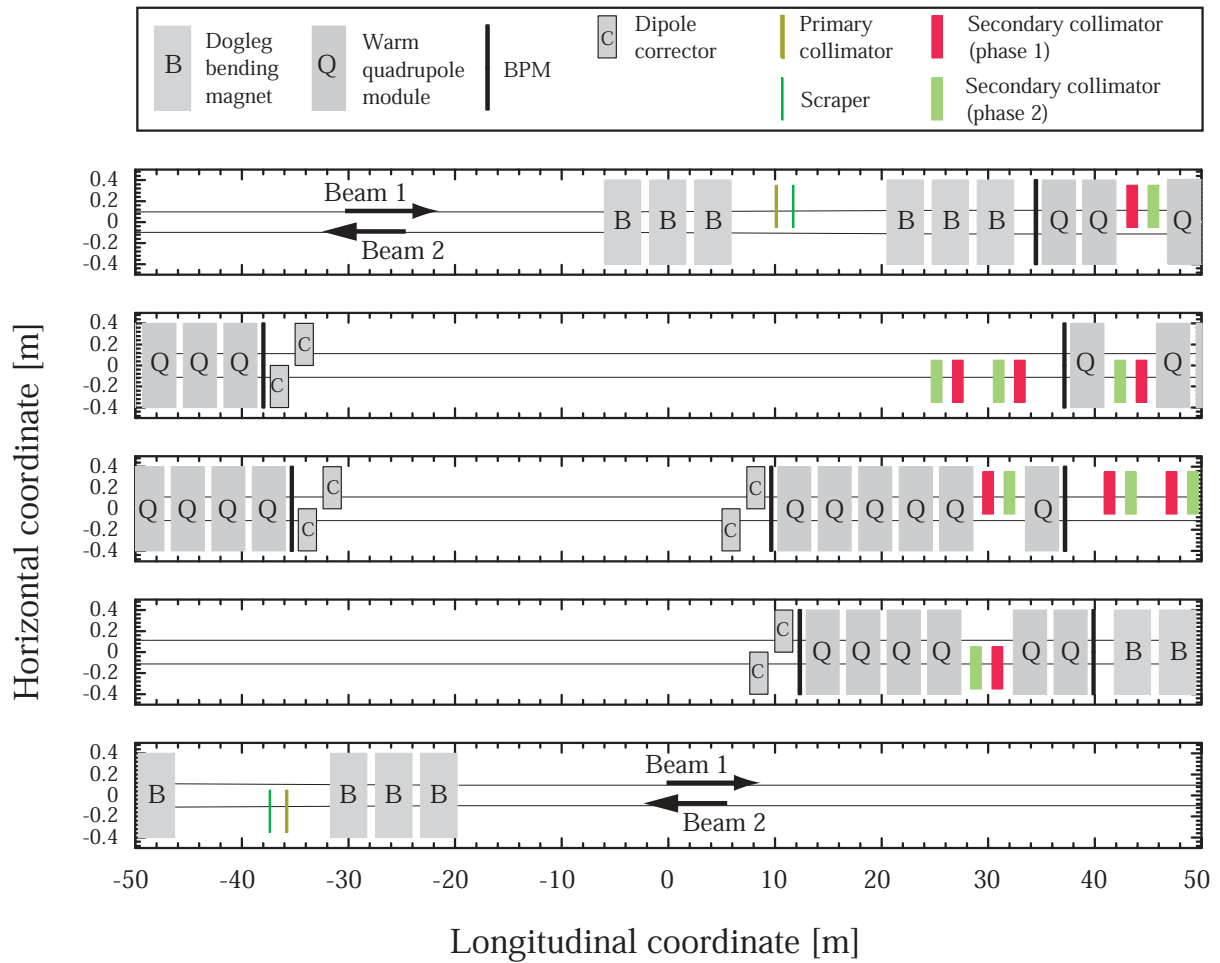

Figure 2: The final layout of the momentum cleaning insertion in IR3. Shown is the active length of components, e.g. a 1.0 m flat-top jaw length instead of the full 2.0 m space reservation for secondary collimators.

shown in Figures 2 and 3. The "active" length of components is shown: For example, a secondary collimator takes a space of 1.0 m (the length of flat top for a Carbon jaw [4]) though a total space of 2.0 m is reserved for the collimator jaw plus tapering plus vacuum tank plus interconnection with quick-handling flanges and flexible bellows.

Both LHC beams are shown with beam 1 running from left to right and from top to bottom. The direction of beam 2 is opposite. It is seen that collimators act on only one beam and have no longitudinal overlap with collimators in the other beam.

### PERFORMANCE

The new layout was confirmed to provide cleaning efficiency comparable to the old layout at a much reduced impedance. An estimate of cleaning inefficiency is given in Figure 4, including hypothetical phase 2 collimators. Further results on cleaning efficiency are discussed in [6]. Impedance of the LHC is reviewed in [2]. The impedance of an LHC collimator prototype will be measured both with beam and in the laboratory with a vibrating wire.

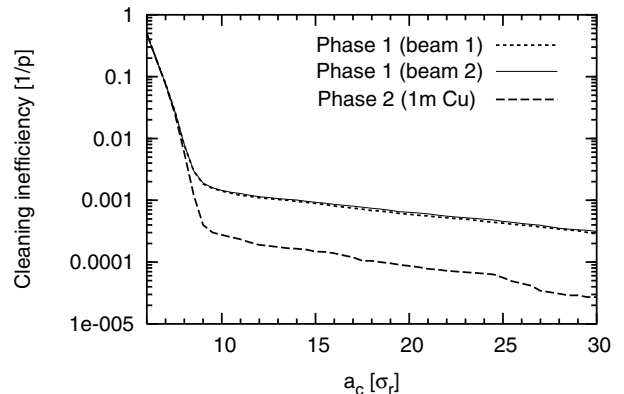

Figure 4: Predicted inefficiencies for betatron cleaning at 7 TeV with 6/7  $\sigma$  settings. Phase 1 and phase 2 performance is shown, assuming 1 m Cu jaws for phase 2.

### INFRASTRUCTURE FOR COLLIMATORS

The infrastructure for collimators was studied and included into the machine integration. About 360 cables with

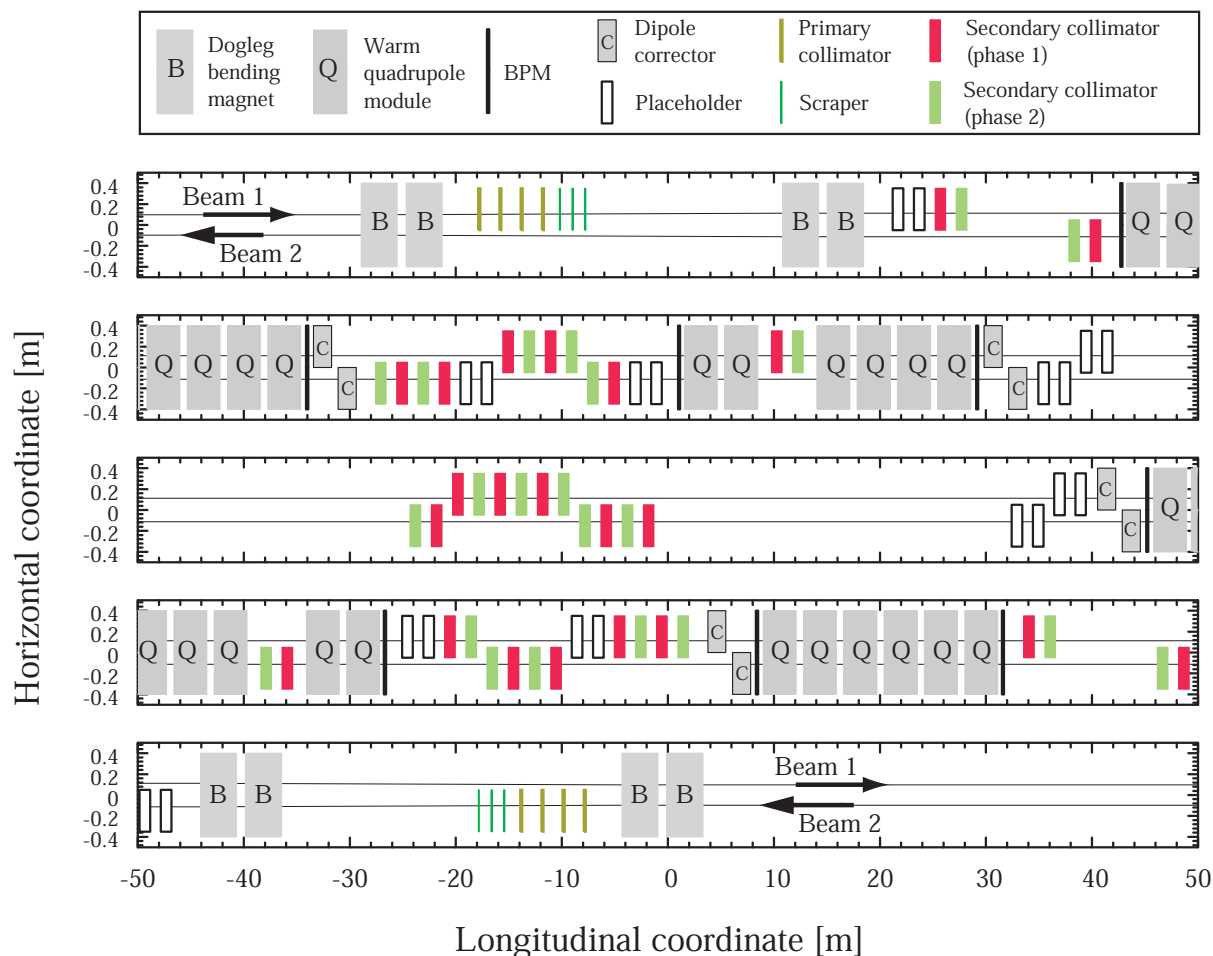

Figure 3: The final layout of the betatron cleaning insertion in IR7. Shown is the active length of components, e.g. a 1.0 m flat-top jaw length instead of the full 2.0 m space reservation for secondary collimators.

a total length of 106 km must be installed for the IR3 collimators during phase 1 and phase 2. In the betatron cleaning insertion IR7 about 1008 cables with a total length of 148 km are required.

The cooling requirements for LHC collimators were specified to provide cooling capacities of 160kW (IR3) and 420kW (IR7) with total flow rates of 36 m<sup>3</sup>/h (IR3) and 96 m<sup>3</sup>/h (IR7). The pressure drop per collimator can be 1.2 bars and a collimator water inlet temperature of 27 °C was accepted. This results in slightly higher peak temperatures on the graphite block and a slightly worse vacuum. However, then the demineralised water circuit (27/42 degrees) can be used for collimator cooling. After a vacuum intervention in a collimator region all collimators in the vented area must be exposed to a bake-out. It is required to empty the cooling water from the collimators beforehand.

## CONCLUSION AND OUTLOOK

New layouts of the LHC cleaning insertions in IR3 and IR7 have been worked out, supporting the phased collimation approach with long collimators and reserve space

allocations. At the same time a thorough optimization of the layout was performed, resulting in various design improvements. The collimator infrastructure has been defined and included into the machine integration. Further studies will aim at including various absorbers (both movable and fixed) into the collimation layout.

## REFERENCES

- [1] R. Assmann et al, "An Improved Collimation System for the LHC". These proceedings.
- [2] The LHC Design Report, Vol. I, The LHC Main Ring, CERN-2004-003 (2004).
- [3] J.B. Jeanneret, "Optics of a two-stage collimation system". CERN-LHC-Project-Report-243 (1998).
- [4] A. Bertarelli et al, "The Mechanical Design for the LHC Collimators". These proceedings.
- [5] The LHC Design Report, Vol. I, Chapter 5, CERN-2004-003 (2004). See also A. Koschik et al, these proceedings.
- [6] R. Assmann et al, "Expected Performance and Beam-Based Optimization of the LHC Collimation System". These proceedings.