

SPOT SCANNING SYSTEM WITH RI BEAM AT HIMAC

K. Sato, K. Hanawa, Y. Iseki, S. Sukenobu, TOSHIBA Corp., Yokohama, Japan
Y. Futami, T. Kanai, M. Kanazawa, A. Kitagawa, T. Murakami, K.Noda,
M. Shinbo, M. Suda, T. Tomitani, NIRS, Chiba, Japan
E. Urakabe, ICR, Kyoto Univ., Uji, Japan

Abstract

We have constructed the spot scanning irradiation system at the secondary beam course in HIMAC. This system has scanning magnet and range sifter. The response time of the range shifter is less than 300 milliseconds. Beam position is measured by a multi-strip parallel plate ionization chamber with strip pitch of 1mm. The calculation of beam center is completed within 1 millisecond in the VME, which is placed independently for horizontal and vertical directions.

1 INTRODUCTION

Radiation therapy with carbon beam was started 1994 at HIMAC [1][2]. In the cancer therapy with heavy ion beam, verification of irradiation volume in the patient body is important. Generally the range is calculated with x-ray CT number using an empirical formula. Though this calculation is carefully checked, there are still several sources of calculation errors.

Using the beam of positron emitter, we can directly check the range in body by detecting annihilation gamma rays. For this purpose, a beam course for secondary beam has been constructed at HIMAC [3]. As a next step, we have started to construct the irradiation system.

There are two irradiation schemes using this system. One is to know the stopping range of the beam with positron cameras. The other one is to know the dose distribution using a PET. Before treatment of radiotherapy, a collimated beam with the pencil shape is irradiated to several points where range evaluation is important in the treatment. We can know the range by detecting the emitted gamma ray with a pair of positron camera. The accuracy is less than 1mm under the limitation that the irradiation for examination has to be less than a few percent of the therapeutic one [4].

If we use ^{11}C beam in the treatment, the irradiation and its verification will be possible by use of the PET. For this purpose, we need to obtain the efficient beam utilization in this irradiation system as high as possible, because the production rate of ^{11}C is less than 1% of the primary beam. Therefore we adopted a spot scanning method to use ^{11}C for the treatment. [5]

In this beam irradiation, the magnetic field of horizontal and vertical scanning magnets are use. And the energy of beam is scanned by range shifter made of acryl

plates. This method simplifies the operation of the accelerator, because it is not necessary to change the beam energy in the accelerator, including the beam transport line. This is particularly suitable for irradiation with a secondary beam, because all parameters of the beam course, including the thickness of the production target, are optimised to the given beam energy.

The beam extraction is stopped during the time of the spot position and the range is scanning. Therefore each device has to move quickly for shortening the total treatment time. The control system has the synchronization of an irradiation beam and the data transfer in the LAN.

2 IRRADIATION SYSTEM

The apparatus of the irradiation system is shown in Fig.1.

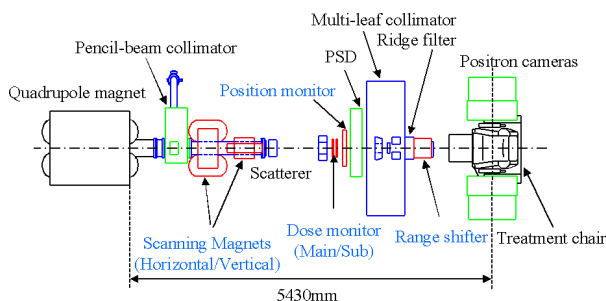

Figure 1: Irradiation system of RI beam at HIMAC

Scanning magnet is a dipole magnet with stacking core. The gap is wide because of the beam size of the secondary beam. To be the length of irradiation system compact, the length of the core is shortening. This system can be used for not only spot scanning method but also wobbler method. The vacuum duct is made by FRP to prevent the eddy current.

Range shifter has 10 various thickness acrylic plates. The minimum thickness is 0.29mm and the maximum is 64mm, and we can use the range from 0mm to 159.79mm by these combinations. To prevent the scattering of the beam, the range shifter is placed just in front of the patient.

There are two kinds of beam monitors in this irradiation system. One is a pair of dose monitor (main and sub). The other one is a beam position monitor. The dose monitor is

a parallel plate type ionization chamber. The position monitor is a multi-strip parallel plate ionization chamber with strip pitch of 1mm [7]. Numbers of the strip are 152 and 112 in the horizontal and vertical monitors, respectively.

Some devices are being used for this system in these others as well. To form sharp lateral dose distribution, multi-leaf collimator with the step width of 2.5mm is installed. The leaves can be rotated. A ridge filter to make the SOBP and a scatterer for wobbler method are also installed. The multi-leaf collimator, the range shifter and the ridge filter can be move to patient along the beam axis. We summarize the parameters of this irradiation system in table 1.

Table 1: Parameters of the irradiation system

System	
Maximum energy	350MeV/u
Distance between the last quadruple and the patient	5430mm
Target volume	100x100x100mm
Scanning magnet	
Core length	300mm
Gap	H; 90mm, V; 160mm
Current	H; -450 to 450A V; -600 to 600A
Rise time (min to max)	H; 20ms, V; 50ms
Range sifter	
Thickness (acrylic plate)	0.29, 0.5, 1, 2, 4, 8, 16, 32, 32, 64mm
Actuator	Air cylinders
Drive time	300ms
Multi-leaf collimator	
Aperture	100x100mm
Number of leaf	L40+R40
Step width	2.5mm
Thickness (Fe)	125mm

As a verification system, we consider a detection of the stopping point of the beam using a pencil beam by a positron camera. A pencil beam is formed by pencil beam collimator arranged upstream of the irradiation system. The position and the shape of the pencil beam are detected by position sensitive detector (PSD). The positron camera consisting of a pair of Anger-type scintillation detectors detects the pair of gamma rays and determines the range of the pencil beam [6].

4 CONTROL SYSTEM

In the irradiation system, there are two groups of controlled devices. One group is concerned with the spot control in the scanning, and the other has slow control. These devices must be controlled surely in the synchrotron facility, where we must use the beam of low

duty factor and relatively large ripple. Considering these things, the control system has following characteristics features;

- 1) Device control performed synchronizing with beam trigger of accelerator.
- 2) The dose detection system, which has high-speed response
- 3) Multi-channel high-speed position calculation, because of the interlock against the position mis-irradiation

A schematic diagram of the control system is shown in Fig.2. This system mainly consists of 2 PCs, 4 VMEs, PLC and a Timing controller. One PC is operation console, which takes a part of man-machine interface, the other is for control, which controls all devices according to the scheduled sequence. VME1, 2 take the part of dose detection, and VME1 control scanning magnets and range shifter as well. VME3 and VME4 are arranged to calculate the position of the beam center in the horizontal and vertical direction, respectively. PLC controls the static devices. Communications between control PC and VME, such as transmission of patten data, which is all the parameters updated for every spot, are performed by LAN. Timing controller is an intelligence device that performs logic processing about all of hardwire signals and sets up timing of trigger. Hardwire signals are followings,

- a) Triggers to VME from timing controller.
- b) Interlock signals to timing controller from all devices.
- c) Preset to each device connected with VME.
- d) Ready signals to timing controller from all devices and VMEs.
- e) Beam gate signal from timing controller to accelerator and flat top gate from accelerator to timing controller.

VME1, 2 consist of CPU, DI, DO, memory area, counter-1 and 2. DI and DO are ports of hardwire signal. Pattern data sent from control PC before irradiation are saved here. Parameters of scanning magnets and range shifter are set VME memories directly.

During the irradiation, dose signals are transmitted from analog circuit in the form of RS422 pulse signal. When the count in counter-1 reach to preset value of pattern data, VME output the signal of the beam inhibit. Since dose data of each spot is preset in counter-1 beforehand, we can realize quickly response within one microsecond. For safety of the treatment, we have counter-2 for interlock, which is operated during counter 1 is not operated. When counter-2 detects the signal during a beam inhibited, beam interlock is outputted immediately to accelerator and shut off the neutron shutter in the beam transport line.

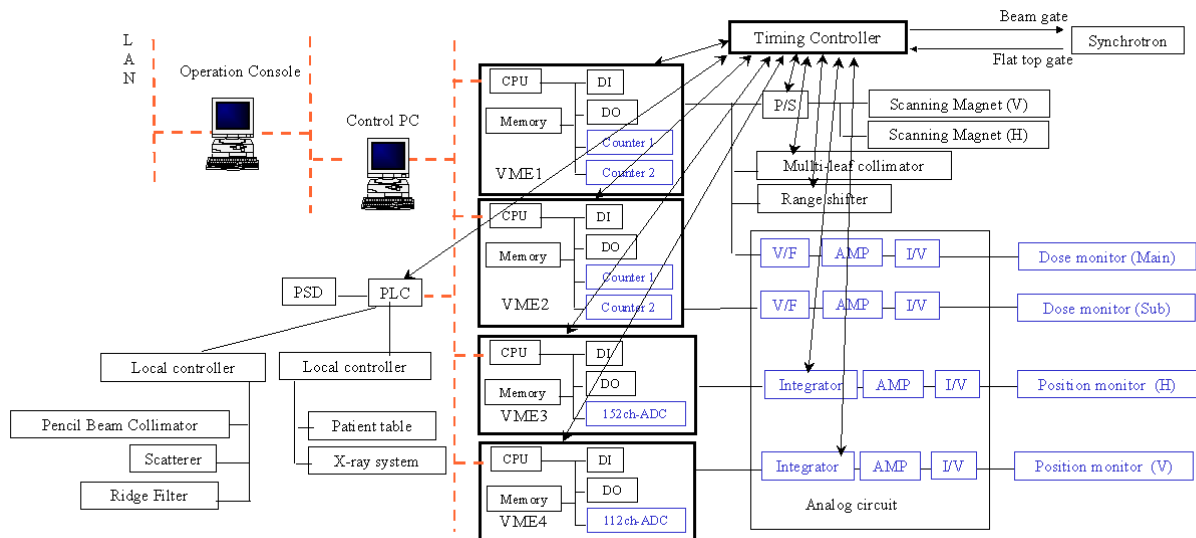

Figure 2; Schematic diagram of the control system

Signals from each strip of position monitor are integrated during the period of each spot. At the same time counter-1 finish counting, multi-channel ADC starts to convert the integrated values to digital signals. If the calculated result of the beam center is different from the pattern data, an error signal is put out and the irradiation of the next spot is not carried out. Since the calculation and the comparison are performed in two VMEs, we can perform the position detection within 1 millisecond without using multiplexer.

As mentioned above, we can realize quickly response of dose and position detection by arranging four VMEs, using LAN and hardware with the timing controller. If communication with the LAN is performed during irradiation, it may obstruct the speed of the calculation in the VME. Therefore we restrict the communication timing between control and each controller to the period the beam is not extracted from the synchrotron. We utilize the signal, which indicates one cycle of accelerator. This signal is received by timing controller and delivered to VME and PLC for the trigger of the communication.

5 SUMMARY

We have constructed the spot scanning irradiation system at the secondary beam course of HIMAC. This system has scanning magnets (horizontal, vertical) and range sifter. The calculation of the beam center is carried out within 1 millisecond by the position monitors, with two VMEs placed independently for horizontal and vertical monitors. In the control system, we have the synchronization between the irradiation beam and the communication in the LAN.

REFERENCES

- [1] Y.Hirao. *et al.*, "Heavy Ion Synchrotron for Medical Use" Nucl. Phys. A538, 541c, 1992
- [2] K.Morita, *et al.*, "Therapy at HIMAC" EPAC, 237-240, 1996
- [3] M.Kanazawa. *et al.*, "Secondary Beam Course for the Medical Use at HIMAC" EPAC-98, 1998
- [4] Y.Iseki. *et al.*, "Numerical Study on Range Measurement System with Positron Camera" The 2nd Japan-Korea Joint Meeting on Medical Physics, 203-206, 1999
- [5] E.Urakabe. *et al.*, "The Spot Scanning Irradiation with 11C Beams" The 2nd Japan-Korea Joint Meeting on Medical Physics, 188-191, 1999
- [6] Y.Iseki. *et al.*, "Positron Camera System for Heavy-Ion Radiotherapy at HIMAC", these proceedings
- [7] E.Urakabe. *et al.*, "Parallel Plate Ionization Chamber for Medical-use Heavy-ion Beams", 11th Symposium on Accelerator Science and Technology