

TUNER SYSTEM SIMULATION AND TESTS FOR THE 201-MHZ MICE CAVITY

L. Somaschini, INFN-Pisa, Pisa, Italy

J. H. Gaynier, R. J. Pasquinelli, D. W. Peterson, R. Schultz, Fermilab, Batavia, IL, USA

Y. Torun, IIT, Chicago, USA

A. J. DeMello, A. R. Lambert, S. Virostek, LBNL, Berkeley, CA, USA

Abstract

The frequency of MICE cavities is controlled by pneumatic tuners as their operation is impervious due to large magnetic fields. The mechanical and RF transfer functions of the tuner were simulated in ANSYS. The first of these tuning systems was assembled and tested at Fermilab. The mechanical response and the RF tuning transfer function have been measured and compared with simulation results. Finally the failure of different actuators has been simulated and tested to predict the operational limits of the tuner.

MICE CAVITY AND TUNER

Each acceleration module (RFCC) of the MICE experiment [1] is composed of four normal-conducting cavities made of copper with a nominal resonant frequency of 201.25 MHz (fig. 1) [2]. The four cavities will be mounted into a vacuum vessel in order to have the same pressure on both sides and avoid deformation of the cavity when pulling vacuum. The cavities will have to work in a high magnetic field that can reach 3T on some points of the cavities surface [3]: a tuning system able to work in such an environment had to be designed. Each cavity will be equipped with a pneumatic system of 6 tuners composed of an actuator and a fork. Each fork, made of stainless steel, will be inside the vacuum vessel and it will stretch and squeeze the cavity when operated by the respective actuator. The actuators will be located outside of the vacuum vessel and will share vacuum with the vessel by means of bellows. All 6 actuators will be connected in parallel and will be controlled by two electronic valves, one responsible for pushing the actuator shaft and the other one for pulling the shaft. The main aim of the tuner will be to compensate for thermal drift of the

cavity and for structural differences between the 4 of them, keeping all the cavities at the same resonant frequency.

A test module with only one cavity has been built and is about to be tested in the MuCool Test Area (MTA) at FNAL [4].

TUNER CONTROLS

Pneumatic System

A control system for the MICE cavity tuner was developed in order to operate the tuner both during test and regular operation in the MTA. Compressed air is provided by a compressor and is filtered to remove any moisture. A relief valve prevents over-pressurization of pneumatic system providing a relief at 120PSI. The incoming air is routed to two proportional valves manufactured by ProportionAir, respectively responsible for the pressurization of the squeeze and stretch circuit of the tuning system. Proportional valves are solenoidal valves with a built in feedback loop. Once they are set to reach a target output pressures, they regulate the airflow to keep the output pressure constant, independently on the input. Three additional electronic pressure gauges by Omega with 4-20 mA current output provide a control over input pressure, stretch and squeeze pressures. All this pneumatic instrumentation is mounted on an aluminum panel and every connection is realized with copper plumbing. Two air lines connect the control panel, placed away from the cavity, to the vacuum vessel. Here a system of manual valves and manifold distributes the air supply to each of the six actuators, allowing for an independent exclusion of each actuator. Every connection on this manifold panel is realized with copper while radiation compatible sealant is used. Manual valves are all made in stainless steel to be radiation compatible and survive operations in the MTA.

Electronic System

The test system is equipped with dedicated control electronics. The measured variables are pressure, resonant frequency of the cavity and movement of actuator shafts. The interface with the user is developed in LabView. Here we have the possibility to set different target pressures, to read digital pressure gauges, to monitor the frequency read by a Network Analyzer and to monitor the movement of each actuator shaft. The PC is directly connected to the NWA and to an ADC by NI to acquire the reading of 6 linear potentiometers used to monitor the movement of each actuator shaft. At the same time the

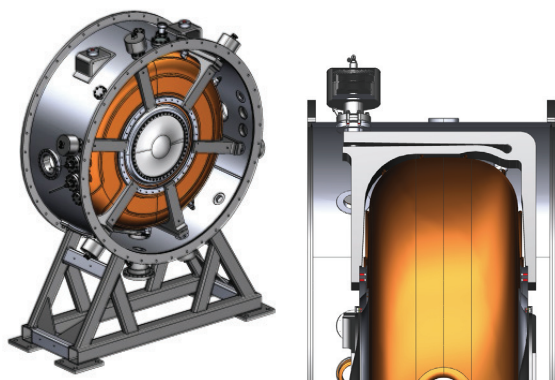

Figure 1: The MTA cavity module and the tuning system.

Content from this work may be used under the terms of the CC BY 3.0 licence (© 2014). Any distribution of this work must maintain attribution to the author(s), title of the work, publisher, and DOI.

LabView code reads and writes registers of a Programmable Logic Controller (PLC). The PLC communicates at 1Hz with the proportional valves and with the digital pressure gauges, providing control and feedback on pressures in the tuning system. The PLC is also equipped with a thermocouple module that can be used if temperature reading has to be included in the tuner control system.

TEST RESULTS

In the following, +/- pressures refer to squeeze/stretch mode. The test started at 0 PSI and then the pressure was raised directly to 100 PSI. From this value it was lowered to -100 PSI in steps of 10 PSI and then raised again to 100 PSI with the same step size. Measurements on the cavity were made both with definitive beryllium windows and with temporary copper windows.

The resulting tuning range, the resonant frequency and Q are shown on table 1. Measured Q proved to be lower than the design one, supposed to be 53000. However it's compatible with the one obtained with the other prototype cavity manufactured by Jefferson Lab. In order to understand the origin of non linearities, frequency was also plotted as a function of fork gap variation. This curve is completely flat, without saturation or hysteresis. The tuning fork can be viewed as a mechanical system whose transfer function connects the actuator shaft position (input) and cavity resonant frequency (output). Since its transfer function is linear, the nonlinearity is not due to a deformation of the tuning fork, but depends on the actuators that are not able to provide enough displacement at high pressures. This result agrees with what was found on bench tests of each actuators [5]. This behavior doesn't represent an obstacle to the correct operation, but simply has to be taken into account in future feedback systems.

Table 1: Tuning Ranges and Q

Variable	Beryllium Windows	Copper Windows
Resonant frequency	200.727 ± 0.009 MHz	201.185 ± 0.001 MHz
Maximum frequency (-100 PSI)	201.033 ± 0.003 MHz	201.475 ± 0.003 MHz
Minimum frequency (100 PSI)	200.329 ± 0.002 MHz	200.801 ± 0.003 MHz
Q	41820 ± 1045	41532 ± 1038

The behaviour of the tuning system can be understood from a plot of frequency as a function of pressure (fig. 2). Data show a remarkable hysteresis cycle: two points at the same pressure can be separated by 20 KHz depending on the fact that pressure is being raised or lowered. Moreover there is a clear tendency to saturation at high negative pressures. These nonlinearities were taken into

account in the following development of the feedback loop for the automated control of the tuner.

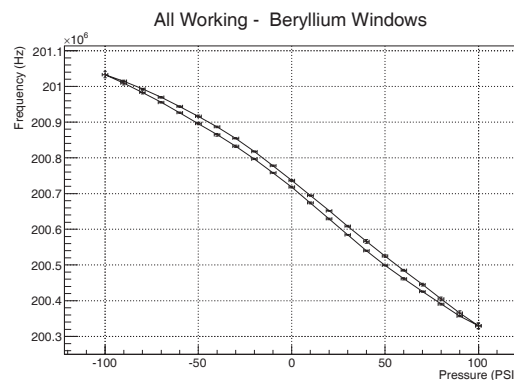

Figure 2: Plot of Frequency vs Pressure.

Comparison with Simulations

The transfer function of the tuning system obtained from these measurement was compared with the one obtained with simulations. Figure 3 shows the measured transfer function (black) and the simulated one (blue). Considerable differences between simulations and real data were found, both in nominal resonant frequency of the cavity and in tuning range. Differences between expected values and measurements are shown in Table 2.

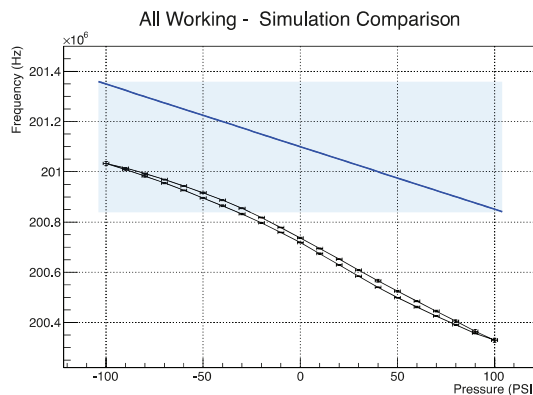

Figure 3: Plot of Deflection vs Pressure for data (black) and simulations (blue).

Table 2: Simulations and Data Comparison

Variable	Measurements	Simulations
Resonant frequency	200.727 ± 0.009 MHz	202.100 MHz
Tuning range	704 ± 4 KHz	500 KHz

Two different simulations were preformed independently, the former using a 2D approach, while the latter with a 3D simulation. Simulations gave results that were comparable to each other but incompatible with

data. The possible cause could lay in the cavity model used, which was deprived of important elements like the four instrumentation ports and the copper cooling lines, resulting in a different nominal frequency and a different elastic module.

the system can only go as high as 3KHz/s. In principle this should be fast enough to give a quick response to thermal drift of the cavity. In any case the power test in the MTA will be a decisive clue.

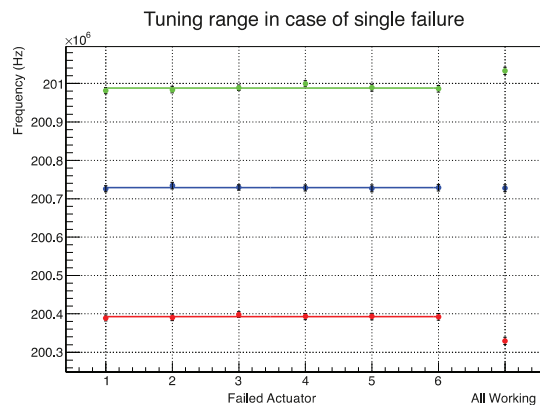

Figure 4: Tuning range as a function of failed actuator (Nominal frequency: blue, Maximum frequency: green, Minimum frequency: red).

IN CASE OF FAILURE

It was decided that it was a good practice to test the response of the system in case of mechanical failure. It's possible that one actuator starts to leak and we had to check if it can be isolated and operation can still continue. Simulations performed in ANSYS workbench revealed that the tuner can be operated even in case of failure (air leak) of one actuator without causing any damage to the cavity. On the contrary, the failure of more than one actuator at a time can result in plastic deformation of the cavity. We shut down one actuator at a time and we repeated the set of measurement performed when all actuator where working. The test revealed that the tuning range is reduced of 100KHz in case of a single failure with respect to the case when all actuators are working (fig. 4).

Moreover the tuning range is almost independent on which actuator is failed.

Another piece of information comes from the study of the actuator shaft movement in case of an actuator failure. The failed actuator receives no air supply, however its shaft undergoes a minimum movement under the action of the other 5 working actuators. This result is in good agreement with mechanical simulations performed in ANSYS (fig. 5).

A cumbersome aspect that emerged from the test is represented by the tuning speed of the system. Proportional valves chosen for the test have a diameter of only 1/8" and they are supposed to control a high volume of air, especially considering that proportional valves need to be placed away from the cavity since they are not radiation compatible. The result is that the tuning speed of

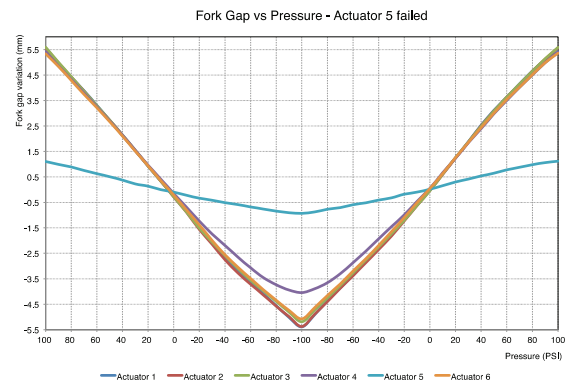

Figure 5: Actuator shaft movement as a function of pressure in case of failure of actuator 5.

CONCLUSION

The tuning system has been assembled on the cavity, and any mechanical issue found during assembly has been solved. Simulations with ANSYS provided information on the operability range of the cavity and on its expected behaviour. The actual test of the tuning system on the cavity revealed that the tuning range is larger than expected but a considerable hysteresis appears at higher deformations. This phenomenon must be considered in future feedback loop. Finally the tuning system proved to be operable even with one actuator out of order.

The next step will involve testing the cavity with RF power and studying if the tuning speed of the system is fast enough to compensate for drifts.

REFERENCES

- [1] Y.Torun and M. Zisman, "Status of the Muon Ionization Cooling Experiment", THPHO18, NAPAC 2014, Pasadena.
- [2] D. Li et al., "The normal conducting RF cavity for the MICE experiment," EPAC'08, Geneva.
- [3] Tianhuan Luo et al., "Progress on the MICE 201 MHz cavity at LBNL", IPAC 2012, New Orleans.
- [4] Y. Torun et al., "Assembly and Testing of the First 201-MHz MICE Cavity at Fermilab", WEPMA16, NAPAC 2014, Pasadena..
- [5] L. Somaschini et al., "Tuner system assembly and test for the 201 MHz MICE cavity", WEPMA03, NAPAC 2014, Pasadena.