

# THE MEDIUM ENERGY BEAM TRANSPORT LINE (MEBT) OF IFMIF/EVEDA LIPAC\*

I. Podadera<sup>†</sup>, J. Calvo, J.M. Carmona, A. Ibarra, D. Iglesias, A. Lara, C. Oliver, F. Toral  
CIEMAT, Madrid, Spain

## Abstract

The IFMIF-EVEDA [1] Linear IFMIF Prototype Accelerator (LIPAc) will be a 9 MeV, 125 mA CW deuteron accelerator which aims to validate the technology that will be used in the future IFMIF accelerator. The acceleration of the beam will be carried out in two stages. An RFQ will increase the energy up to 5 MeV before a Superconducting RF (SRF) linac made of a chain of eight Half Wave Resonators bring the particles to the final energy. Between both stages, a Medium Energy Beam Transport line (MEBT) is in charge of transporting and matching the beam between the RFQ and the SRF. The transverse focusing of the beam is controlled by five quadrupole magnets with integrated steerers, grouped in one triplet and one doublet. Two buncher cavities surrounding the doublet handle the longitudinal dynamics. Two movable collimators are also included to purify the beam optics coming out the RFQ and avoid losses in the SRF. From the inputs of the beam dynamics group, CIEMAT is in charge of designing, manufacturing and integrating all the components of the beamline. In this contribution, the MEBT subsystem will be described and the main objectives and issues for each component will be discussed.

## INTRODUCTION

The MEBT subsystem is responsible of the transport and 6D matching of the RFQ beam into the SRF. In order to minimize the beam losses caused by the strong space charge forces affecting the beam in this area, while keeping the sufficient freedom in beam optics optimization, a very compact scheme based in two sets of quadrupole magnets with steerers and two re-buncher cavities has been proposed by [2]. However this increases the integration challenges that were already noticed by other similar beamlines, e.g. see [3]. CIEMAT is in charge of the design and manufacturing of all the components of the beamline according to the beam dynamics specifications (Fig. 1).

Once the interfaces with RFQ and SRF are removed from the layout, the total length available for MEBT components is roughly 2 m. The aperture of the beamline is 50 mm at the beamline sections, 44 mm at the bunchers area and 40 mm at the interface regions of the RFQ and SRF. The space available being very tight, the following alternatives were chosen (Fig. 2): 1) Steerers to correct

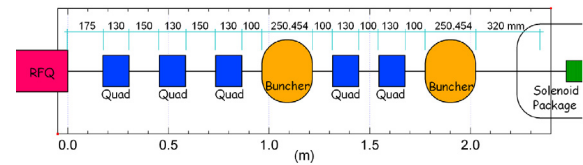

Figure 1: Beam dynamics layout of the MEBT, from [2].

the beam trajectory are placed inside each magnet, 2) The beam position monitors are placed in the middle of four of the five quadrupoles in order to maximize the distance between two beam position monitors, 3) The current transformer is directly attached to the RFQ valve, 4) Scrapers are located between each magnet of the first triplet.

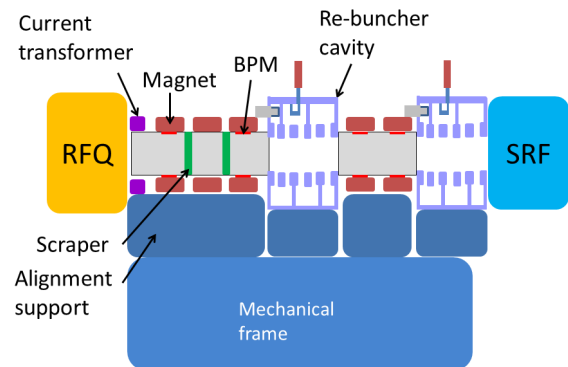

Figure 2: Schematics of the main components of the MEBT.

## MAIN COMPONENTS

### Re-buncher cavities

Two resonant cavities with a maximum  $E_0LT$  of 350 kV and maximum mechanical length of 350 mm are used for longitudinal matching of the RFQ beam with the SRF. The design of this cavity has been very complex due to the stringent beam dynamics requirements and the short length available. After studying several cavity types (pill-box, quarter wave, half wave or spoke resonators) and analyzing different number of gaps, a **five-gap IH resonator** (Fig. 3) has been selected as the reference design [4]. The reference cavity drops the RF power consumption to less than 10 kW, reducing a lot the complexity of the cooling circuit at the stems. In combination with the use of a modern LLRF [5] limits the power necessary even during the transients caused by beam loading.

04 Hadron Accelerators

A08 Linear Accelerators

\* Work partially supported by Spanish Ministry of Science and Innovation under project AIC10-A-000441 and ENE2009-11230.

<sup>†</sup> ivan.podadera@ciemat.es

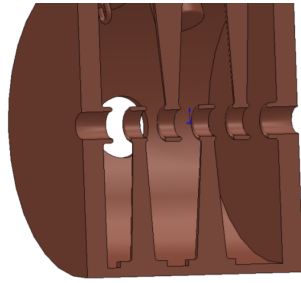

Figure 3: Model of five gap IH re-buncher cavity, for more information see [4].

### Magnets

Compact iron magnets have been designed (Fig. 4) [6] in order to overcome the space difficulties of the MEBT and leave more room to other components. For this reason, they integrate in the same iron yoke the quadrupole and steerer windings, despite of a loss in field quality. Since their short length, MEBT magnets are dominated by the end-coil effects and are slightly saturated at near maximum current. The fringe field that can affect other sensitive components surrounding the magnets (e.g. current transformer or scraper motors) have been also checked. The quadrupoles are designed to operate at a maximum current of 178 A for fields below 25 T/m. Each magnet consumes around 2 kW of electric and cooling power. The aperture of the magnet is 56 mm, designed in order to fit the beam pipe and the BPM's inside the magnets. The vacuum chambers and the BPM will be constructed with non-magnetic stainless steel to avoid perturbations in the magnetic field.

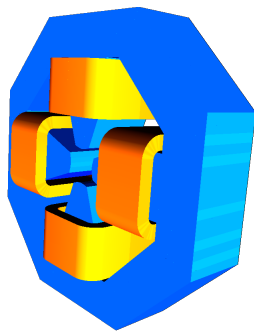

Figure 4: Electromagnetic model of the magnets, for more explanation see [6].

### Scrapers

The beam dynamics simulations [2] showed it was necessary to collimate the beam in order to localize the losses at the MEBT and protect the SRF from the low and high

energy particles out of the MEBT acceptance. The requirements for the design of the scrapers are: 1) they need to be movable in order to optimize the collimation to the real beam conditions, 2) they have to be water cooled in order to handle up to 300 W of deuteron particles, 3) the mechanical length in the beamline direction had to be very short so as to be located in the beamline between each magnet of the triplet. Thermomechanical simulations have been carried out with different surface thermal power distributions as input in the beam-faced wall (Fig. 5) [7] to dimension the cooling circuit of each collimator plate. Several operation modes and type of interacting particle beams have been simulated and a successful design obtained for input to the mechanical design. The location of a thermal sensor for safety purposes was also studied and the sensitivity between the beam-faced wall and the sensor temperature analyzed as detailed in [7].

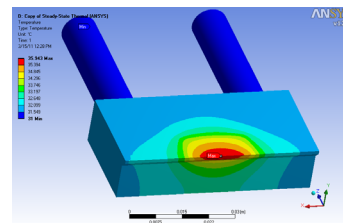

Figure 5: Thermomechanical simulations for the dimensioning of the scrapers, for more explanation see [7].

### Beam diagnostics

The main beam diagnostics are a current transformer (provided by CEA-Saclay) in front of the beamline to measure the transmission of the RFQ, and beam position monitors inside the magnets to measure the beam offset [9]. Alike the SPIRAL2 BPM's [8], they will use the space between the iron poles to locate the four RF feedthroughs of each BPM electrode.

## ASSEMBLY

The MEBT has been designed having in mind the optimization of the integration, alignment and maintenance operations in the accelerator. The complete assembly is supported by an overall frame (Fig. 6) which must fulfil the seismic requirements. In this way the MEBT, once the beamline and auxiliaries are disconnected, can be easily handled by means of the vault crane or using the wheels of the mechanical support. The alignment is guaranteed by the use of laser targets in the most important components: the magnets, the bunchers and the BPM's. The position of the scrapers is fixed to the BPM positions. Each of component is placed over an individual support which provides the fine adjustment of the transverse and longitudinal position. The connection between each section or component of the beamline is done through some welded bellows

which absorb the misalignment and thermal expansions between the parts once they are connected. Bellows will be cooled and protected of beam losses as recommended by LEDA experience [10].

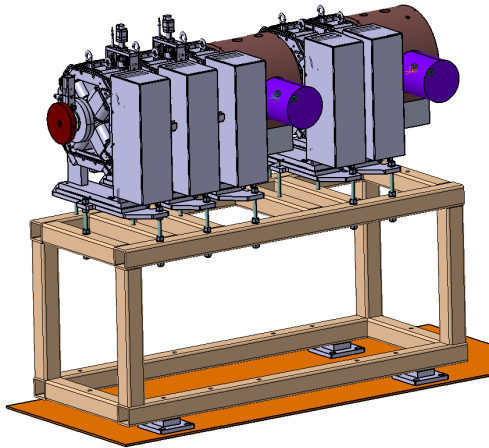

Figure 6: Model of the MEBT.

## AUXILIARIES

### *Vacuum system*

The MEBT interfaces the high vacuum of the RFQ,  $\sim 5 \cdot 10^{-7}$  mbar, and the ultra high vacuum of the superconducting cavities of the SRF,  $\sim 5 \cdot 10^{-8}$  mbar. The pressure drop will be managed by distributed pumping. The pumps will be located in the unique free positions with sufficient space: the re-buncher cavities. Two ports of 100 mm are foreseen in each buncher to maximize the pumping speed available. It is presently being investigated the use of turbomolecular, ionic or cryo pumps in the MEBT environment. RF and static magnetic fields, radiation damage and handling of particle bursts are part of the issues involved with the harsh environment surrounding the pumps.

### *Electric and cooling system*

The electric power required for the magnets power supplies would be around 20 kW, which includes the effect of the long cables (around 30 m) between the power supplies and the magnets at the vault, a margin in voltage for each power supply and the efficiency of the power supplies. The power dissipation of the cables release in the vault a maximum of less than 2 kW which has been taken into account for dimensioning the HVAC system. The cooling system in the vault is divided in two parts: 1) chilled water circuit will be used for the buncher cooling (around 20 kW) in order to minimize the cavity geometry errors, 2) room water circuit for the magnets and the collimators (around 10 kW).

### *Control system*

The MEBT Local Control System (LCS) will provide the interface between the MEBT and the rest of the control sys-

tems of the accelerator. The LCS is governed by a master PLC which controls the vacuum system, the cooling circuit and the sensors of magnets and scrapers. It will interact as well with the power supplies I/O controller (IOC), linked by hard-wired status and shutdown signals. Although it is not yet fully decided, power supplies will be most probably controlled by an Ethernet serial connection to a Linux PC with EPICS, which is used by all the accelerator. Beam diagnostics are not included as they have independent IOC's and are not considered as part of the MEBT LCS.

## CONCLUSIONS AND OUTLOOK

A feasible design for the MEBT has been found and the detailed design is well advanced. For some components the design is almost ready for manufacturing. Because of the complexity of the design, prototypes of some of the components are being constructed in order to test each system individually and validate the assembly before launching the manufacturing of the series.

## ACKNOWLEDGMENTS

We would like to thank the help from the LIPAC EU-HT and especially the fruitful discussions with P-Y. Beauvais about the design of the assembly, the feedback from the Beam Dynamics team (N. Chauvin and P. Nghiem) and the interaction with RFQ, SRF and beam diagnostics teams. We also want to acknowledge the important suggestions from D. Schneider which come from the experience of the LEDA operation. Last but not least, a warmful thank to ANTEC and AVS companies for the careful and brilliant design of magnets and scrapers respectively and for the fruitful exchanges and feedback which were required due to the complexity of the design.

## REFERENCES

- [1] A. Mosnier et al., proceedings of IPAC10, MOPEC056, p. 588, Kyoto, Japan (2010).
- [2] P.A.P. Nghiem et al., Nucl. Instrum. Meth. A, doi:10.1016/j.nima.2011.06.102.
- [3] D. Oshatz et al., TPAH152, PAC01, Chicago, USA, 2001.
- [4] A. Lara et al., MOPC047, these proceedings.
- [5] A. Salom et al., MOPC160, these proceedings.
- [6] C. Oliver et al., WEPO014, these proceedings.
- [7] D. Iglesias et al., THPS059, these proceedings.
- [8] R. Ferdinand, SPIRAL 2 week, Caen, 2009.
- [9] I. Podadera et al., TUPD11, DIPAC11, Hamburg, Germany, 2011.
- [10] "MEBT PDR review committee recommendations", internal note, 2010.