

DESIGN OF A COMPACT LIGHT SOURCE ACCELERATOR FACILITY AT IUAC, DELHI

S. Ghosh, B. K. Sahu, A. Rai, G. K. Chaudhari, P. Patra, J. Karmakar, A. Pandey, N. Kumar, R. K. Bhandari, D. Kanjilal, Inter University Accelerator Centre, New Delhi, India
 J. Urakawa, A. Aryshev, High Energy Accelerator Research Organization, KEK, Tsukuba, Japan
 V. Naik, A. Roy, Variable Energy Cyclotron Center, Kolkata, India
 A. Deshpande, T. Dixit, Society for Applied Microwave Electronics Engineering & Research, Mumbai, India

Abstract

There is a growing demand for a high brightness light source with short pulse length among the researchers in the field of physical, chemical, biological and medical sciences in India. To cater to the experimental needs of multidisciplinary sciences, a project to develop a compact Light Source has been initiated at Inter University Accelerator Centre (IUAC). In the first phase of the project, pre-bunched electron beam of ~ 7 MeV energy will be generated by a photocathode RF gun and coherent THz radiation will be produced by a short undulator magnet. In the next phase, the energy of the electron beam will be increased up to 40 MeV by a pair of superconducting niobium resonators. The coherent IR radiation will be produced by using an undulator magnet (conventional method) and X-rays by Inverse Compton Scattering. To increase the average brightness of the electromagnetic radiation, fabrication of superconducting RF gun is going to be started in a parallel development. In this paper, the design of the accelerator system and the plan of producing THz radiation will be discussed.

INTRODUCTION

Inter University Accelerator Centre (IUAC), New Delhi, is a national accelerator facility equipped with many ion accelerators notably a 15UD Pelletron accelerator, a superconducting Linac booster [1], a 1.7 MV Pelletron and various low energy ion beam facilities. These accelerators are used to carry out research in the field of nuclear physics, materials science and radiation biology. Recently, to address the growing needs of the researchers from multidisciplinary fields like biological, chemical, medical and physical sciences, a project to develop a Free Electron Laser (FEL) facility named as Delhi Light Source (DLS) has been initiated at IUAC.

The development of the DLS project is being started with a room temperature (RT) photocathode RF electron gun which will produce a high quality electron beam of energy ~ 7 MeV. The beam will be then injected into a short undulator magnet to produce radiation in the THz range.

Simultaneously, to operate the RF gun in cw or quasi-cw mode, development of the superconducting (SC) RF photocathode electron gun is being explored. The SC RF gun will be either a three and half-cell niobium resonator similar to the structure being used at Rossendorf, Dresden

[2] or a Quarter Wave Resonator (QWR) similar to the design adopted by Brookhaven National Laboratory (BNL) [3]. Experience of IUAC in the fields of fabricating niobium resonators, cryostats and cryogenic systems will be useful in this development. The energy obtained from the 3.5 cell elliptical structure is estimated to be ~ 10 MeV. This beam will then be injected into an undulator magnet to produce THz radiation. However, if the QWR structure is adopted as RF gun, then the energy gain from the gun will be only a few MeV, so another 5 cell TESLA type SC resonator will be required to increase the energy upto ~ 10 MeV. Both the options of SC RF gun is shown in Fig. 1.

In the next phase of the development, two 9 cell TESLA type cavities will be installed to boost the energy from ~ 7 MeV (from RT RF gun) or 10 MeV (from SC RF gun) to ~ 40 MeV. This beam will be switched to three different beam lines. One beam line will be dedicated to produce infrared (IR) radiation with the help of a long undulator magnet. The second beam line will be for X-rays produced by the technique of Inverse Compton Scattering whereas the third one will be dedicated for experiments with THz/Far-IR and/or with 40 MeV electron beam. The layout of the complete project plan is shown in Fig. 1.

THE PROJECT – DELHI LIGHT SOURCE (DLS)

The compact light source project will make IUAC a unique national facility with the potential to deliver THz, IR, X-rays and electron beams as well as the energetic ion beams from different ion accelerators. The schematic of the layout of the Delhi Light Source is shown in Fig. 1. The project will be executed in three phases, namely:

- (a) Phase-I: to produce THz radiation from a RT photocathode RF gun.
- (b) Phase-II: to produce THz radiation from the SC photocathode RF gun
- (c) Phase-III: to increase the energy of the electron beam up to 40 MeV with the help of TESLA type resonators and to use this beam to produce THz, IR and X-rays.

The different phases are described in detail in the following sections:

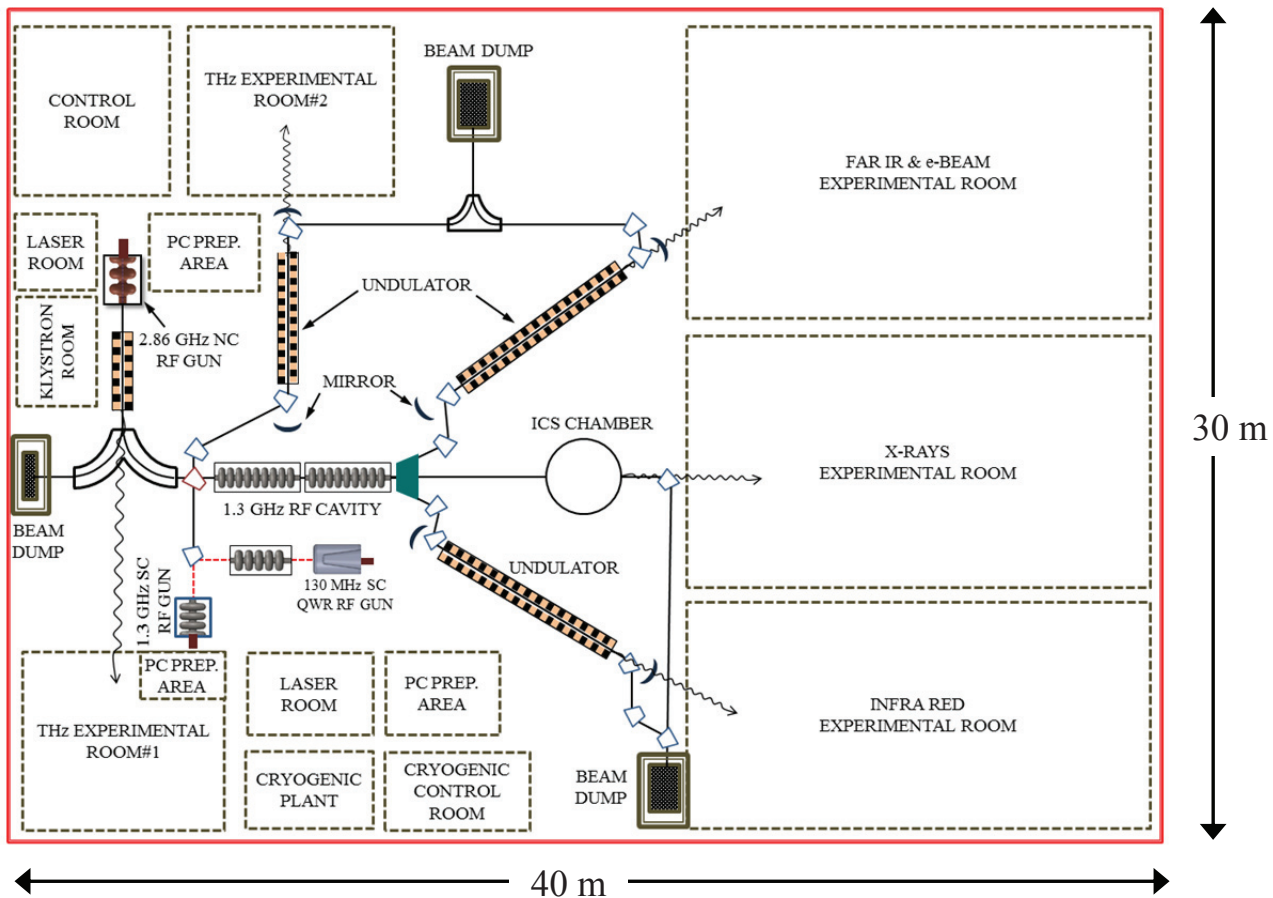

Figure 1: The complete layout plan of the Delhi Light Source (DLS).

Phase-I: To Produce THz Radiation from Room Temperature Photocathode RF Gun

The intense and ultrashort THz radiation can be produced by injecting pre-bunched [4] electron beam with FWHM of a few hundred femto-seconds (fs) into a short undulator magnet of a length of approximately ~ 700 mm. The wavelength of the electromagnetic radiation emitted from the undulator magnet depends on the electron beam energy and the undulator parameters. The equation relating to these parameters is as follows:

$$\lambda_R = \frac{\lambda_u}{2\gamma^2} \left[1 + \frac{K^2}{2} \right]$$

where

λ_R = Radiation wavelength

K = undulator parameter = $\frac{eB_u\lambda_u}{2\pi mc} = 93.4B_u(T)\lambda_u(m)$

λ_u = undulator wavelength

γ = E/E_0 , ratio of electron energy to its rest mass energy in MeV

e = electronic charge (C)

B_u = Magnetic field of the undulator (T)

m = mass of electron (kg)

c = velocity of light (m/sec)

In the case of pre-bunched FEL, if the separation between the successive micro-bunches of the electron beam matches with the desired λ_R , then the emitted radiation from the micro-bunches passing through the undulator adds up in phase and the radiation power increases quickly.

The micro-bunching of the electrons takes place at the photocathode by the laser pulse stacking to generate a train of laser pulses ('comb' beam [4]) with a pulse repetition rate at THz frequency. The train of laser pulses is generated from a single laser pulse with the help of polarizing beam splitters (PBS), half wave plates and optical delay lines. The time spacing between the two successive pulses can be adjusted by carefully varying the path of the optical delay line. The variation of the time spacing ranges from ~ 333 fs to 3.3 ps (from $f = 3$ THz, $\lambda = 100 \mu m$ to $f = 0.3$ THz, $\lambda = 1$ mm). So by varying the time spacing between the laser pulses, the separation between the electron micro-bunches can be varied and a range of electromagnetic radiation will be produced when those microbunches will pass through a short undulator. However, due to space charge effect and relatively slow response time of production of electron from Cs_2Te photocathode, it is difficult to reduce the bunch length of the electron beam below ~ 300 fs.

Copyright © 2014 CC-BY-3.0 and by the respective authors

Table 1: Parameter of the Ti:Sa Laser System

Wavelength	800 nm
Reference frequency	130 MHz
Oscillator frequency	130 MHz
Pulse duration	~ 40 fs
Repetition rate	10 Hz
Energy per pulse	~ 25 mJ

Table 2: Design Parameters of the Room Temperature (RT) Photocathode RF Gun

Electron energy (MeV)	7
Charge / micro-Pulse (pC)	100
E-beam bunch length (fs)	300
No. of micro-bunches (300fs each)	16
Frequency of micro-bunch trains (Hz)	10
Peak current (A)	333
Peak beam power (GW)	2.3
Average beam current (nA)	16
Average beam power (W)	0.112

The layout of the room temperature RF gun and the THz experimental room #1 is shown in Fig. 1. It has been decided, that DLS will have 2.6 cell copper resonator with a design similar to that of BNL and KEK [5]. This will be a S-band structure with resonance frequency of 2860 MHz. The energy obtained from 2.6 cell resonator is estimated to be ~ 7 MeV and RF pulse power requirement (peak) is calculated to be 18 MW (maximum).

The frequency of the copper resonator to be used as the RF gun is chosen to be 2860 MHz which is just a few MHz more than the commonly used frequency of 2856 MHz. The reason behind choosing 2860 MHz is that it is the 22nd harmonic of the reference frequency of 130 MHz as the frequencies of the SC cavities are chosen at 1300 MHz (3.5 cell TESLA type cavity) or 130 MHz (QWR).

A Cs₂Te photocathode inserted into the copper resonator would be used for the production of the electron beam. The development of the vacuum chamber to produce Cs₂Te photocathode, its vacuum transport system and load lock mechanism are being undertaken. With the remarkable success of GaN photocathode [6] and with its strong possibility for commercial availability, Cs₂Te may be substituted by GaN as photocathode material in future. To produce electrons from photocathode, a Ti:Sa femto-second (fs) laser system will be used. The laser parameters are given in Table 1.

The calculated design parameters of the room temperature RF gun and the THz radiation produced from the electron beam are given in Table 2 and 3.

Table 3: Expected Parameters of the 2.0 THz Radiation Emitted from the Electron Beam Produced by RT RF Gun

Radiation wavelength (μm)	150
K-parameter	0.8
Undulator period (cm)	3.4
RMS strength (T)	0.25
No. of periods (N) with 1m undulator	30
Peak radiation power (MW)	15
Average radiation power (mW)	0.75
Peak no. of photons /sec	10^{28}
Average no. of photons /sec	10^{17}

Phase-II: To Produce THz Radiation from Superconducting Photocathode RF Gun

The second phase of the project will be started after witnessing a stable progress of Phase-I. In Phase-II, two possibilities are currently being explored. The first option is to develop a 3.5 cell 1.3 GHz niobium resonator [2] along with the provisions of (a) an independent tuning mechanism of gun and accelerating cells, (b) movement of the photocathode plug to optimise electron beam properties and (c) to generate a magnetic mode (TE) inside the cavity, predominantly around the last accelerating cell to reduce the transverse emittance of the beam. In addition, a resonant superconducting choke filter to prevent leakage of RF power from the cavity as well as the Higher Order Modes (HOM) and input couplers are to be designed.

In the second option, a niobium quarter wave resonator of 130 MHz will be developed and installed in the beam line (Fig. 1). This QWR would be similar to the existing QWRs for the heavy ion linac at IUAC [1]. The details of photocathode insertion mechanism inside the central conductor, set up for injecting the laser beam on the photocathode etc. are being worked out. The expected parameters of both the superconducting RF guns (1.3 GHz, 3.5 cell and 130 MHz QWR) are given in Table 4.

With the superconducting cavity, either with elliptical resonator or QWR, the THz radiation with the pre-bunched electron beam ('comb beam', similar to the case of room temperature RF gun) can be obtained in THz Experimental room#2 (Fig. 1). However, since this electron beam will have less average current, the total power of THz radiation will be low. So when quasi-cw electron beam will be produced from the superconducting RF gun, the beam will be injected into longer undulator magnet with optical cavity to produce THz radiation of much higher average power (Fig. 1).

Table 4: Design Parameters for the Superconducting Photocathode RF Gun

Frequency (MHz)	1300	130	
Type of operation	High Charge	High Current	
Electron energy (MeV)	10	10	2
Max bunch charge (nC)	1	0.05	4
Pulse duration (ps)	20	5	220
Bunch repetition (MHz)	1	39	13
Peak current (A)	50	10	18
Average current (mA)	1	2	52
Norm. transverse emittance (mm-mrad)	3	1	3
Photocathode material	Cs ₂ Te/ GaN	Cs ₂ Te/ CsK ₂ Sb	Cs ₂ Te/ GaN
Driving laser wavelength (nm)	266	266	266
Operating temp (K)	2	2	4.2

Phase-III: To Increase the Energy of the Electron Beam up to 40 MeV with the help of TESLA Type Resonators and to use this Beam to Produce Far-IR, IR and X-rays

The high quality electron beam from the room temperature RF gun and the SC RF gun can be injected into a couple of 9 cell TESLA type 1.3 GHz SC resonators which will further increase the energy of the electron beam from 7/10 MeV to ~ 40 MeV (Fig. 1). Frontline research experiments can then be carried out in three different beam lines. In the first beam line, far-IR radiation can be produced by long undulator magnet and experiments can be done with this radiation as well as with 40 MeV electron beam. In the second beam line, X-rays will be generated by the technique of Inverse Compton Scattering (ICS) by striking the electron beam with another laser [7]. In the third beam line, infrared radiation produced from the electron beam with the help of long undulator magnet, will be used for other set of experiments. The accelerator, the experimental facilities, the laser, the klystron, the control room and the shielded beam dumps will be accommodated in a hall of 40m x 30m (Fig. 1).

PRESENT STATUS OF THE PROJECT

Presently the phase-I of the project that aims at development of a RT RF gun to produce high quality electron beam of energy ~7 MeV has been started. For this, the fabrication of the copper resonator is being started with the help of KEK, Japan. The beam-line optics

design is going on and will be completed soon. The parameter finalization for the Klystron and the laser system is in progress and the purchase order for both the items will be placed shortly. The manufacturing and/or procurement of different beam diagnostic elements will be started once the beam optics design is finalised. Some preliminary work on the preparation procedure of the photocathode with the design of the preparation chamber has been started. The infrastructure for installing the RT RF gun is being developed and will be finished by the end of 2014. The low power tests of the RF gun are planned to be done by the end of 2014 followed by the high power tests in next 6 months.

To develop the SC RF gun, exploratory studies of SC photocathode RF gun based on Rossendorf type and 130 MHz QWR type based on BNL design are being carried out.

ACKNOWLEDGEMENT

The authors sincerely acknowledge the help and suggestions received from Prof. Ilan Ben-Zvi and Dr. Triveni Rao of Brookhaven National Laboratory, USA. The help received from Prof. S. Fukuda and Prof. Terunuma of KEK, Japan is also highly appreciated.

REFERENCES

- [1] S. Ghosh et. al., Physical Review Special Topic – Accelerator and Beams, 12.040101 (2009).
- [2] A. Arnold et. al. Nucl. Inst. Meth. A577, 2007, p. 440.
- [3] J. W. Lewellen, Proc. of ERL09, Ithaca, New York, p. 24.
- [4] S. Liu and J. Urakawa, Proc. of Free Electron Laser 2011, Shanghai, China, p 92-95.
- [5] X. J. Wang et. al., Nucl. Inst. Meth. A356, 1995, p. 159.
- [6] O. Siegmund et al. Nucl. Inst. Meth. A567, 2006, p. 89.
- [7] J. Urakawa, Nucl. Inst. Meth. A637, 2011, p. 547.