

A GAAS PHOTOEMISSION DC GUN FOR CAEP HIGH-AVERAGE-POWER THz FEL*

Hanbin Wang[#], Kai Li, Ming Li, Dai Wu, Dexin Xiao, Xingfan Yang
Institute of Applied Electronics, CAEP, China.

Abstract

FEL-THz plays an important role in THz science and technology research, for high power output and tunable wavelength, which is indispensable to material, biology, medical research. Now, the construction is underway at China Academy of Engineering Physics (CAEP) on high-average-power FEL THz source, and the demonstration of stable, reliable, high brightness, high power electron source operation is one of key issues. The components of the system were constructed and the performance tests are still on. The lifetime of the Negative Electron Affinity (NEA) surface is about 40 hours, which is limited mainly by vacuum. Up to now, the gun can supply 5mA beam current and has been employed for preliminary experiments. In this paper, the design considerations and present status are given.

INTRODUCTION

FEL-THz source is a strong candidate among THz sources in THz application researches, and now a high-average-power FEL-THz source is under construction in CAEP. The key component of the facility is a high average current, low emittance electron source, which should deliver about 100pC/bunch (the average current of 5mA). To fulfil the requirements, the DC gun becomes a leading choice for better technical maturity[1]. Since the gun can offer excellent vacuum, we use a NEA GaAs photocathode, which has a relatively high quantum efficiency (QE) and practical operating wavelength.

The construction of a DC gun is still careful to do, despite its technical maturity and there are two items to consider. One is how to achieve the extra-high vacuum, NEA GaAs is chemically reactive and is degraded by a small fraction of H₂O or CO₂. Photo-cathode's QE can be degraded by ion back bombardment, independent of the gas species forming the ion. The other is how to realize high voltage stable operation, the field emission is a principal challenge[2], which arises from the cathode electrode and its support structure may result in voltage breakdown across the cathode-anode gap, or a punch-through failure of the insulator holding off the cathode potential, and directly affects operation.

The very successful Jlab IR FEL operates based on a photocathode dc gun[3]. The gun design started as a 500 kV gun with a peak electric field of 10 MV/m at the surface of the cathode in the beginning of 1990's[4]. Due to field emission from the electrode structures encountered during the 1kW IR Demo's commissioning,

the gun has been modified to a lower gradient at the cathode achieved by lowering the operating voltage to 320kV and by increasing the cathode-anode gap (6 MV/m at 500 kV)[5]. The 500kV operation is realized until 2011[6]. So, it should be envisioned that the high voltage operation must circumvent many obstacles. We consult the experiences from other lab and ours, and the design incorporates some features of the existing DC gun. In the following sections, the component solutions adopted and the CAEP DC gun status are given.

DESIGN OF CAEP DC GUN

High QE cathode must be prepared and transferred under vacuum. The existing photoemission DC guns can be classified into two types; one prepares cathodes in situ in the electron guns, the other transfers cathodes under vacuum from a separate preparation chamber by a load-lock.

As Fig. 1 shows, the CAEP DC gun adopts a load-lock design too, which consists of three components (photocathode load-lock system, main gun chamber and mode lock laser). The following describes a design on the major points of interest about each component.

PHOTOCATHODE LOAD LOCK SYSTEM

The photocathode load lock system includes three chambers as shown in Fig. 1, where the function is realized of cathode puck introduction, preparation and storage.

The beginning part is an introduction chamber, and the primary function is to introduce pucks and store them for subsequent processing. The first processing is atomic hydrogen cleaning, which provides a means to clean exotic photocathode materials for which wet chemistry techniques are incapable. A KYKY F700 turbo-pump is used during atomic hydrogen cleaning where typical values for temperature and pressure near the sample are 200 C and 2E-3 Pa respectively. During the process, a ceramic heater is used to raise sample temperature for atomic hydrogen cleaning.

The middle part is a preparation chamber, where the heating and activation processing are completed. A magnet manipulator transfers a puck from the introduction chamber to the preparation chamber after atomic hydrogen cleaning process. Same to the heating process in the introduction chamber, a ceramic heater is used to heat the wafer to about 450 C at a ramp rate up and down of 1 C per second, and the ramp down control is aided by an active cooler. The preparation chamber is a stainless steel chamber with eighteen ports placed around the circumference, which contains all of the components to produce NEA photocathodes: a channel cesiator, a NF₃ or

*Work supported by the ministry of science and technology
#wanghanbin@caep.cn

O₂ oxidizer, a ring anode, an optical window for light, 100 l/s sputter ion pump, CapaciTorr D3500 SAES NEG. In addition, a residual gas analyzer (RGA) and an extractor gauge used for vacuum diagnostics.

The last part is a storage chamber, which allows us to activate several wafers during an accelerator maintenance day and store them for future use. The three chambers are separated by a 2.5-inch VAT ultra high vacuum metal sealed valve.

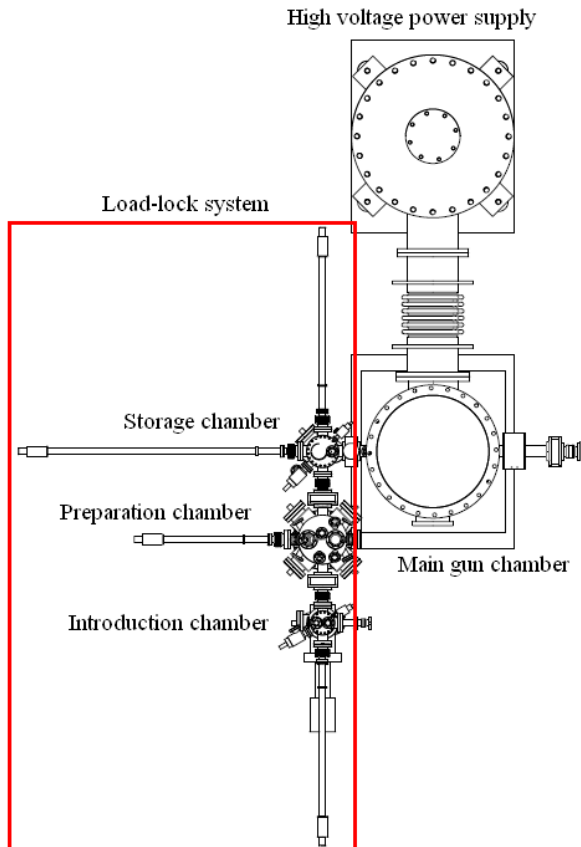

Figure 1: Layout of the photoemission DC gun.

MAIN GUN CHAMBER

The main gun chamber consists of ceramic insulator, stainless steel chamber and electrodes, which provides superb vacuum for NEA photocathode and isolated insulation between high voltage and earth potential.

Design of Extreme-high-vacuum

The operation of high average power FEL-THz requires higher QE photocathodes, but to date they are readily poisoned by small quantities of chemically active gases such as water, oxygen and carbon dioxide[7]. Relatively inert gases such as hydrogen, methane, nitrogen and carbon monoxide have small to negligible poisoning effects on these cathodes, but they can be ionized by electrons traversing cathode-anode gap, and are accelerated back to the photocathode to cause QE degradation. So we must take measures to achieve

extreme high vacuum. The vacuum pump scheme is with triple-ion-pump and non-evaporable getter (NEG) pump, which are well suited for pumping CO, CO₂ and greatly enhanced the pumping speed for hydrogen[8], the dominant gas species in the extreme high vacuum systems.

The original pumping system of the gun chamber was designed to have a 800l/s triple ion pump and three 1300l/s NEG pump[9]. The total pressure were monitored by a B-A ion gauge, and the vacuum pressure falls down to 6.0E-9 Pa after bake-out of the gun chamber at 200°C for about 96 hours and ramps up to 1.2E-8Pa during 5mA operation. In this case, the cathode operation lifetime is so short to make the facility use efficiency too low.

To get longer operation lifetime, we make some improvements on the basis of practice of our lab and experience of other laboratories.

- The internal walls of the chamber were vacuum fired to 500C to decrease the hydrogen load in the bulk material.
- All viton-seal valves used in the gun chamber were replaced by metal-seal to be baked at higher temperature ($\leq 300^{\circ}\text{C}$).
- The total pumping speed of NEG pumps was reinforced up to 20,000l/s and a 100l/s ion pump was redeployed for inert gas pumping.

Design of High Voltage Parts

The DC gun's high voltage parts include two ceramic insulators, potential dividers, cathode electrodes and their support structure, as shown in Fig. 2. The principal technology challenge is still the field emission from the cathode electrode and its support structure.

The DC gun insulator works in high voltage, high vacuum and high pressure. The voltage holdoff capability of a high voltage ceramic insulator in vacuum is poor compared to that of the ceramic material or the vacuum itself. Field emission originating at the triple junction of ceramic-metal-vacuum is a well-understood cause of internal surface flash-over, and is controlled by reducing the field on the junction with electrostatic shields. The external ceramic surface is usually corrugated to inhibit flashover. But it is unavoidable that the inner surface of ceramic intercepts electrons field-emitted from support tube or meso-potential electrode. Aiming at former problem, the ceramic adopts charge-dissipative type, which provides some surface conduction to bleed off accumulated surface charge and so as to suppress the surface flashover.

The field uniformity can improve the stability and reliability of the DC gun on the surface of a ceramic insulator. We adopted shielding rings which distribution is non-proportional spacing to obtain comparatively equal electric field on the insulator surface, and the potential between rings is controlled by a high-Ohmic divider.

During design of electrodes, the choice of material is a very important ingredient for high potential gradient operation of DC gun. In the foregone experiments, the titanium alloy exhibits better high voltage performance

than stainless steel[10], and the design adopts titanium alloy to make electrodes and tee support. In a pierce gun, the peak field on the electrode is two to three times higher than the field on the cathode, so we adopt flat cathode surface, which produce a high degree of electric field uniformity over the emitting area and have lower peak electric field than pierce type cathode electrode ensuring the emitting field.

To lower the peak electric field of the support tube, a meso-potential electrode is adopted in DC gun, and the peak electric field on the support tube is just 70 percent of field strength without meso-potential electrode, which can effectively decrease the field-emitted currents in the high voltage operation.

The high voltage is supplied by a nominal voltage of 400kV and the maximum current of 10mA. The high voltage power supply is located in a pressure vessel holding 0.6MPa of SF₆, which is connected with the insulator pressure vessel by bellows.

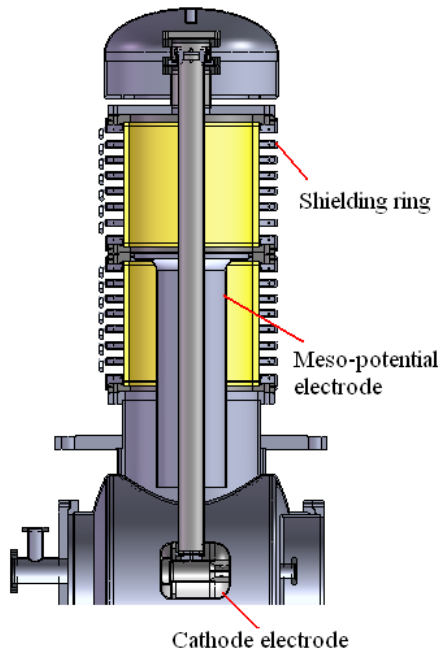

Figure 2: Scheme of the gun high voltage parts.

MODE-LOCK LASER

As drive laser for NEA photocathode, a frequency doubled, mode-locked Nd:YAG laser (GKML-532) is used[11]. The laser generates pulses at a maximum repetition rate of 54.17 MHz in CW mode and up to 3 W of SHG power (on cathode surface) at 532 nm. A maximum current of 5mA can be obtained still, even if the QE of photocathode is low to 0.4%.

PRELIMINARY RESULTS AND WORK SCHEDULE

The new gun is debugging based on the forementioned design thoughts, and the vacuum performance steps up

more than an order of magnitude as compared with original design, new design is about 7E-9Pa while the original 1.5E-7Pa, being pumped only by ion pump.

Proof experiments have been done on the original gun. The gun can operate at 320kV stably, but the current of 5mA (10 ms-long pulses at 10 Hz) just continue about 5 hours for poor vacuum of 1.2E-8Pa, when it is a precondition that maximum power of the drive laser is constant. At the same time, the QE measurements show lifetime (Cs-O activation) is about 40 hours in preparation chamber, where it is measured intermittently, i.e. so-called dark-lifetime. The term lifetime is defined as the time that QE fell to 1/e from the initial value takes, and the QE change with time is shown in Fig. 3. Compared with the results of dark-lifetime from other labs[2], we must realize the space for improvement is so large still and there are many things to do.

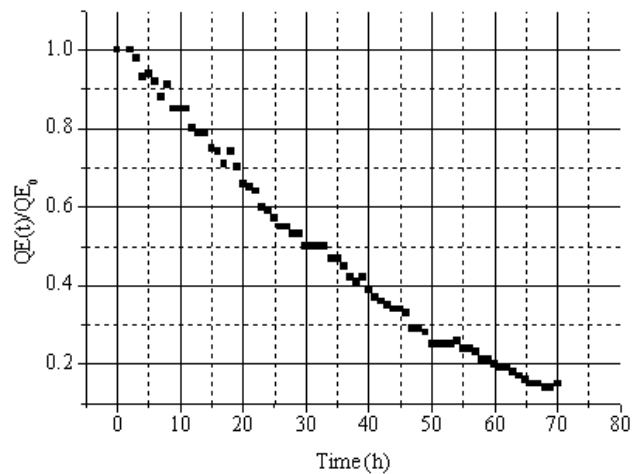

Figure 3: Preliminary result of dark-lifetime measurement.

To make the CAEP FEL-THz facility more practical, we hope upgrade the current continuance of 5 mA by an order of magnitude at least. The superb vacuum of the gun can be realized absolutely, and the ultimate pressure approaching 1E-10 Pa should be possible. According to the work schedule, the new gun can be completed in the end of 2014. With the advance on the technology of preparing NEA GaAs cathode, the target can be realized of elevating 5 mA continuance by order of magnitude.

REFERENCES

- [1] Triveni Rao and David H.Dowell, "DC/RF injectors," in *An engineering guide to photoinjectors*, CreateSpace, 2013.
- [2] Charles K.sinclair, "DC photoemission electron guns as ERL sources," *Nucl. Instr. and Meth. A*, vol. 557, pp. 69-74, 2006.
- [3] C.Hernandez-Garcia et al., "A high average current DC GaAs photocathode gun for ERLs and FELs," in *2005 Particle Accelerator Conference*, Knoxville, Tennessee, 2005, pp. 3117-3119.

- [4] Charles K. Sinclair, "A 500 kV photoemission electron gun for the CEBAF FEL," *Nucl. Instr. and Meth. A*, vol. 318, pp. 410-414, 1992.
- [5] Byung C. Yunn, "High brightness injectors based on photocathode DC Gun," in *2001 Particle Accelerator Conference*, Chicago, Illinois, 2001, pp. 2254-2256.
- [6] Spencer Acberman, Available: <http://www.wired.com/danger-room/2011/02/unexpectedly-navys-superlaser-blasts-away-a-record/>
- [7] G. Suberlucq, "Technological challenges for high brightness photo-injectors," in *European Particle Accelerator Conference 2004*, Lucerne, Switzerland, 2004, pp. 64-68.
- [8] SAES homepage, Available: <http://www.Saesgetters.com/default.aspx?idPage=125>
- [9] WANG Hanbin et al., "DC high voltage photoemission electron gun for CAEP FEL," in *33th International Free Electron Laser Conference*, Shanghai, China, 2011, pp. 598-600.
- [10] T. Nakanishi et al., "An electrode with molybdenum-cathode and titanium-anode to minimize field emission dark currents," in *2004 Linear Accelerator Conference*, Lübeck, Germany, 2004, pp. 645-647.
- [11] GK Laser homepage, Available: <http://www.gklaser.com/en/index.html>