

PERFORMANCE OF THE SINGLE-PASS POSITION MONITOR AT SOR-RING

Hirofumi Kudo, Kenji Shinoe, Hiroyuki Takaki, Tadashi Koseki,
Norio Nakamura, Yukihide Kamiya
Synchrotron Radiation Laboratory, Institute for Solid State Physics (ISSP),
The University of Tokyo, Tanashi, Tokyo 188, Japan

Tohru Honda

Photon Factory, High Energy Accelerator Research Organization (KEK),
Tsukuba, Ibaraki 305, Japan

Abstract

The R&D of single-pass beam position monitor is being carried out at SOR-RING, a 500-MeV electron storage ring. The bunch signals from four button electrodes are directly fed into a 4-channel digital oscilloscope through semi-rigid cables. The digitized data are sent to a workstation for the beam position calculation. The relative accuracy much less than 0.1 mm has been obtained with this system.

1 INTRODUCTION

The project for constructing a third-generation vacuum ultraviolet and soft X-ray synchrotron radiation source, VSX Light Source, is being planned by the University of Tokyo. In the fiscal year 1997, a budget for preliminary study of the facility has been appropriated by the government. The accelerator scheme consists of a 300-MeV linac, a 2.0-GeV booster synchrotron and a 2.0-GeV storage ring. The storage ring has a circumference of about 390 m and an emittance of 5 nm-rad [1].

Single-pass measurement of beam position are expected to play an important role in commissioning and tuning of the accelerator facility. A program to develop a single-pass monitor system using a fast digitizing oscilloscope is under way at 500-MeV electron storage ring, SOR-RING, in collaboration with the Photon Factory (KEK-PF) [2]. In this paper, we report the signal processing of the single-pass measurement and some recent results of the position measurement at SOR-RING.

2 BPM SYSTEM

SOR-RING is the first storage ring in Japan and also the first light source in the world for the dedicated use of synchrotron radiation from the beginning. Its construction was completed in 1974. The operation for synchrotron radiation experiment has been terminated at the end of the fiscal year 1996, and it is now operated only for the accelerator study and R&D's of the VSX facility.

Figure 1 shows a schematic view of SOR-RING. It is 17.4 m in circumference and consists of eight bending magnet (B1-B8) and four quadrupole triplets (Q1-Q4). The

RF frequency is about 120.9 MHz and the harmonic number 7. Electron beam of 308 MeV is injected into the ring from the Electron Synchrotron (ES) which belongs to the Tanashi branch of KEK. The injected beam is accelerated up to 500 MeV and then stored.

SOR-RING has four BPM's (BPM1 - BPM4) fixed on vacuum chambers of quadrupole triplets [3]. BPM consists of four pickup electrodes of a button type. The BPM system is usually used for C.O.D. measurement [4].

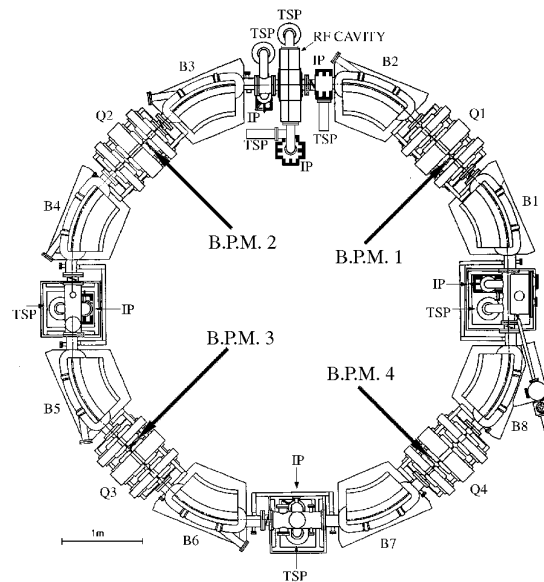

Figure 1: Plan view of SOR-RING.

In the beam transport (BT) line between ES and SOR-RING, there are three BPM's of a button type. The detailed description of the BPM's at BT appears in Ref. [2].

3 PERFORMANCE

For the single-pass monitoring, the bunch signals from four button electrodes are directly fed into a high-speed digitizing oscilloscope through semi-rigid coaxial cables (The cable for the ring is 2 m long and that for the BT line is 20 m long). The cable attenuation is 30

dB/100m at 100 MHz. The digitizing oscilloscope (Digital Real-time Oscilloscope, TDS684A by Tektronix) has four independent inputs. Each channel has a 8-bit digitizer with a maximum sampling rate of 5G samples/s and an analog bandwidth of 1 GHz. A maximum record length is 15000 points per channel. The digitized data are sent to a workstation (HP715) by GP-IB interface bus, and the beam position is calculated from the intensities of four button signals. The time duration of the button signal by a beam bunch at SOR-RING is about 3 ns, so that the sampling rate is fast enough to measure the waveform of the signal.

To calculate the beam position, the following two methods of data processing were adopted. The intensities of the button signals were obtained from (1) peak heights of the signals (The peak height method) or (2) peak height of an integrated waveform of the button signal (The integration method). Time span of the oscilloscope was set to 10 ns and the number of sampling data points N_s in the span was varied from 50 to 2500.

The relative accuracy of beam positions were estimated at a low beam current less than 5 mA in the single bunch operation of SOR-RING. Figure 2 shows the measured accuracy for the integration method; horizontal and vertical deviations from the average values are plotted. The number of sampling data points N_s is 500. Standard deviations σ less than 0.1 mm has been obtained.

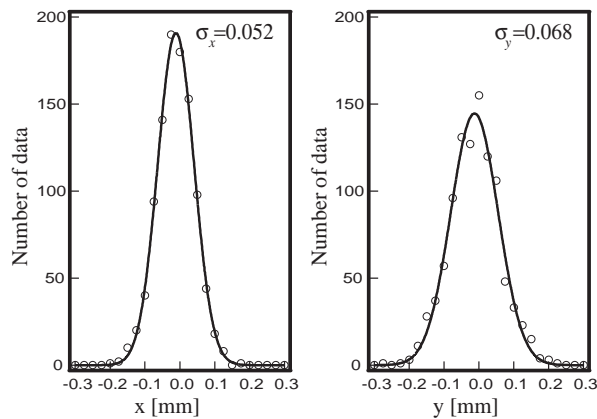

Figure 2: An example of relative accuracy.

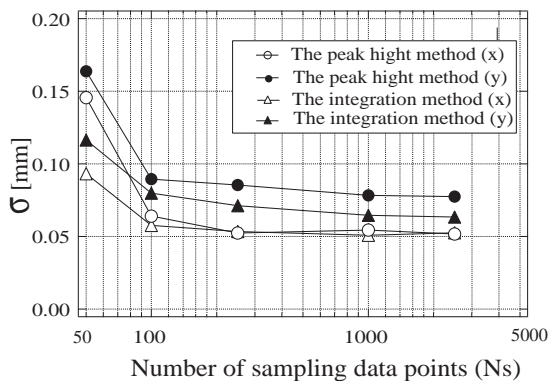

Figure 3: A comparison of relative accuracy between two data processing methods.

Figure 3 shows a comparison of relative accuracy σ between two methods. The abscissa is the number of data points N_s . Since the time span is 10ns and maximum sampling rate of the digitizer is 5 G samples/s, the data with N_s more than 50 were interpolated in the oscilloscope. The relative accuracy becomes almost constant more than $N_s = 250$. In this measurement, it is confirmed that the integration method gives higher accuracy than the peak-height methods. The accuracy of the integration method more than $N_s = 500$ seems to be limited by the 8-bit resolution of the digitizer.

4 BEAM POSITION MEASUREMENTS

4.1 Measurement using RF combiners

We measured the beam position at four BPM's of SOR-RING using RF power combiners. Figure 4 shows the schematic of the single-pass monitoring system with the RF combiners. The four button signals of the four BPM's were combined and then recorded in four channels of the oscilloscope. The same method is also adopted in the PF ring [5]. In the case of $N_s = 500$, the digitizer can store a time range of 0.3 μ s in maximum. As the revolution time of the SOR-RING is 57.8 ns, about 5 turns of bunch signals can be stored in the digitizer memory.

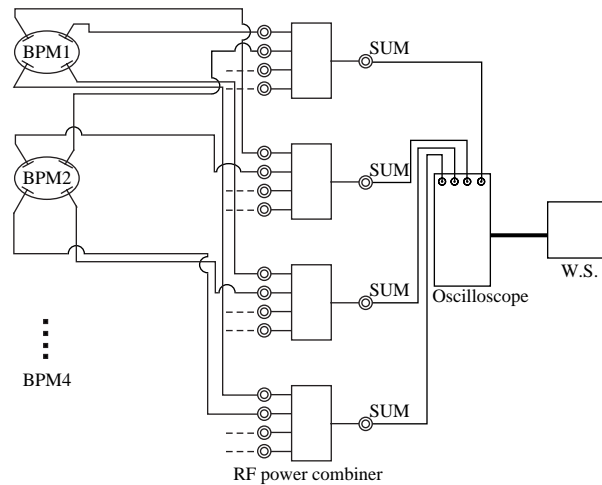

Figure 4: Schematic of single-pass monitoring system with RF power combiner.

Figure 5 shows the measured button signals of 5 turns in the single bunch operation of SOR-RING. A beam current was less than 5 mA for this measurement. The distance between two adjacent BPM's is 4.35 m and the time interval between two signals from adjacent BPM's is about 14.5 ns. As the time duration of a button signal is a few ns, the signals from the different BPM's were well separated each other. The calculated beam positions are

shown in Fig. 6. The dotted lines are measured beam positions and the solid lines are the deviations from the average of 5 turns. The accuracy using RF combiners is well agree with the results of Fig. 3.

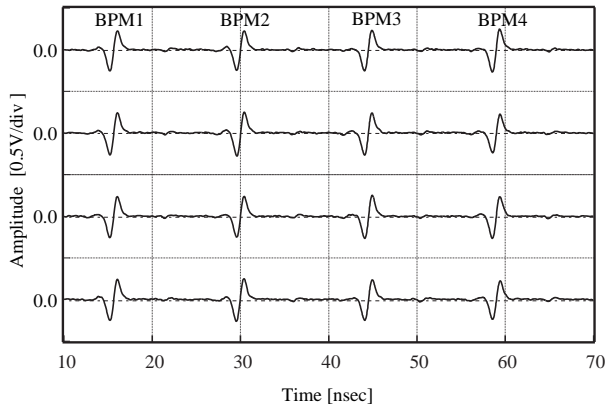

Figure 5: The measured button signals of 5 turns in the single bunch operation.

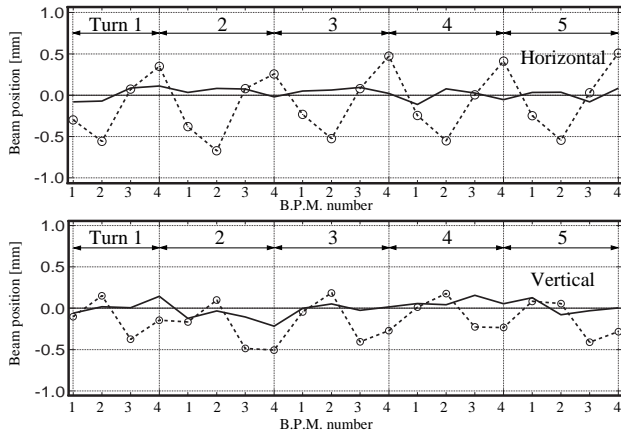

Figure 6: The measured beam positions of 5 turns in the single bunch operation.

4.2 Beam position of the BT bunch train

308-MeV electron beam extracted from ES is injected into SOR-RING with a repetition of 1 Hz. The beam positions at the BT line were measured by the single-pass monitor system. Figure 7 shows an example of the measured bunch train at one of the three BPM's of the BT line. 12 bunches were extracted from ES by the fast kicker magnet.

5 SUMMARY

The single-pass monitoring system using high-speed digitizing oscilloscope has been tested at SOR-RING. We have obtained the relative accuracy less than 0.1 mm. The system must be useful enough for the commissioning and tuning of the VSX accelerator facility. In the VSX storage ring, in which 128 BPM's will be installed, at least 8 BPM's will be used as the single-pass monitoring system with RF power combiner.

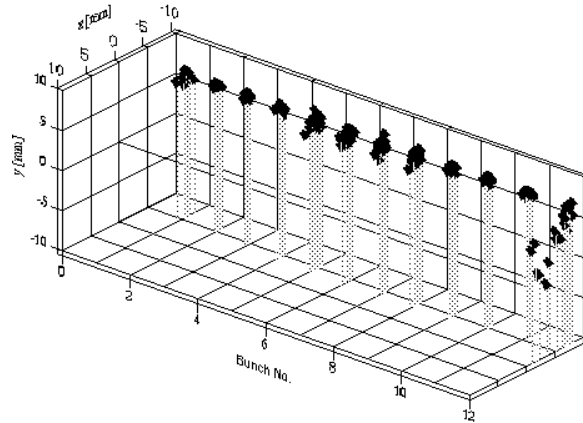

Figure 7: An example of the measured positions of bunch train at the BT line.

6 REFERENCES

- [1] H. Takaki *et al.*, "A Lattice for the Future Project of VUV and Soft X-ray High Brilliant Light Source" in these proceedings.
- [2] H. Kudo *et al.*, Proc. 5th European Particle Accelerator Conference, Barcelona, 1996, p. 1651.
- [3] K. Shinoe *et al.*, Proc. 1993 PAC, Washington, D.C., 1993, p. 2337.
- [4] K. Shinoe *et al.*, Proc. 1993 PAC, Washington, D.C., 1993, p. 2295.
- [5] T. Honda *et al.*, Proc. 5th European Particle Accelerator Conference, Barcelona, 1996, p. 1660.