

APT/LEDA RFQ VACUUM PUMPING SYSTEM

S. Shen, K. Kishiyama, J.M.Parker,
Lawrence Livermore National Laboratory, Livermore, CA and
N. G. Wilson, AMPRO, Inc., Los Alamos, NM and
D. Schrage, Los Alamos National Laboratory, Los Alamos, NM

Abstract

This paper describes the design and fabrication of a vacuum pumping system for the APT/LEDA (Low Energy Demonstration Accelerator) RFQ (Radio Frequency Quadrupole) linac [1]. Resulted from the lost proton beam, gas streaming from the LEBT (Low Energy Beam Transport) and out-gassing from the surfaces of the RFQ cavity and vacuum plumbing, the total gas load will be on the order of 7.2×10^{-4} Torr-liters/sec, consisting mainly of hydrogen. The system is designed to pump on a continual basis with redundancy to ensure that the minimal "operating vacuum level" of 1×10^{-6} Torr is maintained even under abnormal conditions. Details of the design, performance analysis and the preliminary test results of the cryogenic pumps are presented.

1 INTRODUCTION

The APTLEDA RFQ consists of four resonantly coupled two meter segments. The over-riding requirement for the APT/LEDA RFQ vacuum pumping system is that it be capable of pumping the combined gas load from the lost proton beam, gas streaming from the LEBT (Low Energy Beam Transport) and out-gassing from the surfaces of the RFQ cavity and vacuum plumbing. The total gas load will be on the order of 7.2×10^{-4} Torr-liters/sec. The main gas to be pumped will be hydrogen and the system must be able to pump hydrogen on a continual basis. Vacuum pumps are to be completely oil-free (both high-vac and roughing) and a single pump type must pump all other species of gas (O_2 , N_2 and any outgassed mixture). Redundancy must be provided in the system pumping and gauging to ensure that the minimal "operating vacuum level" of 1×10^{-6} Torr is maintained despite pump failures in the system. All pumps, valves and gauges must be replaceable without bringing the RFQ cavity up to atmospheric pressure.

2 DESIGN

2.1 Design Requirements

Tables 1 and 2 summarize the vacuum parameters and pumping system requirements for the APT/LEDA RFQ respectively.

PARAMETER	VALUE
Surface Outgassing Rate	2.4×10^{-9} Torr-liters/cm ² -sec 2.4×10^{-4} Torr-liters/sec
LEBT Gas Load (H ⁺)	1.1×10^{-4} Torr-liters/sec
H ⁺ Beam Loss (10 mA)	1.0×10^{-3} Torr-liters/sec
H ₂ ⁺ & H ₃ ⁺ Injection (2mA)	4.0×10^{-4} Torr-liters/sec
Total H ₂ Gas Load	1.4×10^{-3} Torr-liters/sec
TOTAL GAS LOAD	7.2×10^{-4} Torr-liters/sec
Pumping Ports	36 6-slots each 140 liters/second each
Pumping Plenums	3 @ Section A1 3 @ Section A2 3 @ Section C2

Table 1: Vacuum Parameters

PARAMETER	VALUE
Prototype for APT	System Must be Fully Suitable for APT Operation
Operating Pressure	$\leq 1.0 \times 10^{-6}$ Torr
System Time Constant	≤ 0.1 second
Pump Down Time	≤ 30 minutes
Concurrent Regeneration	Regeneration Must Occur During Operation
Installed Redundancy	System Must Operate with a Pump Failure During Regeneration
Redundant Gauging	False Positives Must be Detected
Standalone Operation	System Must Operate Independently of LEDA Control System
Control System Interface	System Must Accept Commands & Provide Signals to LEDA Control System
RF Window Vacuum	System Must Allow for Vacuum Pumping of 12 RF Windows
Safety/Codes	System Must Meet All Codes & Present No Safety Hazards

Table 2: Pumping System Requirements

2.2 Design Approach

Since the intent of the LEDA is that it will be a working prototype for the APT accelerator, it is imperative that the vacuum pumping system for the APT/LEDA RFQ be fully suited for actual APT operation. In developing the conceptual design for the vacuum pumping system we strove to meet the requirements set forth in the scope of work, and also expanded on those requirements by utilizing a "3 R's" approach in the design. We made a conscious effort to build in a *robustness* that will guarantee adequate pumping during all operating conditions of the accelerator.

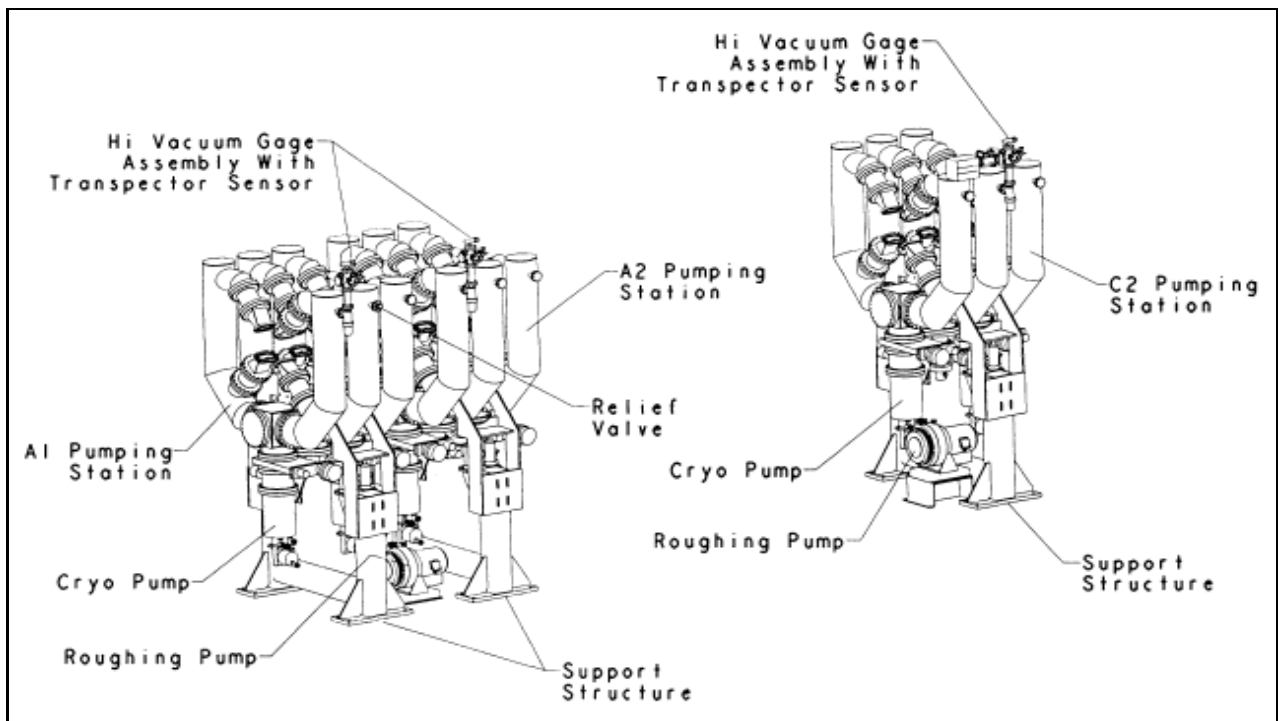

Fig. 1 RFQ Vacuum Pumping System

This was accomplished by researching and specifying *reliable* components in the system to safeguard against possible failures. In addition, we installed *redundancy* to counteract any unforeseen operating conditions or vacuum failures in the system.

2.3 System Design

Figure 1 shows the layout of the pumping stations and roughing system for sections A1, A2 and C2 of the RFQ. We opted to use cryopumps based on dynamic analysis of performance during both nominal and abnormal operations, as well as total system pumping speed versus cost. Two Varian DS-600 Dry Scroll Pumps were chosen for the roughing system. These pumps provide a total pumping speed of 1000 L/min at atmospheric pressure with an ultimate total pressure of 10^{-2} Torr and are totally hydro-carbon free as required. The system can be pumped down to below the cross-over pressure (~ 100 mTorr) of the cryopumps in such an arrangement within 30 minutes.

The majority of the pumping is located in sections A1 and A2 of the RFQ as most of the gas load occurs in the first two meters. Two 2200 L/s (for hydrogen) cryopumps are attached to the pumpstation at section A1, while section A2 has one 2200 L/s cryopump and a 500 L/min roughing pump. The vacuum headers of A1 and A2 are plumbed together via an 8" spool to allow cross-pumping between the two stations. The pumpstation at segment C2 of the RFQ is similar in configuration to that of A1 and A2, but contains two 2200 L/s cryopumps and one 500 L/min roughing pump.

Having a total of five cryopumps and two roughing pumps in the vacuum system guarantees the ability to individually regenerate cryopumps during accelerator operation. In addition, as shown in the analysis summary, the redundancy ensures that the "operating pressure" is maintained should one pump fail while another is in its regeneration cycle.

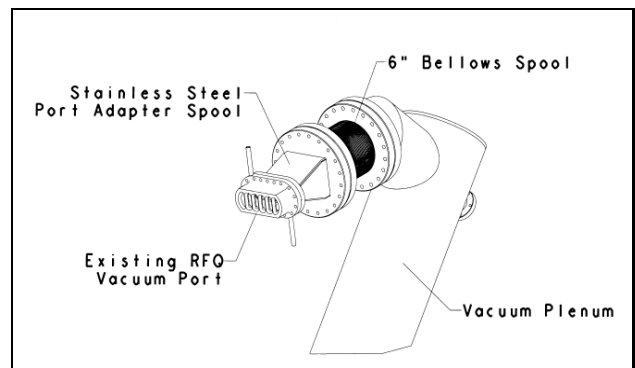

Fig. 2 RFQ Vacuum Port Adaptor Spool & Bellows Assembly

The port adapter spool shown in figure 2 is constructed from 304 stainless steel plate and an 8" conflat flange. It provides the transition from the RFQ vacuum port to the plenum. The 6 slot configuration of the RFQ vacuum port flange has the poorest conductance of any component in the system and the aggressive taper from the oval shape of the vacuum port flange to the circular plenum flange has a significantly higher conductance than would a straight oval or rectangular

spool transition piece. Since the RFQ cavities are fabricated from copper, it is difficult to provide a metal seal between the adapter spool and vacuum port. An o-ring groove, designed to accept a standard sized o-ring, is machined into the mating face of the adapter spool and a viton o-ring will provide the seal. This is the only connection in the high-vac system that will not have a metal seal. However, the RFQ vacuum port is water cooled to a temperature suitable for viton use.

3 SYSTEM ANALYSIS

Dynamic system analysis were carried out for pumpdown, nominal operation and under abnormal conditions. This was done by solving the coupled differential Heat-Load Equations described for each segment:

$$-V_i \frac{dP_i}{dt} = -Q_i + C (P_i - P_j) + K (2P_i - P_{i+1} - P_{i-1})$$

where V_i , Q_i and P_i represents the volume, gas load and pressure in segment i respectively. C is the total effective conductance of the RFQ pump ports, and K is the conductance of the coupling plates between two segments. P_j is the effective pressure at the port adaptor described by the equation for pump station j as:

$$-V_j \frac{dP_j}{dt} = S_j P_j - Q_j + C (P_i - P_j)$$

where S_j is the effective pump speed at the pump ports with all the conductance of the plumbing taken into account. One example of the analysis results is shown in Fig. 3. Description of the sequence of events is listed in Table 3.

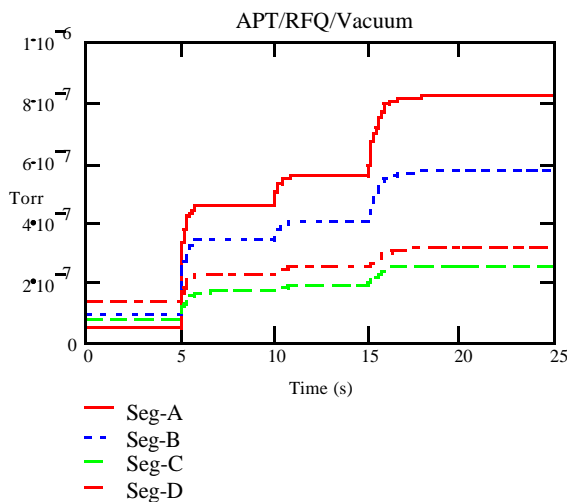

Fig. 3 Analysis Results of Simulation of Loss of Pumps in Segment A.

Time Interval (s)	Description
0 - 5	Base pressure with out-gassing load
5 - 10	With gas streaming from LEBT
10 - 15	With one pump out of service
15 - 25	With two pumps out of service

Table 3 Description Sequence of Events in Fig. 3

It is clearly shown that the minimum operating pressure of 10^{-6} Torr can be maintained even if two out of three pumps were taken out of service.

4 CRYOPUMP TEST

To verify the major design parameters, we have started a series of performance tests on the cryopumps procured for the system (Ebara ICP 200Q). Major tests include the measurements of H_2 pumping speed and H_2 capacity. We have adopted the standard test arrangement (AVS Procedure 4.1) [2]. Preliminary results of measured hydrogen pump speed are shown in Fig. 4. It should be noted that the measured value of 2700 L/s exceeds the vendor's specified value of 2200 L/s. Results of the pump speeds with H_2 quantity sorbed up to 30 L will be published at a later date.

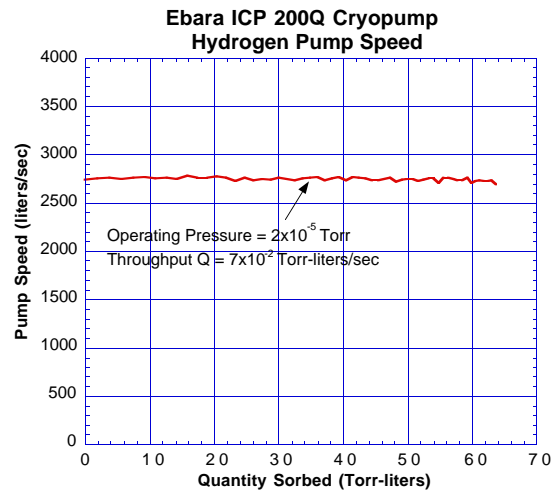

Fig. 4 Measured Pump Speed vs H_2 Quantity Sorbed

5 ACKNOWLEDGEMENTS

This work was performed under the auspices of the U.S. Department of Energy by Lawrence Livermore National Laboratory under Contract W-7405-Eng-48.

REFERENCES

- [1] D. Schrage: 'A 6.7 Mev CW RFQ Linac', *ibid.*, (2W.25)
- [2] M.H. Hablanian: 'Recommended Procedure for Measuring Pumping Speed', *J. Vac. Sci. Technol.* A5(4), July/Aug 1987, 2552