

# HIGH-GRADIENT CAVITY BEAT-WAVE ACCELERATOR AT W-BAND

D. H. Whittum, H. Henke<sup>†</sup>, and P. J. Chou\*,  
SLAC, Stanford University, Stanford CA, 94309

## Abstract

Pulsed rf heating is a fundamental limit on high-gradient acceleration in copper structures. Reduction of pulsed heating is favored by a short exposure time for the copper; yet in conventional accelerators, efficiency requires an exposure time of order a cavity fill time. At W-Band, the cavity beat-wave transformer concept permits efficient energy transfer to resonant accelerating modes on a sub-nanosecond time-scale. We re-examine this acceleration scheme as it appears at W-Band, with attention to drive beam dynamics.

## 1 INTRODUCTION

High energy physics today is limited by the accelerator, and little else. The most severe limit arises due to accelerating gradient, for machines of arbitrarily great dimension are not supportable by society. However, it is impossible to conceive of an electron collider operating with a gradient of, say, 1GeV/m, relying on known collider concepts and technology. Inventions are required.

For the linac proper one must account for *trapping*, *breakdown*, and *pulsed heating*. Trapping refers to the acceleration from rest of field-emitted electrons in the structure. The gradient  $G$ , and wavelength  $\lambda$ , may be related to the trapped fraction  $F$ , by means of the binding field expression [1], with the result,

$$G\lambda = 3.2MV\left\{1 - \sin\left[\pi\left(F - \frac{1}{2}\right)\right]\right\}^{-1}.$$

Breakdown is a phenomenological problem at present, but it does exhibit a clear pulse length dependence. For a pulse length equal to the natural fill-time of a travelling wave structure with attenuation parameter  $\tau=1$ , experience at S and X Band is consistent with a limit on electric field [2],

$$E_{br} \approx 25 \frac{MV}{m} f^{1/2} (1 + 2.7 f^{3/8}),$$

where  $f$  is the rf frequency in GHz. Pulsed heating refers to the sudden deposition of heat, by Ohmic loss, in the conducting structure. For a pulsed temperature rise  $\Delta T$ ,

$$G\left(\frac{GeV}{m}\right) = 0.25\left(\frac{\Delta T}{40^\circ K}\right)^{1/2} \left(\frac{f}{91.4GHz}\right)^{1/4}$$

<sup>†</sup> On sabbatical from Technische Universität Berlin.  
\* Supported by the DOE Contract DE-AC03-76SF00515.

for an idealized rectangular pillbox cells, in a constant gradient structure with attenuation parameter  $\tau=1$ , and pulse length equal to a fill time. These scalings are depicted in Fig. 1. Also seen are gradients achieved to-

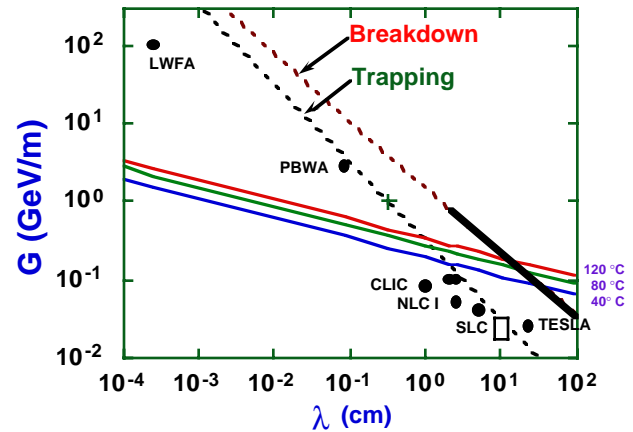

Figure: 1 Current state of the art in high-gradient accelerator research.

date, versus accelerator wavelength. Overlaid are the trapping condition, an extrapolation of known breakdown scalings, and curves of constant pulsed temperature rise. The fit to empirical breakdown results extends only over the solid portion of the curve. Also shown are recent results for the Laser Wakefield Accelerator (LWFA) [3] and the Plasma Beat-Wave Accelerator (PBWA) [4]. Points corresponding to the 0.5TeV collider concepts are also depicted [5]. Shown but not labelled are DESY S-Band, NLC II, VLEPP, and KEK C-Band. The block marked "SLC" extends from 20MV/m as for a typical structure, to 40MV/m as for certain higher gradient structures on the linac.

These scalings imply that *high-gradient* requires *short-wavelength*. For a 1 GeV/m linac, interest begins in the *W-Band*, 75-110GHz. We have added a cross-mark in Fig. 1 as a helpful landmark, corresponding to 1 GeV/m. The corresponding frequency is close to 91.4GHz (3.3mm), the 32nd harmonic of the SLC fundamental frequency, 2.856GHz.

The curves of pulsed temperature rise make clear too, that such a linac will suffer severe pulsed heating, and the conventional travelling wave structure we have taken as our paradigm, will surely fail short of 1 GeV/m.

To be sure, it is yet an open question exactly what cyclic pulsed temperature rise a structure can withstand, and this is the subject of ongoing research [6]. It should also be emphasized that the technology of handling high mm-wave power does not yet extend to the 150-200 MW level one would require to establish GeV/m gradients. Based on experience at longer wavelengths, one would expect to find serious problems with field emission. Field emitted current density takes the form,

$$J\left(\frac{A}{m^2}\right) \approx 6 \times 10^{-11} (\beta E)^{2.5} \exp\left(-\frac{6.2 \times 10^4}{\beta E}\right),$$

with  $E$  the theoretical surface field in MV/m, and  $\beta$  a phenomenological "field-enhancement factor" typically 50-100, depending on the state of the surface (composition, cleanliness, finish) [7]. Such a field enhancement would result in explosive emission at GeV/m gradients, and would be unacceptable. At the same time, there is experimental evidence that field emission is inhibited on short, ns time-scales [8], and this is encouraging insofar as the natural fill time for a W-Band structure is on the order of 10ns.

## 2 CBWA CONCEPT

This problem of pulsed heating can be solved in principle by a radically different acceleration technique, first proposed by Henke [9]. The concept is of the two-beam type and promises the high-efficiencies often discussed in connection with such schemes. It is depicted in Fig. 2, consisting of two beamlines, and two side-coupled cavities. The coupling between the two cavities, for the case of isolated resonances, may be characterized by the beat-period  $T_b$ .

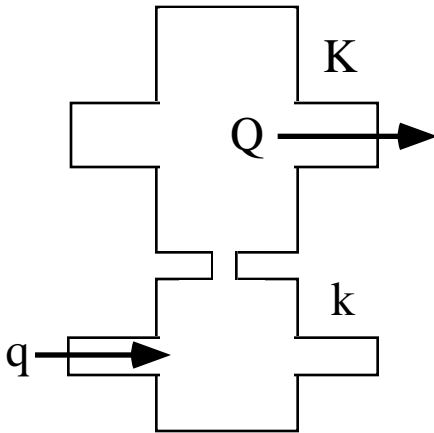

Figure: 2 One period of a CBWA, consisting of two beamlines and two side-coupled cavities.

A drive bunch of charge  $Q_b$  passing through the drive cavity will deposit energy  $W=KQ_b^2$  in the fundamental mode, characterized by loss-factor  $K$ . Total energy loss,

all modes considered will be larger by a factor  $B>1$ . The corresponding average decelerating voltage in the drive cavity is  $V=KQ_b$ . In a time  $T_b/4$ , this energy will appear in the accelerating cavity, characterized by loss factor  $k$ , corresponding to a no-load accelerating voltage,  $v=2(kK)^{1/2}Q_b$ . The transformer ratio is then  $R = v/V = 2(k/K)^{1/2}$ . This energy subsequently reappears in the drive cavity, and can be extracted by a second drive bunch, modulo higher mode losses and wall losses in a beat period.

To evaluate these scalings additional ingredients are required. Given the desired wavelength for operation (3.3mm) geometry constrains  $k$  to at most  $\sim 32V/pC$ , and a more conservative value, including reduction due to beam ports would be 13V/pC. Finally, pulsed heating in the drive cavity requires that the decelerating voltage not be too large. We will take  $R \sim 5$ . Assuming cavities spaced at 1/3 of a wavelength, one arrives at the parameters indicated in Table 1. The problem with the concept is clearly indicated in the last row: an enormous drive charge is required. From the point of view of single-bunch beam dynamics, this is *untenable*.

Table 1 Example Parameters for a W-Band CBWA

Parameter	Value
Drive Cell Loss Factor $K$	2 V/pC
Drive Cell $[R/Q]$	14 $\Omega$
" per unit length	13 k $\Omega$ /m
Accelerating Cell $[R/Q]$	90 $\Omega$
" per unit length	82 k $\Omega$ /m
Peak Accelerating Gradient	1 GeV/m
Avg Decelerating Gradient	200 MeV/m
Drive Cell Avg Voltage $V$	220 kV
Drive Charge $Q_b$	110nC

Thus despite any attractive features of the concept, it is clear that the first and most important flaw is stability of the drive beam. To attempt to repair the transverse dynamics, one can split the drive charge up, employing a bunch train. To hold pulsed heating to 200°K, one needs a quarter-beat period of 300ps. Thus at most 30 W-Band periods are available for the drive bunches, and one requires a bunch charge of 5nC. We consider next the transverse stability of such a bunch train.

## 3 DRIVE-BEAM DYNAMICS

From the foregoing discussion it is clear that the beat-wave accelerator requires an intense drive beam to propagate through mm-dimension apertures. Having required the drive beam to interact strongly with the fundamental mode of the structure, one suspects it will obligingly find other modes of the structure to drive. For the longitudinal wake, one's concerns may be allayed to some degree by the enlarged beam aperture presumed by the lower  $[R/Q]$  of the drive structure. The transverse

wake, however, requires special attention. While the low  $[R/Q]$  is favorable for transverse wake reduction, the drive beam charge is quite high, and one must consult the details of the scalings for beam break-up to assess the viability of the concept. The beam centroid  $\xi$  satisfies,

$$\left(\frac{\partial}{\partial z}\gamma\frac{\partial}{\partial z} + \gamma k_{\beta}^2\right)\xi = \int_0^{\tau} d\tau' \frac{I_b(\tau')}{I_0} W(\tau - \tau') \xi(\tau', z),$$

with  $I_b$  the beam current, and  $I_0 \sim 17\text{kA}$ . We take as a model wakefield a single dominant, damped mode,

$$W(\tau) = W_0 \sin(\Omega\tau) \exp\left(-\frac{\Omega\tau}{2Q}\right).$$

The wakefield amplitude takes the form,  $W_0 = \hat{w}\omega^3/c^2$ , where the dimensionless amplitude  $\hat{w} \sim 1$  for a closed pillbox, and diminishes as the beam-portal is widened.

Treating the drive beam current waveform as constant, and assuming strong-focusing, asymptotic growth for an initial offset  $\xi_0$  takes the form [10],

$$\frac{\xi}{\xi_0} \approx 0.2 \frac{A^{1/2}}{\Omega\tau} \exp\left(A - \frac{\Omega\tau}{2Q}\right),$$

with exponent,

$$A = \left(\frac{z\tau}{\gamma k_{\beta}} \frac{I_b}{I_0} W_0\right)^{1/2}.$$

If the  $Q$  for the dipole mode is sufficiently low, such that  $\tau > \tau_{sat} = zW_0Q^2/\gamma k_{\beta}\Omega^2$  asymptotic growth is a maximum at  $\tau = \tau_{sat}$ , scaling as  $\xi_{sat}/\xi_0 \approx 0.3e^{A'}/QA'^{1/2}$  where the exponent is  $A' = zW_0Q/2\gamma k_{\beta}\Omega$ . These scalings are quite harsh for a drive beam charge in the range of 110nC. For example, even with an extremely low  $Q \sim 2$ , a high drive beam energy  $\sim 1\text{GeV}$ , and a modest range  $z \sim 100\text{m}$ , and assuming an extremely low wakefield amplitude,  $\hat{w} \approx 0.1$ , one can hold the saturated growth to  $\xi_{sat}/\xi_0 \approx 14$  only by means of a very short betatron period,  $\lambda_{\beta} \approx 2\pi/k_{\beta} \approx 10\text{cm}$ . Such strong focusing is not out of the question, for example, with ion-channel guiding. While other cures are available [10], the research emphasis for such a concept is clear: single-bunch wakefield analysis for a large aperture geometry, one that implements very strong damping of multibunch wakefields, and, if exotic focusing mechanisms are to be avoided, then detailed design and

analysis of small aperture magnets for mm-wave structures, along the lines of the work by Hill [11].

## 4 CONCLUSIONS

The cavity beat-wave transformer permits efficient use of rf in strongly coupled (high  $[R/Q]$ ) accelerating structures, while limiting the time to which copper is exposed to high fields, to the range of several hundred ps. This cannot be accomplished in a conventional travelling wave structure, constrained by the fill time and bandwidth product. In the limit of 100's of ps exposure time, pulsed temperature rises can be held to below 200°K. It is an open question whether such heating is acceptable [6,7]. At the same time, the beat-wave concept suffers, as all two-beam concepts do, from the need for an intense drive beam, and the attendant problems for the drive beam dynamics.

## REFERENCES

- [1] M. Chodorow, *et al.*, Rev. Sci. Instrum. **26** (1955) pp. 134-204.
- [2] A.E. Vlieks, *et al.*, *Breakdown Phenomena in High-Power Klystrons*, SLAC-PUB-4546, presented at the XIIIth International Symposium on Discharges and Electrical Insulation in Vacuum (Paris, June, 1988). P.B. Wilson (private communication).
- [3] The Rutherford Appleton Lab LWFA work made use of a 25TW, 0.8ps laser pulse with peak intensity  $10^{19}\text{W/cm}^2$ , producing an inferred plasma density of  $10^{19}\text{cm}^{-3}$ , and  $10^7$  44MeV electrons of  $\sim 5\text{mm-mrad}$  normalized emittance. The inferred gradient was 100GV/m.
- [4] C.E. Clayton, *et al.*, Phys. Rev. Lett. **70** (1994) 37, and Phys. Plasma **1** (1994) 1753. The UCLA PBWA work made use of a 0.2TW, 1ns laser pulse with peak intensity of  $10^{14}\text{W/cm}^2$ , in a  $10^{16}\text{cm}^{-3}$  plasma. It produced up to 28MeV electrons for an inferred gradient of 2.8GV/m.
- [5] *International Linear Collider Technical Review Committee Report*, G. A. Loew and T. Weiland, eds, (July 1995) SLAC-R-95-471.
- [6] D. Pritzkau, *et al.*, these proceedings.
- [7] G. A. Loew and J. W. Wang, *RF Breakdown Studies in Room Temperature Electron Linac Structures*, SLAC-PUB-4647, presented at the XIIIth International Symposium on Discharges and Electrical Insulation in Vacuum (Paris, June, 1988).
- [8] F. Villa and A. Luccio, *Test of a High-Gradient Low-Emittance Electron Gun*, June 1996 (Laser and Particle Beams, *to be published*).
- [9] H. Henke, *Cavity Beat-Wave Transformer for a Two-Beam Accelerator*, CERN-LEP-RF/88-55
- [10] D.H. Whittum, *et al.*, Phys. Rev. A **46** (1992) 6684.
- [11] M. Hill, *A Study of a Planar Six-Wire Quadrupole Magnet Design*, TET-Note-96/08, Technische Universität Berlin (1996).