

RF SIMULATIONS OF THE INJECTOR SECTION FROM CH8 TO CH15 FOR MYRRHA*

P. Müller[†], M. Busch, K. Kümpel, D. Mäder, N. Petry, H. Podlech
 IAP Goethe University, Frankfurt, Germany

Abstract

MYRRHA (Multi-purpose hYbrid Research for High-tech Applications) is the first prototype of an accelerator driven nuclear reactor dealing with transmutation of long-living nuclear waste [1]. Beam quality and reliability are crucial for the reactor. The injector design is done by IAP, Goethe University Frankfurt, and has been adapted to the final magnet design and voltage distributions. The energy section from 5.9 MeV up to 16.6 MeV [2] has been changed to normal conducting CH cavities [3] as in the lower energy section of the injector. For beam adjustment a 5-gap CH cavity rebuncher at 5.87 MeV as well as two doublet magnets forming the new MEBT-2 section between CH7 and CH8 has been added. Starting parameters for the RF simulations have been given by beam dynamics results calculated with LORASR. RF simulations of these structures consisting of flatness and tuning optimizations will be presented within this contribution.

Therefore a sufficient cooling channel layout is necessary and the design is currently ongoing for the last structures. Detailed results will be presented for CH8, which is shown in Figures 1 and 2.

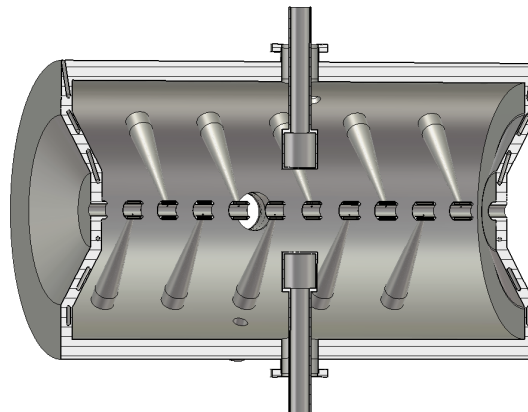

Figure 2: Sectional view of CH8.

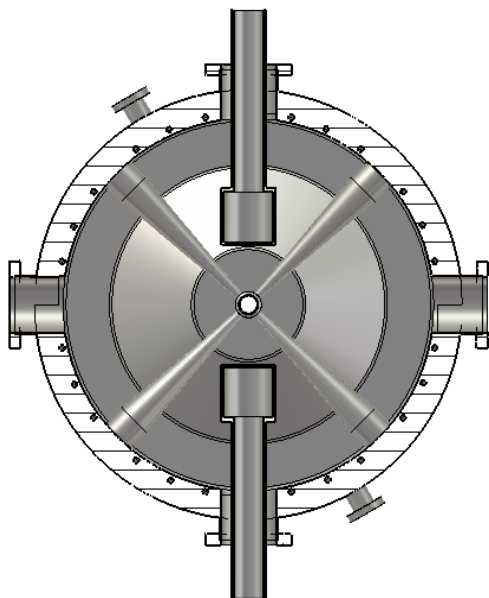

Figure 1: Sectional view of CH8.

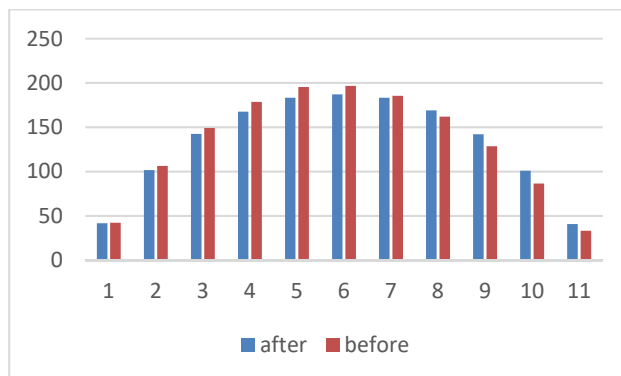

Figure 3: Voltage distribution before and after flatness optimization.

INTRODUCTION

CH8 – CH15 as well as the rebuncher CHR operate at 176.1 MHz. The gap mid distances result from the beam dynamic calculations via LORASR. Improved voltage flatness was achieved through the change of the gap lengths and of the lid depth. The RF simulations were performed with CST Microwave Studio [4]. CH8- CH15 have power losses at the range of 36-38 kW with their corresponding 90% value of the respecting shunt impedance, which is shown in Table 1.

RF PROPERTIES

Figure 3 shows the improvement of the voltage flatness of CH8. The flatness was primarily improved by the change of gap length. Lid depth was also changed from 80 mm to 100 mm for CH9-CH15. The result of the lid depth change is an increase of outer gap voltages by 2 kV. The lid depth for CH8 is left unchanged, because of the uncertainty of other beam line elements dimensions close to CH8. In order to meet the resonance frequency of 176.1 MHz, the tank radius was adjusted accordingly to 326.17 mm. The plunger head was predetermined with the radius of 97.5 mm and 100 mm height. This exceeds the minimal required frequency range of 0.5 MHz for all structures. Respect has been given to the parasitic tuner mode, which couples to the resonator modes close to its frequency as shown in Figure 4. The frequency gap between the tuner mode and the H₂₂₁ mode far exceeds the required 1 MHz for all structures at all relevant positions.

* Work supported by MYRTE and HIC for FAIR.

[†] P.Mueller@iap.uni-frankfurt.de

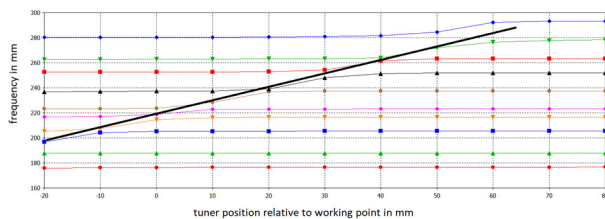

Figure 4: Shows the linear relation between the tuner mode frequency and the plunger penetration depth. The tuner mode couples to the modes close in frequency.

Table 1: RF Properties of CH8-CH15

#	Gaps	Phase [°]	U_a [MV]	Z_{eff} [MΩ/m]	P_C [kW]
8	11	-18	1.46	56.6	37.5
9	12	-18	1.53	53.3	36.7
10	12	-20	1.53	49.4	37.5
11	11	-20	1.46	47.8	37.5
12	10	-22	1.39	43.1	38.3
13	10	-22	1.39	41.5	37.9
14	9	-20	1.32	40.1	36.7
15	9	-18	1.32	38.8	35.5

Z_{eff} is the calculated CST value. P_C is calculated with 90% of the CST impedance value to compensate simulation inaccuracies. All cavities operate at 176.1 MHz and have a similar quality factor above 17000.

THERMAL PROPERTIES AND COOLING SYSTEM

The cooling system of CH8- CH15 shown in Figures 5 and 6 is similar to the cooling system of the cavities CH1-CHR [3]. The cooling of the lids and the tuner are left unchanged. The increase in length of the cavities made a divided tank cooling system layout necessary.

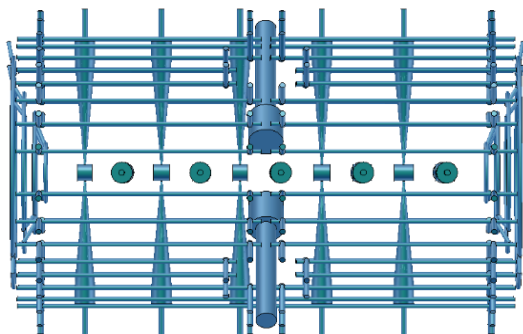

Figure 5: Cooling System of CH8 (side view).

The 30mm cooling gap has to be positioned at a noncritical part of the tank, in order to minimize temperature increase. For structures with stems directly in the middle of the tank, the cooling gap is placed behind the stem otherwise the gap is at the middle. Increase in temperature is compensated by two additional divided cooling channels per flange, which sums up to 8 additional divided cooling channels.

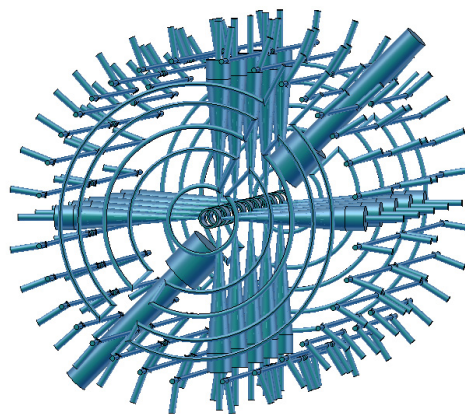

Figure 6: Cooling system of CH8 (front view).

Thermal simulations were performed in CST using the 90% shunt impedance value to account for the inaccuracy of the RF simulations. In thermal simulations the cooling system is represented as a static temperature source. For compensation 3 kW have been added to respect this simplification. Figure 7 shows the corresponding thermal distribution of CH8.

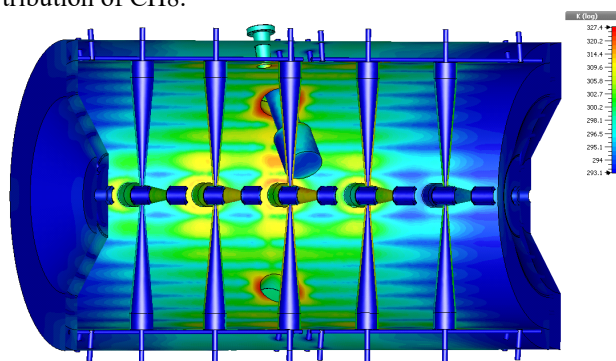

Figure 7: Temperature distribution of CH8 for 39 kW.

SUMMARY

RF simulations have been successfully performed and will go through one more beam dynamic calculation via LORASR. The cooling channel layout of CH1-CHR has been adapted for CH8-CH15 and has been successfully simulated for most structures. Calculations for the last two structures are currently ongoing.

ACKNOWLEDGEMENT

This work was supported by MYRTE which is funded by European Commission under Project ID 662186 and by HIC for FAIR.

REFERENCES

- [1] D. Vandeplasseche, J.-L. Biarrotte, H. Klein, H. Podlech, “The MYRRHA Linear Accelerator “, in *Proc. 2nd International Particle Accelerator Conf. (IPAC'11)*, San Sebastian, Spain, Sep. 2011, paper WEPS090, pp. 2718-2720.
- [2] C. Zhang, H. Podlech, “New Reference Design of the European ADS RFQ Accelerator for MYRRHA “, in *Proc. 5th International Particle Accelerator Conf. (IPAC'14)*, Dresden, Germany, June 2014, paper THPME008, pp. 3223- 3225.
- [3] K.Kümpel, D.Mäder, P.Müller, N.F.Petry, H.Podlech, “The New Injector Design For MYRRHA“, in *Proc. 8th International Particle Accelerator Conf. (IPAC'17)*, Copenhagen, Denmark, May 2017, paper TUPVA068, pp. 2234-2236, doi:10.18429/JACoW-IPAC2017-TUPVA068
- [4] CST MICROWAVE STUDIO, <http://www.cst.com>

Content from this work may be used under the terms of the CC BY 3.0 licence (© 2018). Any distribution of this work must maintain attribution to the author(s), title of the work, publisher, and DOI.