

DARESBURY LABORATORY SHORT PULSE KLYSTRON MODULATORS

Christopher Chipman, Dr. Marcel P.J. Gaudreau, PE, Luan Jashari,

Michael Kempkes, John Kinross-Wright, Rebecca Simpson

Diversified Technologies, Inc., Bedford, MA 01730, USA

Stephen Griffiths, Alan Wheelhouse

STFC - Science & Technology Facilities Council, Swindon, United Kingdom

Abstract

Diversified Technologies, Inc. (DTI) is building three solid-state klystron transmitters Daresbury Laboratory in England. The units provide very high peak power.

Index Terms — Klystron; Daresbury; LBNL; Solid-State Modulator; High Voltage Pulse-Transformer

INTRODUCTION

Diversified Technologies, Inc. (DTI) is delivering three identical solid-state pulsed klystron transmitters to Daresbury Laboratory in the United Kingdom for the CLARA project [Fig. 1]. The modulators are designed to provide 250 MW peak power to pulse 80 MW-class klystrons at an average beam power of 250 kW at 400 Hz pulse frequency, and provide adjustable high efficiency operation in the 45 kV to 450 kV range for currents up to 545 A and pulse lengths of 1.5 to 4.0 μ s. The system is upgradable to 1 kHz pulse frequency with the addition of a second HVPS (see Table 1).

One key objective of this modulator development is optimization of voltage flatness (± 0.02 %), stability (± 0.05 %), and reproducibility (± 0.05 %). These modulators are a direct extension of the systems delivered to Law-

rence Berkeley National Laboratory and Daresbury Laboratory in 2014, with a pulse transformer-coupled hybrid system.

MODULATOR

These 250 MW peak power modulator systems employ a relatively simple modulator design, which consists of an energy storage capacitor, a high voltage series switch, a step-up pulse transformer, and a passive pulse-flattening circuit [Fig. 2 and Fig. 4]. This arrangement gives an extremely flat pulse and allows the use of a moderate value of storage capacitor. The DTI switch can open or close as commanded, so the pulse width is adjusted by the gate pulse to the system. Each system will employ a 35 kV primary voltage supplied by a DTI high voltage switching power supply. This allows optimization of all components to give a simple, reliable, and high stability system.

The modulator tank lid is split into three separate sections for ease of service. The primary section of the tank houses the solid-state switches, with the main storage capacitor and pulse-flattening circuitry in the center section. The third section of the tank houses the pulse transformer and klystron tube socket.

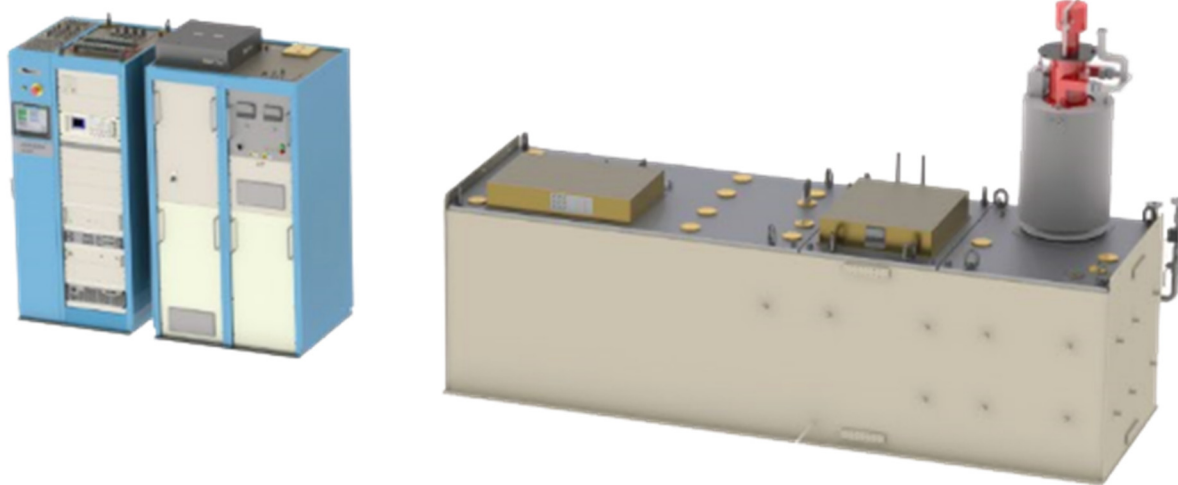

Figure 1: 250 MW Peak Power CLARA Klystron Modulator System. High voltage solid-state switching allows a simple and reliable modulator with extremely high pulse fidelity and stability. One rack houses low voltage circuitry and controls (left) while a double-wide rack houses DTI's standard high voltage power supply and step-up AC transformer (center), allowing standard US 480 VAC input to the HVPS from 380 VAC British power.

DTI HIGH VOLTAGE SOLID-STATE SWITCHES

A high voltage switch is a crucial, proven building block of most DTI transmitters. The switch consists of a series/parallel combination of commercially-available insulated gate bipolar transistors (IGBTs). Under normal operation, the switch acts as a modulator, controlling the pulses to the pulse transformer. In addition to providing pulsing, another important function of the switch is circuit protection. When a klystron gun arc occurs, the fault is sensed and the switch will open in less than 1 μ s to disconnect high voltage. The current rate of rise is limited to a safe value by the inductance of the pulse transformer. This rapid current interruption minimizes the fault energy deposition in the klystron gun which promotes a long and stable valve lifetime. These characteristics make the solid-state opening switch an ideal building block for high availability applications such as particle accelerators and mission critical radars. A large high voltage design margin is included at both the individual switch stages and for the overall switch assembly, so that several switch module failures could be tolerated without affecting system performance.

PULSE TRANSFORMER

The primary voltage of the DTI switch allows a moderate transformer step-up ratio ($\sim 14:1$). This gives fast rise and fall times and high efficiency. The transformer is built by Stangenes Industries (Palo Alto, CA) to our detailed specifications, and has a bifilar wound secondary on a sloped basket (constant gradient). The transformer

design is optimized to work with the passive pulse flattening circuit to give a very good flat top. A commercial power supply in the rack supplies the DC core reset current for the transformer, fed through a core reset inductor.

Table 1: Key Specifications of the Klystron Modulator

Specification	Value	Unit
Peak RF Power	80	MW
Voltage Range	45 – 450	kV
Beam Current	50 – 545	A
Modulator Peak Power	> 245	MW
Average Power	250	kW
Pulse Width	0.25 – 3.0	μ s
Repetition Rate	1 – 400	Hz
Voltage Flatness	$< \pm 0.02\%$	1 μ s at 400 Hz 2 μ s at 100 Hz
Pulse to Pulse Voltage Stability	$< \pm 0.05\%$	of Vmax
Voltage Reproducibility	$< \pm 0.05\%$	Of Vmax
Pulse to Pulse Jitter	$< \pm 1$	ns

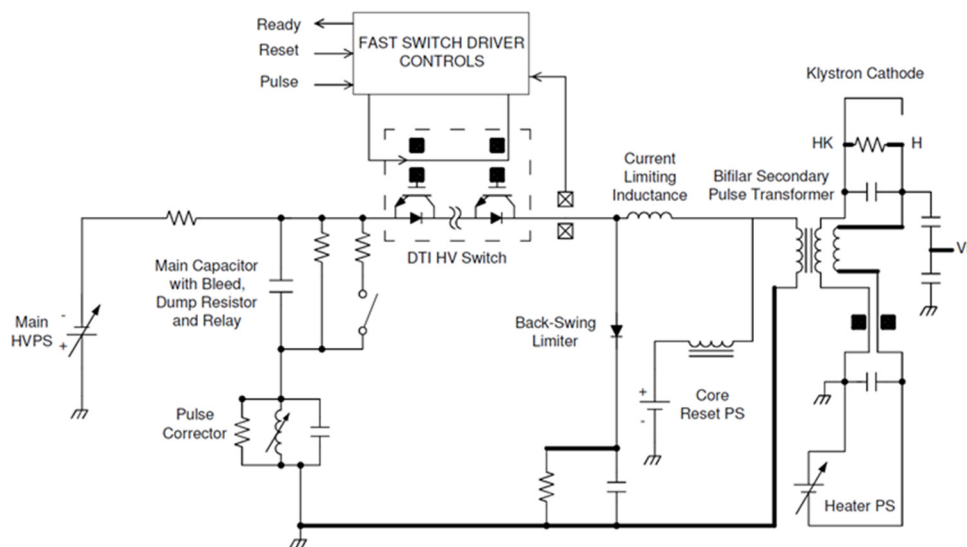

Figure 2. Simplified modulator schematic. Directly switching 35 kV on the primary simplifies the pulse transformer and improves the risetime compared to higher step-up ratio designs. Series IGBT switches have inherent redundancy such that several modules may fail before system performance is affected.

Content from this work may be used under the terms of the CC BY 3.0 licence (© 2018). Any distribution of this work must maintain attribution to the author(s), title of the work, publisher, and DOI.

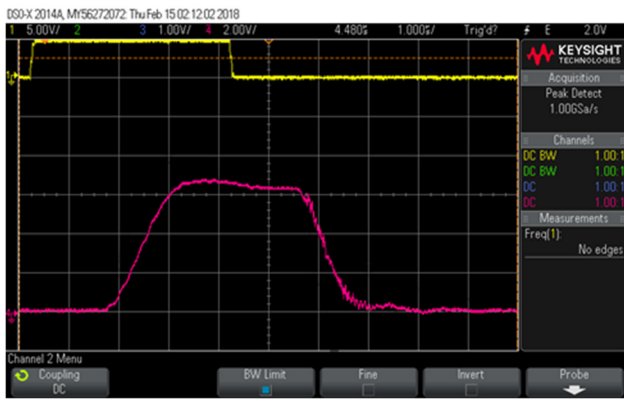

Figure 3: Factory Test of System #1 into a resistive load. Pulse conditions were 420 kV, 400 A, 4 μ s flattop, and without the pulse flattening circuit in operation. The overshoot in the voltage pulse disappears into a perveance load. Scale is 1 μ s per division. Trace 1 – Pulse Command; Trace 2 – Voltage.

SYSTEM PERFORMANCE

Klystron pulse voltage flatness and stability are crucial to proper LINAC operation. The first of three modulator systems met all technical specifications of the Compact Linear Accelerator for Research and Application (CLARA) in factory testing [Fig. 3]. The modulator will be optimized near the nominal peak power of the klystron during site installation and testing. DTI systems are inherently amenable to modification for potential system upgrades in the field. The modulator has the capability to run approximately 10% over the nominal output voltage of 450 kV.

The simple DTI pulse circuit includes a storage capacitor, pulse flattening circuit, and solid-state high voltage switch on the primary side of the pulse transformer to give a very flat pulse with rapid rise and fall times. Any small imperfections are removed by the passive pulse compensation

circuit. Using the pulse flattening adjustment design, a peak voltage flatness of $\pm 0.02\%$ or better will be achieved for 1 μ s at 400 Hz and for 2 μ s at 100 Hz. SPICE simulations indicate flatness of less than $\pm 0.01\%$ is possible; the value of $\pm 0.02\%$ allows margin for real world conditions.

RELIABILITY

DTI has installed high voltage transmitter systems for numerous high reliability and high maintainability applications, such as military shipboard radars and high power physics experiments. A combination of conservative design and low operating temperatures (typically 20 – 30 $^{\circ}$ C junction temperature rise in the IGBTs) contributes to the high reliability of DTI’s equipment. The vast majority have had no known field failures after initial commissioning, and DTI systems have achieved over 120 system-years of failure free operation.

DTI’s high voltage solid-state opening switch technology minimizes the stress on the system in the event of a fault (such as a tube arc). This contributes to long tube life and high availability and allows for rapid recovery in the event of most faults. In addition, these diagnostics allow for the rapid detection and isolation of repetitive or hard faults in the overall system. The estimated mean time to repair (MTTR) with the recommended spares on site is 4 hours. This results in a system availability of over 99.99 %.

CONCLUSION

DTI designed and built the 250 MW klystron modulators based on its previously delivered short pulse modulator systems, and input from the users at Daresbury Laboratory. The first of three systems has completed factory testing, and shipped to Daresbury Laboratory for installation in May, 2018. The second and third systems are due to be shipped and installed in the summer of 2018.



Figure 4: 250 MW Modulator construction, with the pulse transformer in front, and the switch modules at the rear. The energy storage capacitors are visible in the center section. This entire assembly is submerged in an oil tank for operation.