

# MONOENERGETIC BEAM GENERATED BY LASER ACCELERATOR AT PEKING UNIVERSITY

K. Zhu<sup>†</sup>, J. G. Zhu, C. C. Li, M. J. Wu, Q. Liao, Y. X. Geng, X. H. Xu, D. Y. Li, Y. R. Shou, J. Q. Yu, C. Lin<sup>†</sup>, W. J. Ma, H. Y. Lu, Y. Y. Zhao, C. E. Chen, X. Q. Yan  
Peking University, 100871 Beijing, China

## Abstract

The Compact Laser Plasma Accelerator (CLAPA) is being built to deliver a proton beam with an energy of 1–10 MeV, an energy spread of  $\pm 1\%$  and  $10^7$ – $10^8$  protons per pulse. This very high current proton beam will be accelerated in a laser ultrathin-foil interaction, and transported by a beam line consisting of quadrupole and analysing magnets. This ensures good beam qualities such as energy spread, charge, repeatability and availability of different energies, which means that for the first time laser acceleration becomes a real laser accelerator. With the development of high repetition-rate petawatt (PW) laser technology, we can now envision a compact therapeutic machine for cancer treatment in the near future.

## INTRODUCTION

Beam acceleration driven by laser plasma interaction was proposed by Tajima in 1979 [1]. There is no breakdown problem since the accelerating field is set up in a plasma. This new acceleration method can produce 100 GV/m accelerating gradient, which is three orders of magnitude higher than the accelerating gradient produced by a conventional RF accelerator. Many laboratories in the world carry out research on laser plasma acceleration, since it has a promising future. In 2014, a 4.2 GeV quasi-monoenergetic electron beam was obtained at LBNL, using a 300 TW laser and capillary tube [2]. A 93 MeV proton beam has been obtained using the radiation pressure

acceleration method with a circularly polarized petawatt laser pulse [3]. Although the energy of a laser-driven beam can meet the requirements for many applications, the instability and wide energy spread limit the prospects. Many efforts have been made to obtain monoenergetic and stable beams in various labs. Quasi-monoenergetic electron beams were generated by three teams in 2004 [4–6]. Laser-driven proton beam acceleration combined with a conventional beam line is a useful method to realize a monoenergetic proton beam [7–8]. However, until now, most of the beam lines for laser-driven proton acceleration are in the design stage. The beam line for CLAPA has been built, and some proton beam experiments have been completed. An energystable beam with a 1% energy spread has been observed. This paper will introduce the beam line design and experiment results.

## BEAM LINE DESIGN

Beams generated by laser-driven acceleration have high peak current, large divergence and wide energy spread. According to these characteristics, three functional sections are designed for the beam line, namely a collecting section, an energy analysis section, and a beam shaping section. The beam line layout of CLAPA is shown in Fig.1.

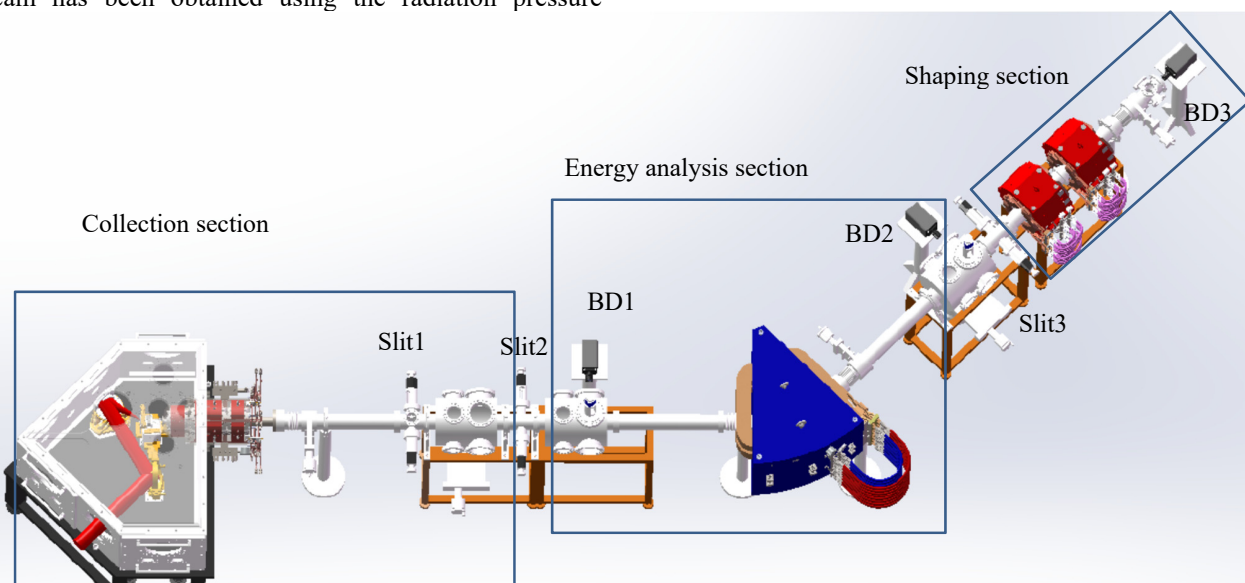

Figure 1: Beam line layout of CLAPA.

\* Work supported by National Grand Instrument Project 2012YQ030142

<sup>†</sup> zhukun@pku.edu.cn, lc0812@pku.edu.cn

### Collection Section

A proton beam generated by laser-driven acceleration can be collected by a superconducting solenoid or a quadrupole magnet [9-10]. Compared with a superconducting solenoid, the advantages of a quadrupole are its simple structure and low cost. So a compact triplet of magnets is used to collect the protons in our case. In order to collect as many protons as possible, the triplet is set into the target chamber, close to the target. An aperture is installed in front of the triplet lens to remove particles with large divergence. The designed maximum acceptable angle of divergence is 50 mrad. The triplet is installed in the shell as a whole unit with maximum diameter of 320 mm. Figure 2 shows the 3D model of the triplet. It has a high field gradient.

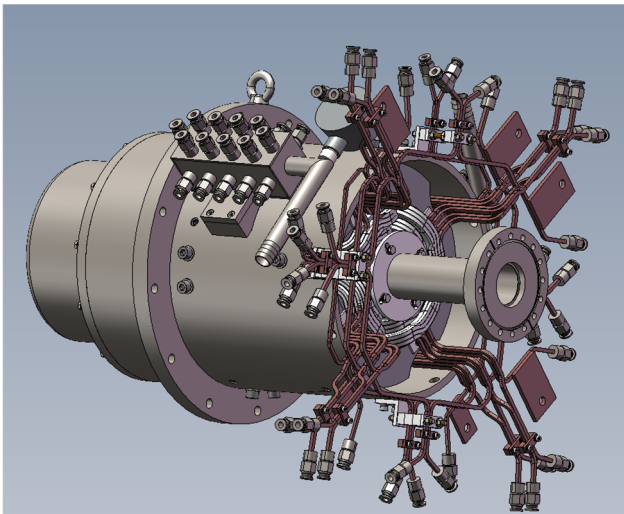

Figure 2: 3D model of quadrupole triplet.

The triplet lens can focus the beam in both  $x$  and  $y$  directions. The beam envelope in the  $x$  direction is less than 2 mm at the slit, which is the entrance of the energy analysis section. The beam envelope in the  $y$  direction is decreased slowly, to achieve a small envelope in the gap of the dipole magnet.

### Energy Analysis Section

The point-to-point transport method is used in the energy analysis section. The  $45^\circ$  bend magnet's radius is 650 mm. The maximum field is 1.5 T and the gap is 50 mm. Because the beam envelope in the  $y$  direction is small enough, the

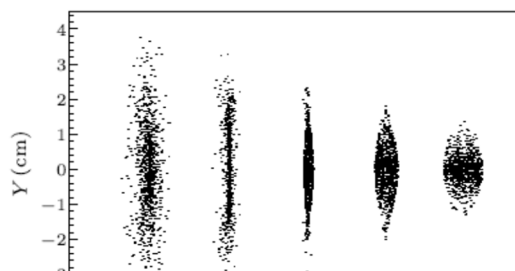

Figure 3: Different energy beams separated in the  $x$  direction. From left to right, beam energy is +2%, +1%, 15 MeV, -1%, -2%.

bend magnet is designed without an edge angle for focusing in the  $y$  direction. The object and image points are both 1575 mm from the bend magnet. The injected proton beam is focused to form a beam waist at the object point of the bend magnet, where a slit is installed to selectively exclude particles with large energy straggling. The beam is analysed by the bend magnet and forms a beam waist at image point in the  $x$  direction, where an adjustable slit is installed to select a proton beam with a particular energy spread. The beam energy spread which is adjusted by the slit width is variable from 1%–5%. Figure 3 shows the simulation result with beams of different energy separated by the bend magnet at the image point. The energy resolution is better than 1%, according to the simulation results.

### Beam Shaping Section

The beam shaping section is composed of two quadrupole magnets each with a 100 mm aperture, located 200 mm downstream from the image point. This doublet magnet can control the beam spot size on the sample at the experiment terminal.

### Beam Line Simulation Result

The whole beam line has been simulated using the TRACK code, and the result with 1% energy spread is shown in Fig. 4. The transport efficiency is 100%. If a beam with 5% energy spread is delivered, the efficiency is 92%. Some protons are lost on the wall of the vacuum pipe at the position of the quadrupole doublet in the shaping section.

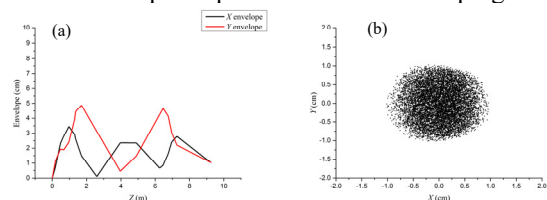

Figure 4: (a) Proton beam envelope with 1% energy spread; (b) Distribution of proton beam at the target.

## BEAM EXPERIMENT RESULT

The beam line was set up at the end of 2016. Firstly, the collection section was set up and an energy spectrometer installed at the end to collect experimental data for laser-irradiation of a solid target. The parameters of the quadrupole triplet were set to different values to transport beams with different energies. The energy spectrum was measured with an MCP installed in the energy spectrometer (see Fig. 5). The number of protons at a specific energy is increased greatly by setting the proper parameter values for the quadrupoles. By the quadrupoles' focusing, the number of protons increase 7 times for a 3 MeV beam, 20 times for 4 MeV and 20 times for 5 MeV (as shown in Fig. 5). The key parameters for the experiment

are optimized by these experimental results, such as the laser spot size, target material and thickness, etc.

In the second stage, the bend magnet, quadrupole magnet and the experiment terminal were installed and the energy analysis ability of the beam line was tested. The proton beam signal was observed on the scintillator via an EMCCD, which is installed 200 mm before the image point. The experimental result fits well with the simulation result, as shown in Fig. 6.

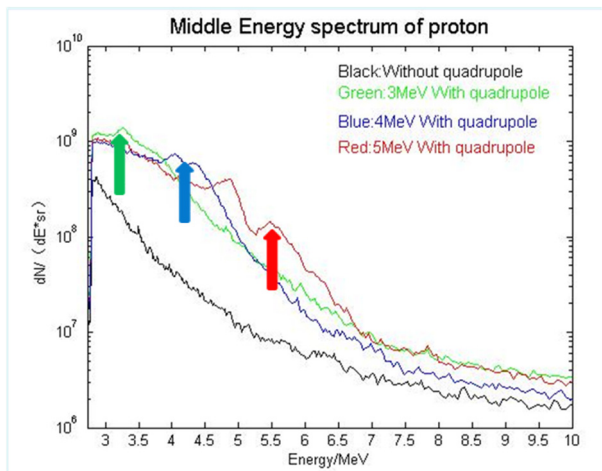

Figure 6: Energy spectrum of the proton beam focused by the quadrupole triplet.

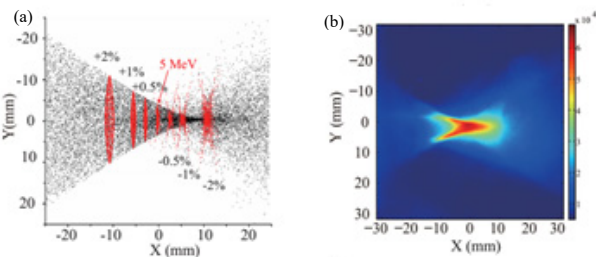

Figure 7: Proton beam profile (a) simulation result; (b) beam signal on scintillator.

After the proton beam was selected by the slit and shaped by the quadrupole doublet, a monoenergetic beam was observed at the beam dump location BD3. The energy spread is adjustable by changing the width of the slit, and the cut-off energy method is used to verify the accuracy of energy. A series of different beams with 1% energy spread was obtained on the scintillator by controlling parameters of magnets, as shown in Fig. 7.

## CONCLUSION

The beam line of CLAPA, which has collection, energy analysis and shaping functions, has been designed and installed. A beam with energy from 1–10 MeV and energy spread of 1% was obtained at the experiment terminal. The

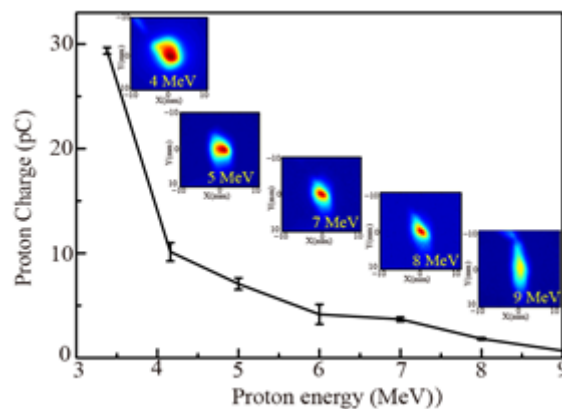

Figure 5: beam signal on scintillator with different central energies.

beam line greatly improves the quality and stability of the proton beam. The high quality beam generated by CLAPA could be used in many applications.

## REFERENCES

- [1] T Tajima and J Dawson, “Laser electron accelerator”, *Physical Review Letters* 43, 267–270, 1979.
- [2] W P Leemans *et al.*, “Multi-GeV electron beams from capillary discharge guided subpetawatt laser pulses in the self-trapping regime”, *Physical Review Letters* 113 (24): 245002, 2014.
- [3] I J Kim *et al.*, “Radiation pressure acceleration of protons to 93MeV with circularly polarized petawatt laser pulses”, *Physics of Plasmas* 23 (7): 056401, 2016.
- [4] C Geddes *et al.*, “High-quality electron beams from a laser wakefield accelerator using plasma-channel guiding”, *Nature* 431 (7008): 538, 2004.
- [5] J Faure *et al.*, “A laser-plasma accelerator producing monoenergetic electron beams”, *Nature* 431 (7001): 541, 2004.
- [6] S P Mangles *et al.*, “Monoenergetic beams of relativistic electrons from intense laser-plasma interactions”, *Nature* 431 (7008): 535, 2004.
- [7] M Nishiuchi *et al.*, “Focusing and spectral enhancement of a repetition-rated, laser-driven, divergent multi-MeV proton beam using permanent quadrupole magnets”, *Applied Physics Letters* 94: 061107, 2009.
- [8] M Schollmeier *et al.*, “Controlled transport and focusing of laser-accelerated protons with miniature magnetic devices”, *Physical Review Letters* 101: 055004, 2008.
- [9] I Hofmann *et al.*, “Collection and focusing of laser accelerated ion beams for therapy applications”, *Physical Review Special Topics: Accelerators and Beams* 14: 031304, 2011.
- [10] D Jahn *et al.* “First application studies at the laser-driven LIGHT beamline: Improving proton beam homogeneity and imaging of a solid target”, *Nuclear Instruments and Methods in Physics Research Section A*, 2018, to be published.