

CONSTRUCTION AND COMMISSIONING OF THE S-BAND HIGH-GRADIENT RF LABORATORY AT IFIC

D. Esperante[†], C. Blanch, M. Boronat, J. Fuster, D. Gonzalez Iglesias, A. Vnuchenko,
IFIC (CSIC-Univ. Valencia), Valencia, Spain
B. Gimeno, Univ. Valencia, Valencia, Spain

N. Catalan Lasheras, G. Mcmonagle, I. Syratchev, W. Wuensch, B. Woolley
CERN, Geneva, Switzerland

A. Faus Golfe, LAL, Univ. Paris-Sud, CNRS/IN2P3, Univ. Paris-Saclay, Orsay, France

Abstract

An S-band High-Gradient (HG) Radio Frequency (RF) laboratory is under construction and commissioning at IFIC. The purpose of the laboratory is to perform investigations of high-gradient phenomena and to develop normal-conducting RF technology, with special focus on RF systems for hadron-therapy. The layout of the facility is derived from the scheme of the Xbox-3 test facility at CERN [1] and uses medium peak-power (7.5 MW) and high repetition rate (400 Hz) klystrons, whose RF output is combined to drive two testing slots to the required power. The design and construction of the various components of the system started in 2016 and has been completed. The installation and commissioning of the laboratory is progressing, with first results expected before mid-2018. The technical characteristics of the different elements of the system and the commissioning status together with preliminary results are described.

INTRODUCTION

High-Gradient (HG) know-how and technology for normal-conducting (or “warm”) accelerating Radio-Frequency (RF) electron linac (linear accelerator) structures recently developed for projects such as NLC/JLC (Next/Japanese Linear Collider) and CLIC (Compact Linear Collider), has enabled an increase in the achievable accelerating gradient from 20-30 MV/m to 100-120 MV/m. This gain has come through a better understanding of the high-power RF vacuum arcs or breakdowns (BD) phenomena, the development of quantitative HG RF design methods and refinements in fabrication techniques.

General interest has been shown over the last years for compact and more affordable facilities for hadron-therapy. The HG technology, although developed for accelerating electrons, can be used for more compact linacs also for protons, which is potentially important in the new trend in hadron therapy of using linacs able to provide protons of 70-230 MeV or light ions of 100-400 MeV/u. High frequency linacs are of particular interest for medical applications [2] because they provide a high degree of flexibility for treatment, such as running at 100-400 Hz pulse rate and pulse-to-pulse beam energy (and intensity) variations. This kind of accelerator is very well suited to treat moving organs

[†] daniel.esperante@ific.uv.es

with 4D multi-painting spot scanning technique [3]. Project studies like TULIP [4] are taking advantage of these developments and pursuing more affordable single room facility medical linacs of reduced size. HG technology can make a significant contribution to reducing the footprint of linacs, but before industrial deployment still many aspects need to be further understood related to the BD phenomena which can result in further significant performance increases.

THE S-BAND TEST FACILITY

The design and construction of the HG RF lab has been developed in collaboration between the IFIC's Group of Accelerator Physics (GAP) and the CLIC RF group. The layout is inspired by the scheme of the Xbox-3 test facility at 12 GHz, which is currently running at CERN, but a central frequency of 2.9985 GHz. It will permit the conditioning and testing of two S-band structures simultaneously.

High Power RF and Waveguide Network

On a first stage, the test facility has been designed to combine two 7.5 MW S-band (2.9985 GHz) klystrons through a 3 dB hybrid and feed simultaneously two test slots. The relative phase of the klystrons RF output can be changed every pulse to direct the power to any of the two branches. With the nominal repetition rate of 400 Hz, the test facility will be capable of performing the conditioning of two structures at 200 Hz simultaneously or one structure at 400 Hz. Figure 1 shows the scheme of the high-power components and the waveguide network.

In a first step, the Low-Level RF (LLRF), based on a ‘National Instruments’ PXI system, generates a low power (~0 dBm) 2.9985 GHz and 5 μ s length pulsed RF signal. The RF is preamplified 56 dB in a 400 W solid state amplifier (model AM10-3S-55-55R from ‘Microwave Amplifiers’) to feed the klystrons. The two klystrons are capable of providing a maximum RF peak power of 7.5 MW for an RF pulse length of up to 5 μ s. The tubes are a VKS8262G1 model built by ‘CPI’. The output power of both klystrons is combined in a 3 dB hybrid to sum up to 15 MW in each line, depending on the relative phase between the two incoming RF waves. The power is sent through waveguides (WR-284) to the devices under test (DUT) with an RF load at the output to terminate the waveguide network. Directional couplers, pumping ports and vacuum gates complete the network, together with the experimental setup required for BD studies, as shown in Fig. 1.

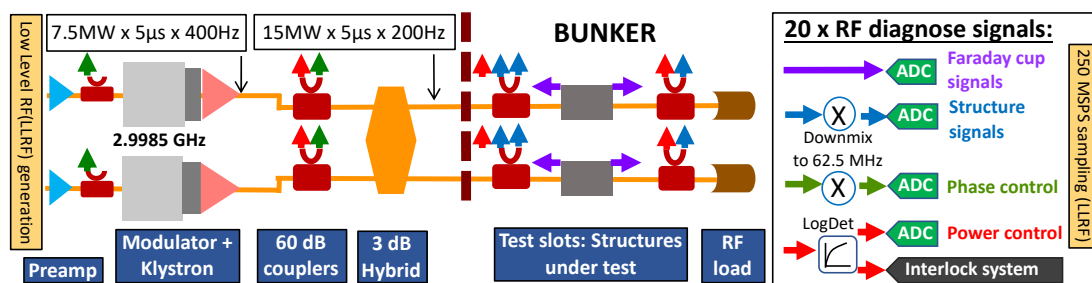

Figure 1: First stage layout of the high-power system of the IFIC HG RF laboratory.

The RF power amplitude of each klystron can be adapted pulse to pulse, offering the required flexibility to be able to test several prototype designs or structures on different conditioning states. This requires a continuous monitoring of the phase and amplitude of the RF signal on several points of the waveguide network through directional couplers. The optimization of the repetition rate and peak power implies important reductions of the time necessary to perform a conditioning and test the structures.

LLRF and Diagnostic Setup

The PXI system manages the LLRF generation, the acquisition of signals for diagnostics, the processing, the trigger control and interlock of the hardware. The PXI RF generators provide the modulated RF pulse (amplitude and phase) which drive the solid-state preamplifiers, which in turn feed the klystrons. The forward and reflected RF signals are diagnosed in several stages of the waveguide network to optimize the pulse modulation, but also to protect the system from an unexpected rise of the reflected signals, using directional couplers. These RF signals are down-mixed to 62.5 MHz before being digitized at 250 MSPS (4 samples per RF period) on the PXI ADC and FPGA modules, which carry out a real-time IQ demodulation and the data processing needed for BD detection. Some signals are also used to perform a reliable closed loop control of the input power to the structure and of the signals' phase.

The reflected power from the structure towards the klystron, caused by the BDs, requires a robust interlock system in order to avoid damage the components due to an excessive high reflection signal over many pulses. The reflected signals are processed using RF logarithmic detectors. Due to their large dynamic range the log detectors are suitable to perform fast detection of these signals which is required for a fast interlock system.

Finally, Faraday cups placed in the upstream and downstream directions along the structure's beam axis, will be used to measure dark currents produced on the structure under test, as shown in Fig. 2.

INTEGRATION AND COMMISSIONING

The integration of the system in the lab (shown in Fig. 3) and commissioning process are still ongoing. All the LLRF elements have been ordered or built and characterized. The majority of high-power RF system components have been tested and characterized. The waveguide network parts, such directional couplers, pumping ports and hybrid have

been measured with a Vector Network Analyser prior to installation in order to verify the required characteristics and obtain the right coupling and reflection values at the working frequency. These measurements, together with the insertion losses from all the elements of the RF network, are essential to have an accurate estimate of the power delivered and reflected from the DUTs.

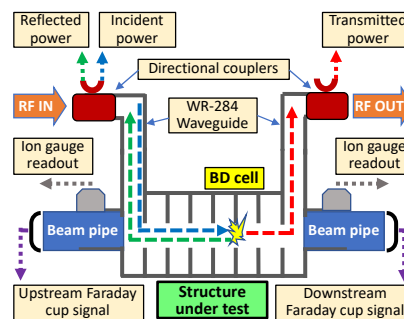

Figure 2: Layout of the device under test and the diagnostic systems. The arrows show the signals read out by the acquisition system.

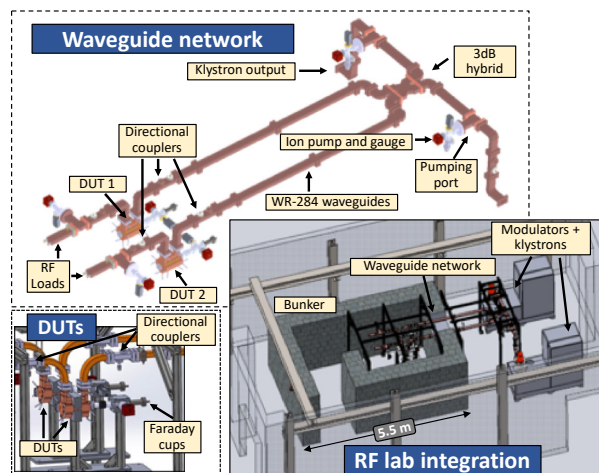
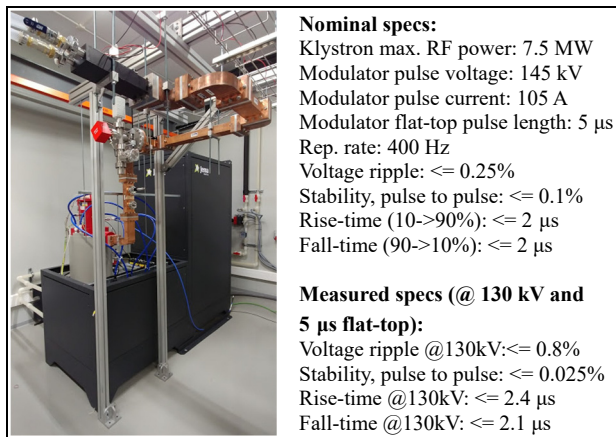

Figure 3: 3D of the high-power RF network of the IFIC HG RF laboratory and integration in the laboratory.

One modulator and klystron and a first part of the waveguide network have been installed, together with the associated vacuum and cooling system. The klystrons are powered with solid-state modulators made by 'JEMA Energy', which provide a maximum cathode voltage and current to the klystron of 145 kV and 105 A, expecting a peak output RF power of 7.5 MW (Fig. 4) and maximum efficiency of ~49%.



Nominal specs:
 Klystron max. RF power: 7.5 MW
 Modulator pulse voltage: 145 kV
 Modulator pulse current: 105 A
 Modulator flat-top pulse length: 5 μ s
 Rep. rate: 400 Hz
 Voltage ripple: \leq 0.25%
 Stability, pulse to pulse: \leq 0.1%
 Rise-time (10->90%): \leq 2 μ s
 Fall-time (90->10%): \leq 2 μ s

Measured specs (@ 130 kV and 5 μ s flat-top):
 Voltage ripple @130kV: \leq 0.8%
 Stability, pulse to pulse: \leq 0.025%
 Rise-time @130kV: \leq 2.4 μ s
 Fall-time @130kV: \leq 2.1 μ s

Figure 4: First modulator, klystron and waveguide network on the IFIC laboratory.

First integration tests have been performed at the IFIC laboratory. Tests over the modulator proved a good performance in terms of very good voltage pulse to pulse stability ($<0.025\%$) and high pulse flatness ($<1\%$). The flatness and stability are defined as relative measurements over the cathode voltage. The flatness is measured as the cathode peak to peak voltage during a pulse flat-top of 5 μ s, while the stability is the sigma of average cathode voltage during 900 acquisitions over the pulse flat-top. Figure 5 shows the first preliminary measurements of stability and ripple for several voltages at the klystron cathode. The flatness is out of specs due to ripple in the pulse shape, which is not limiting for the purpose of the laboratory. One can observe that stability and flatness decrease with higher voltages since the magnitudes measured keep quite constant independently of the cathode voltage. Figure 6 shows a typical pulse shape of the cathode voltage and current in diode mode.

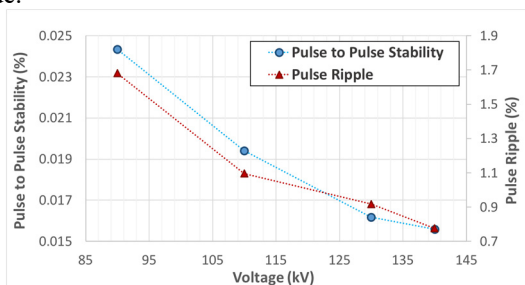

Figure 5: Pulse to pulse stability and pulse ripple.

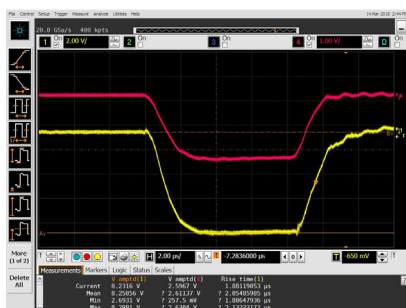

Figure 6: Modulator voltage and current pulse flatness at 100 kV and 7.5 μ s (include rise and fall time) at the klystron cathode.

As for the klystron, the perveance parameter has been evaluated using several input cathode voltages. The results are shown in Fig. 7, which proves the uniformity of the klystron perveance in the full range of input voltages.

Finally, first measurements with RF have been performed with the modulator+klystron unit. Short RF pulses of 0.25 to 1 μ s have been injected in the klystron at 90 kV and 110 kV, for different input power levels, at a low rate of 5 Hz and a modulator flat-top of 5 μ s. At 90 kV, the klystron saturation point could be reached for ~ 55 dBm input power (see Fig. 8), while for 110 kV the saturation could not be achieved yet due to outgassing on the waveguide network. A conditioning process with RF pulses is ongoing such that the klystron and modulator can be pushed to the limit in the upcoming time.

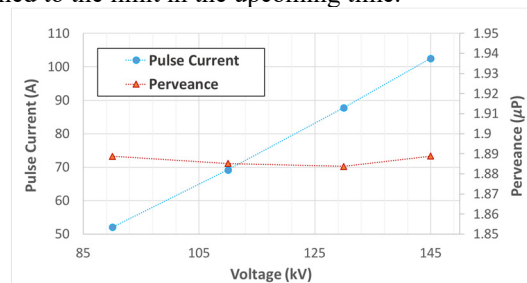

Figure 7: Klystron current and perveance vs. voltage.

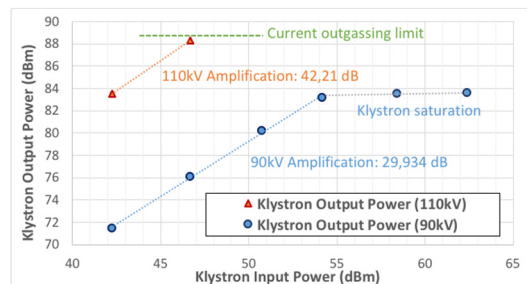

Figure 8: Klystron output power.

CONCLUSION

HG RF technology offers the possibility of constructing very compact linear accelerators destined for different applications. However, the performance of HG linacs is limited by the occurrences of vacuum arcs. The IFIC HG-RF test facility which is currently under commissioning is intended to support the development of a wide experimental programme of testing HG accelerating structures and breakdown phenomenology studies for S-band HG linacs.

ACKNOWLEDGEMENTS

We would like to thank the RF CLIC group at CERN for their help and continued support.

This project has received funding from the European Union's Horizon 2020 research and innovation programme under the Marie Skłodowska-Curie Grant Agreements No. 750871 and No. 675265, European Regional Development Funds REDEF FICTS2013-03 and from KE 2638/BE Agreement between IFIC-CSIC and CERN.

REFERENCES

- [1] N. Catalan Lasheras *et al.*, “Commissioning of Xbox3: a very high capacity X-band RF test stand”, *Proc. LINAC’16*, East Lansing, USA, Sep. 2016, pp. 568-570. doi:10.18429/jacow-linac2016-tup1r047
- [2] U. Amaldi, S. Braccini, and P. Puggioni, High Frequency Linacs for Hadron Therapy, *Rev. Accel. Sci. Tech.* 02, 2009, p. 111.
- [3] C. Bert *et al.*, Target motion tracking with a scanned particle beam, *Med. Phys.* 34 (12), 2007, p. 4768.
- [4] S. Benedetti, A. Grudiev, and A. Latina, High gradient linac for proton therapy, *Phys. Rev. Accel. Beams* 20, 040101 – Published April 2017.

Content from this work may be used under the terms of the CC BY 3.0 licence (© 2018). Any distribution of this work must maintain attribution to the author(s), title of the work, publisher, and DOI.