

A Fast Magnet Current Change Monitor for Machine Protection in HERA and the LHC

M.Werner¹, M.Zerlauth², R.Schmidt², V.Kain², B.Goddard²
¹DESY, Hamburg, Germany, ²CERN, Geneva, Switzerland

ABSTRACT

Fast Magnet Current Change Monitors (FMCM) have been designed to provide a reliable trigger signal for dumping the beam(s) in case of powering failures of magnets with fast effects on the particles. Rather than relying on current measurements that can be imprecise and affected by noise, the voltage drop over the circuit is measured and the magnetic field in the magnets is derived in real time, based on an impedance model of the electrical circuit. Developed at DESY for the HERA storage ring to protect the superconducting magnets in case of sudden power supply failures, the system has been recently validated for its use in critical circuits of the LHC and its transfer lines. The benefits of the system and the experience at DESY and CERN are discussed and presented along with results of the tests performed. The system will be integrated into the CERN accelerator controls structure and provide additional protection for operation with high intensity beams in the LHC and its injector from 2006 onwards.

HISTORY AND MOTIVATION AT DESY AND CERN

For DESY, it turned out that, in case of failures of power converters for some critical quadrupole magnets, the beam was not dumped in time to avoid a possible damage of detector components. The beam loss monitors were too slow, and the internal power converter monitoring did not cover all failure cases, especially not the failures in the current control loop. Driven by beam incidents in 2003, the internal alarm reaction time of the power converters was improved and FMCMs were developed and installed for 14 critical magnet circuits in 2004.

For CERN, during several session of the Chamonix XIV conference [1] and the Machine Protection Review [2] „Fast Current Change Monitors“ were proposed for additional protection, based on the system already operational at DESY. A beam incident in the TT40 extraction line of the SPS (destroying several vacuum chambers and a quadrupole magnet) showed the necessity of an additional protective device [3]. Tests with an FMCM developed for HERA showed that even an unchanged device would fully cover the CERN needs with respect to sensitivity and speed and a collaboration has started between DESY and CERN to adapt the system to CERN requirements.

POWER CONVERTER FAILURE SCENARIOS

After a power converter failure feeding a quadrupole magnet in a circular machine with current, the following happens: up to a certain magnet current deviation, the beam orbit will only slightly deviate, depending on the distance of the beam orbit from the quadrupole centre. After reaching a certain limit, the beam will suddenly blow up within only a few turns. With very fast beam loss monitors such failures can be captured for most cases, but in any case only after the beginning of the beam loss.

For a dipole magnet in a circular machine, the beam will change its orbit proportional to the current deviation and after some time hit the vacuum chamber. Again, fast beam loss monitors could capture such failures only once beam losses occur.

For a dipole magnet in a transfer line, there is no circulating beam which could trigger a beam loss monitor. For a wrong magnet current, the full beam will be lost in the chamber without warning. Magnet current or field monitoring before and during an extraction is the only way to prevent damage.

OPERATING MODES

The FMCM can be used for two operating modes: circulating beam mode (for HERA and LHC) and pulsed beam mode (for transfer lines used for extraction from the SPS towards LHC and CNGS).

Circulating beam mode is used to protect a machine with circulating beam. Magnets are in general ramped very slowly (typically within several minutes). A triggering of the FMCM will dump the beam(s). False triggers are very annoying because machine operation will be interrupted for several hours in case of the LHC. The frequency of false triggers must not be higher than once per several

months for every FMCM device. Critical for this circulating beam mode is the correct setting of the thresholds.

Pulsed beam mode is used to protect a transfer line if a bunch train is to be transferred from one accelerator to another. A triggering of the FMCM will inhibit the extraction. Magnets can be ramped very rapidly (typically within seconds) because they have to provide their nominal field only during the beam transfer and will be switched off in the remaining time to save power and minimize the heat load. False triggers, even as frequently as once per hour for every device, are uncritical as a false trigger just inhibits the current beam transfer and already after a delay of a few seconds the next try to transfer the beam can take place if all conditions are met. Critical for this pulsed beam mode is the correct behaviour in time: the FMCM must be ready to detect small current changes on the flat top a short time after a fast current ramp (when ramping the magnet to the flat top) occurred. The internal time constants of the device are chosen differently in this case.

COMBINATION WITH OTHER PROTECTION DEVICES

The main advantage of the FMCM is its sensitivity and speed, but it cannot detect slow current changes (in the range of 100ms or more for circulating beam mode, in the range of 20ms or more for the pulsed beam mode) or static current deviations. So it must be combined with other protection devices.

In the HERA case, the existing beam loss monitors with a reaction time of approx. 5ms are adequate.

For LHC the beam loss monitors serve the same purpose, even being fast enough to react in time on the beam losses caused by fast magnet current deviations.

For the SPS transfer lines, a monitor system inside the power converters verifies the absolute magnet current every 5ms, thus detecting slow changes of the absolute current value in time.

For most power converter failures, alarm logic internal to the power converter detects the failure before the current changes. If these alarms are used to inhibit or dump the beam additional redundancy is provided. It is important that these alarms are not delayed by the use of relays, filters or digital processors so that they can act on the beam in time.

Depending on the failure case, the discussed FMCM can provide redundancy and / or increased speed for an existing protection system.

REQUIREMENTS (PRECISION, SPEED) FOR HERA AND LHC

The FMCM was originally developed for HERA, where moderate demands were specified: the device should detect a fast current change of 0.5% of the full scale value within 1ms. Tests at CERN with an LHC dipole and an extraction septum showed that the existing system even met the tight specifications of the CERN applications. Moreover, experience at HERA during several months showed no false triggering even using a threshold of 0.03% for some devices.

	Tolerance [%]	Reaction time [ms]
Hera	0.5	0.5
SPS extraction	0.1	0.05
LHC	0.03	0.7

Table 1: Most critical magnet current tolerances and reaction times at DESY and CERN

FMCM TESTS AT CERN

At CERN, tests for both operating modes of the FMCM were performed using a HERA type FMCM: for “circulating beam mode” with a real LHC dipole, for “pulsed beam mode” with a real septum magnet. The tests showed the following results:

- The inherent delay of the device (from the magnet current deviation crossing the threshold until the creation of an alarm at the output) was approximately 30us.
- The tightest possible threshold for the circulating beam mode was determined by the ripple of the power converters, not by electronics or environmental noise. The internal FMCM noise is thus not the limitation for the sensitivity.

- For “pulsed beam mode” the possible threshold is limited by the temperature rise of the magnet (in case of e.g. the SPS extraction septum magnets) resulting in a rise of the ohmic resistance and thus resulting in a voltage rise for constant current. Fortunately, these temperature effects are small enough to maintain the desired threshold without further effort. The tests have proven that all CERN requirements can be met by the FMCM.

FMCM OPERATION AT CERN

For critical LHC dipoles, 6 devices configured for “circular beam mode“ will be installed for LHC operation in 2007. The FMCMs will be connected to the LHC beam interlock system to remove the beam in time. For the LHC, the FMCM is a redundant protection system as the beam loss monitors installed in the LHC are designed to be fast enough to avoid damage even for fast beam losses. However, the FMCM will provide further protection of accelerator equipment as it will detect the failure and remove the beam(s) even before beam losses occur.

For critical dipoles in the transfer lines, 14 devices configured for “pulsed beam mode” will be installed. The FMCM alarm outputs are connected to the SPS extraction interlock system. As explained earlier, a beam loss system cannot provide protection for beam transfers, thus making the FMCM the only device to assure the protection of equipment in the transfer lines along with the internal power converter alarm.

WORKING PRINCIPLE

The basic idea of the FMCM [4], [5] is the connection of the magnet voltage to a low-pass filter, followed by a high-pass filter. The result is discriminated by a window comparator (see also Figure 1). The low-pass reduces high frequency noise at the input created by electronic noise, electromagnetic interference or power spikes. In addition, it compensates the increased high frequency response of the magnet voltage to the magnetic field. This increased high frequency response originates from the fact that the inductive part of the magnet voltage is, in the mathematical sense, the differentiation of the magnetic field, and differentiation corresponds to a linear increase of signal amplification with rising frequency. As a result, the response of the whole system (magnet and low-pass) is constant over the whole frequency range while high frequency noise and voltage spikes are suppressed significantly. The high-pass filter removes the DC part of the signal in order to detect and amplify changes of the magnet current and to make this detection independent of the DC level of the signal. The window comparator (triggering if the absolute value of the signal after the high-pass exceeds a certain threshold) generates the output alarm signal which is then used to dump the beam in a circular machine or to inhibit extraction into a transfer line.

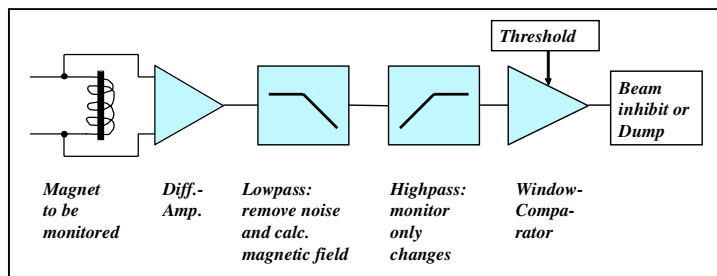

Figure 1: Working principle of the FMCM

EXTENDED FUNCTIONALITY

The FMCM is equipped with additional features in order to facilitate commissioning and operation of the device, to test functions, to read back values and to retrieve post mortem information in case of a beam dump. Figure 2 illustrates the following explanations: An RS422 serial communication will be implemented for remote control of the device beside the existing local control. The “Min/Max-memory” will calculate the maximum error signal for an extended time, giving a lower limit for the alarm threshold to ease commissioning. The “pre-alarm” feature (not shown in the figure) is implemented by using a second window comparator with another threshold controlling a LED on the

front panel and a status bit for remote readout. This pre-alarm can draw attention to a power converter with increased noise possibly announcing a future failure. The “post mortem” feature records the measured and simulated signals shortly before and after a triggering of the device, including timestamps with a time base synchronized to the CERN timing system. Digital signal processing is possible due to the presence of an FPGA, although only analogue signal processing is currently used in the path for the beam dump or extraction inhibit generation.

THE FMCM IN ITS ENVIRONMENT

The maximum magnet voltage (varying between 60V and 3600V depending on the circuit type) is scaled down to 10V by a resistive voltage divider. The resulting voltage is connected to an isolation amplifier to avoid ground loops. Voltage divider and isolation amplifier should be close to the terminals where the magnet voltage is taken from, which is either at the level of the power converter or the magnet terminals. The isolation amplifier is connected to the FMCM, also providing the supply of the isolation amplifier. An additional signal (0-10V) from a DCCT monitoring the magnet current can be connected to the FMCM for inclusion in the post mortem recording.

The alarm output is connected to the machine protection system (BICI-Box of the beam interlock system), to request the beam dump or injection inhibit.

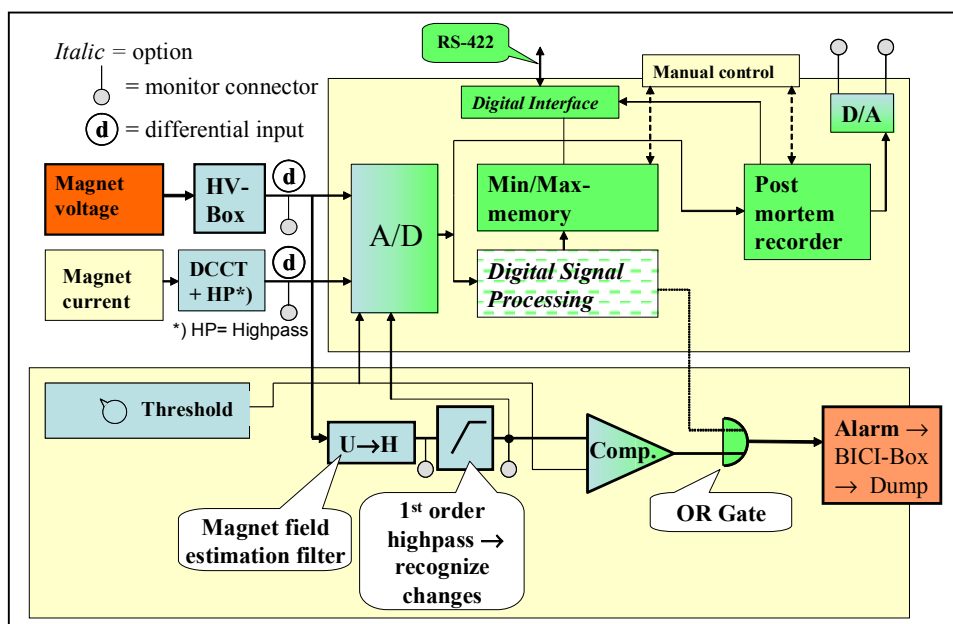

Figure 2: Block diagram of FMCM in its environment: yellow shaded boxes are inside the FMCM.

TESTS: COMPARISON WITH OTHER DETECTION PRINCIPLES

Previous tests have been performed at CERN based on DCCTs measuring the magnet current or hall probes near a magnet lead. For DCCTs and hall probes, high frequency noise, as a matter of principle, cannot be suppressed without degrading the reaction speed and the tests showed that it would be critical to reach the tight thresholds demanded by CERN. Similar tests at DESY using the DCCT output signal have equally proven the signal to be too noisy to derive a dump signal.

Another method is the direct monitoring of the changing magnet voltage. The drawback of this method is that high frequencies are overvalued. Short transients on the magnet voltage would trigger the unit although these transients would not lead to a significant change of magnet current, and it is difficult to separate the ripple of the power converter from real current deviations. Only the FMCM method combines robustness against short transients with high sensitivity and speed. Figure 3 shows a noise comparison between the output signals of a DCCT, a hall probe and an FMCM.

The data sheet of hall probes or DCCTs show an RMS noise of 10^{-4} or even below 10^{-5} of full scale. Compared with the necessary thresholds of $3 \cdot 10^{-4}$, an implementation by using these elements seems possible at first sight. But looking on peak values, they mostly turn out to be much higher than RMS values (looking on a measuring time of some hours), and the noisy environment of power

converters caused by electromagnetic interference and power spikes will increase the noise level further. Experience shows that it is difficult to guarantee that a threshold of $3 \cdot 10^{-4}$ is not violated during normal operation. Keep in mind that in the case of HERA and LHC, every single threshold violation will dump the beam and cause a very unwanted and expensive service interruption in the range of hours.

To illustrate the difference, Figure 3 shows an oscillogram after switching off a magnet being powered with 80A (representing 10% of its nominal current value). The traces for DCCT, hall probe and FMCM output are scaled to approximately the same negative slope after the switch off. The flattening of the curves (approaching the zero slope at the right border) is caused by the AC coupling of the oscilloscope. Note that one vertical division corresponds to approx. 12% of the nominal value for the magnet voltage and to approx. 0.1% of the nominal value for DCCT, Hall probe and calculated magnetic field signal. It is obvious that the FMCM calculated signal is best suited to generate an interlock signal. Filtering could reduce the noise of the DCCT or hall probe signal, but only with the drawback of an additional delay of the alarm signal.

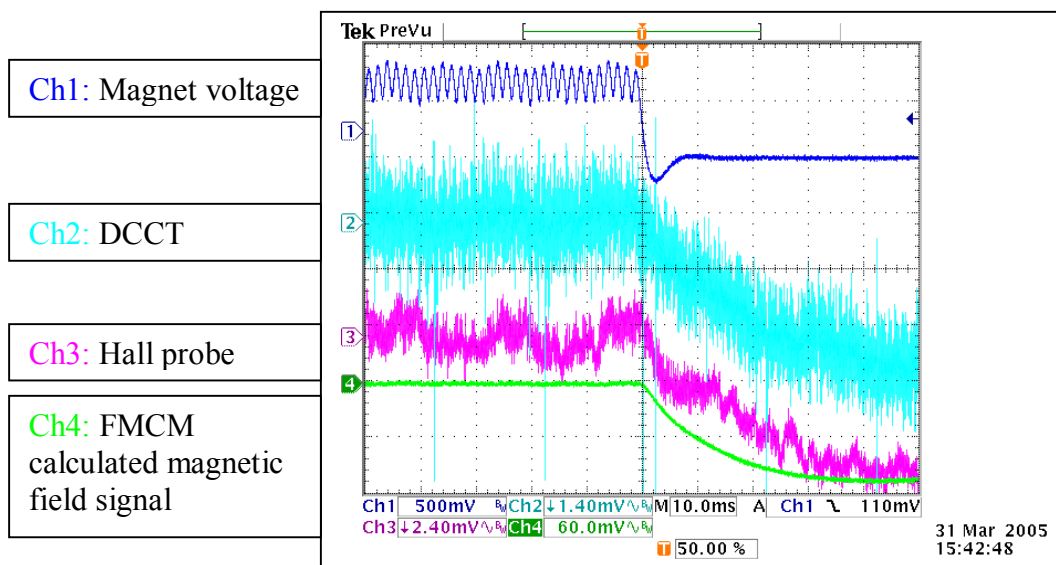

Figure 3: Noise comparison for different magnet monitors

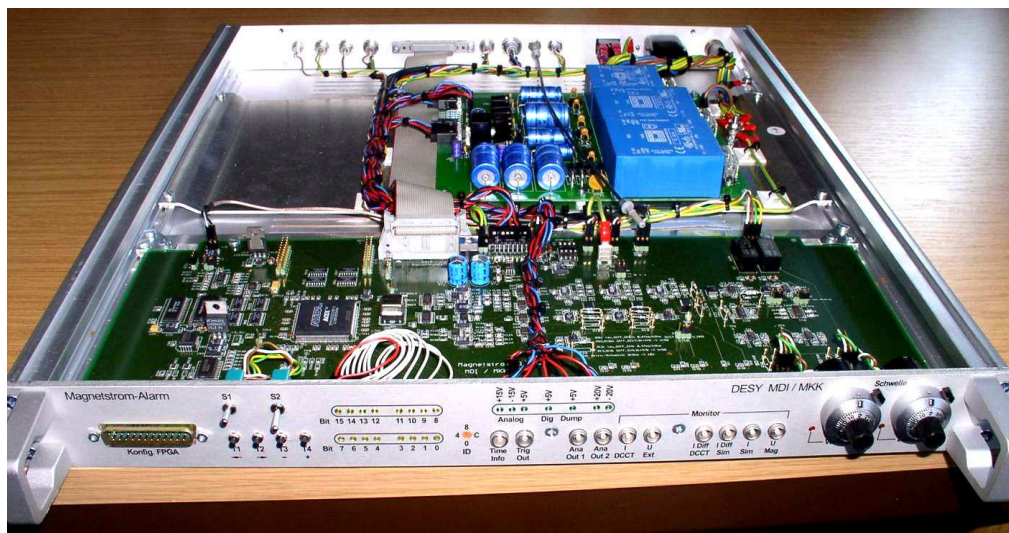

Figure 4: Picture of the FMCM (DESY version)

NUMBER OF FMCMS TO BE INSTALLED AT CERN AND DESY

Planned installation at CERN	Number of FMCMS	Present Installations at DESY	Number of FMCMS
LHC dipoles	6	HERA quadrupoles	14
LHC quadrupoles	4 to 10		
Magnets in SPS-LHC/CNGS extraction lines	14		

EXPERIENCE WITH FMCMS IN HERA

In HERA, 14 FMCMS were installed and commissioned 5 months ago, and up to now, no false trigger has been observed, although the alarm thresholds were set much tighter than required.

The pre-alarm function showed the increased ripple of a defective power converter well before the breakdown of the device. As shown in Figure 5 (Post Mortem Readout of an FMCM in HERA), a beginning power converter oscillation was correctly detected by the FMCM and the beam was dumped in time. The oscillogram was obtained by connecting an oscilloscope to the analogue output of the FMCM configured as output of the internal post mortem memory. The dark blue line shows the magnet voltage, the light blue line represents the calculated magnetic field deviation. The purple line represents the time when the FMCM triggered due to an exceeded threshold. The threshold was set to approx. 0.03% of the nominal magnet current.

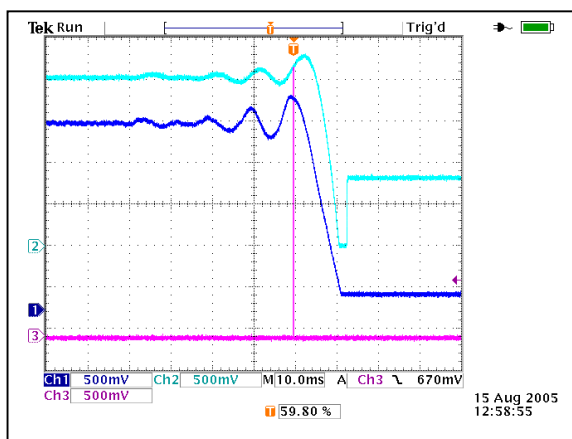

Figure 5: Oscillations of a power converter causing a beam dump at HERA

CONCLUSIONS

Tests have shown that FMCMS are well suited to protect the HERA and LHC accelerators from beam incidents following powering failures of critical electrical circuits. The collaboration between DESY and CERN is well progressing to provide a system adapted to CERN requirements in time for operation with high intensity beams in the LHC and its transfer lines [6] [7].

REFERENCES

- [1] V.Kain: "Safe Injection into the LHC", Chamonix XIV, Geneva, Switzerland
- [2] M.Zerlauth: "Magnet Powering System and Beam Dump Requests", Machine Protection Review, April 2005, CERN, Switzerland
- [3] B.Goddard et al: "TT40 Damage during 2004 High Intensity SPS Extraction", AB-Note-2005-014
- [4] M.Werner: FMCMS Presentation "Hera_Protection_1.ppt", page 13 to 22, HERA-Seminar, Grömitz, Germany
- [5] M.Werner: Patent "Einrichtung zur Bestimmung der Stärke des Magnetfeldes eines Elektromagneten" (Device to determine the magnetic field of an electromagnet), to be achieved, Germany
- [6] M.Werner, M.Zerlauth: 'FMCMS for the LHC and SPS-LHC transfer lines', CERN, DESY
- [7] R.Schmidt: 'Fast Magnet Current Change Monitors', ECR, EDMS Doc.Nr:628602