

ADVANCED HARDWARE TECHNOLOGY IN ALMA BACKEND AND CORRELATOR

F. Biancat Marchet¹, A. Baudry²

¹ *European Southern Observatory, Garching, Germany*

² *Observatoire Aquitain des Sciences de l'Univers de Bordeaux, Bordeaux, France*

ABSTRACT

The Atacama Large Millimeter Array (ALMA) is a single astronomical instrument consisting of up to 64 12m Antennae that can be relocated on more than 200 stations over an area of approximately 15 km across the Llano de Chajnantor plateau at 5000m asl (the Array Operating Site or AOS) in the Chilean Atacama desert.

Originally an equal partnership between Europe and North America, in cooperation with the Republic of Chile, ALMA has been recently extended to include the contribution of Japan that will provide an additional 16-Antenna sub-array (ALMA Compact Array, ACA).

The signal captured by each Antenna (in the range 30-950GHz) is down-converted to a lower Intermediate Frequency (IF), digitized and transferred to the Technical Building, also at the AOS site, as a 120 Gbit/second data stream through one single Optical Fibre.

In the Technical Building a custom processor constituting, with digital filters, the Correlator cross-correlates the signals from all antenna pairs in the array and averages the data flow before passing it to the Computing System for further processing. The IF signal processing and digitizing in the Antenna and the Data Transmission System are part of the ALMA Back End subsystem.

The severe environment requires special attention: at 5000m altitude the heat dissipation capability is greatly reduced, in addition the remote location as well as the lack of oxygen heavily impacts the possibility of performing maintenance on site. This calls for low power dissipation, high reliability and easy maintenance.

Although the most advanced ICT applications are fast approaching the ALMA needs, meeting the ALMA requirements was only possible pushing the technology beyond the state of the art and several Application Specific Integrated Circuits (ASICs) were developed where commercial solutions are not yet available.

This paper aims at providing an overview of the overall ALMA Back End and Correlator subsystems focusing particularly on custom developments.

INTRODUCTION

ALMA Operating Constraints

ALMA is an international astronomy facility. It is an equal partnership between Europe and North America, in cooperation with the Republic of Chile, and it is funded in North America by the U.S. National Science Foundation (NSF) in cooperation with the National Research Council of Canada (NRC), and in Europe by the European Southern Observatory (ESO) and Spain. ALMA construction and operations are led on behalf of North America by the National Radio Astronomy Observatory (NRAO), which is managed by Associated Universities, Inc. (AUI) and on behalf of Europe by ESO.

One peculiar aspect of ALMA is that the antenna Array together with most of the BE equipment as well as the Correlator will be operating at more than 5000m asl. In such remote location the air density is less than 50% the density at sea level severely affecting the cooling capabilities.

Due to the harsh environment no staff is supposed to work permanently on site and reaching it from the base camp (2500m asl, 40km away) will require a considerable amount of time. Furthermore the working conditions, lack of oxygen, extreme temperatures and strong wind, reduce the ability to perform complex or long tasks.

For these reasons, and keeping into consideration the expected 30 years lifetime of the instrument, the maintenance and reliability aspects have been given the largest relevance and had been addressed since the early phases of the design. This aimed at increasing the reliability by reducing the power dissipation and making use of well established technologies, as well as the maintainability implementing the components as much as possible as Line Replaceable Units and finally providing as much extensive remote diagnosis as possible. On the other hand the unprecedented technical requirements could only be met by new and innovative design. A major effort has been therefore

required to find a satisfactory compromise between the need for high reliability and affordable costs on one side and the need for innovation on the other side.

The ALMA Back-End

The Cryogenic Front End (FE) in each Antenna down-converts the received signal (up to 950 GHz in 10 different receivers) and outputs two intermediate frequency (IF) signals per selected receiver, one for each polarization, in the 4-12 GHz bandwidth. The Back-End (BE) further processes those signals to make them suitable for the Correlator and transfers them from the Antenna to the Technical Building (TB) where the Correlator is located. The BE includes equipment both in the Antennae and in the TB that is involved in such signal handling and transmission process.

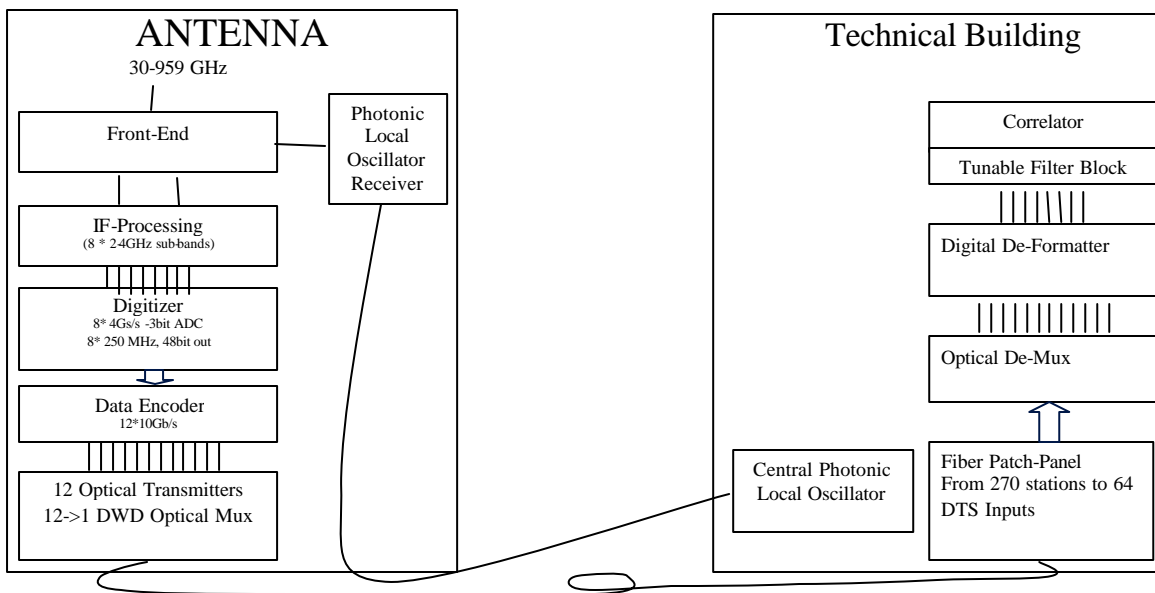

Fig. 1 Antenna and Central Back-End

DATA TRANSMISSION SYSTEM

General Description

The Data Transmission System in the Antenna performs two main tasks: it digitizes the processed IF 'low' frequency signals and converts them in a format suitable for transmission along one single optical fibre. The two 4-12 GHz signals produced by the FE receiver in the antenna are further down-converted by the IF processor to four pairs of 2-4GHz bandwidth signals.

Those signals are digitized (sampled and quantized) at 4Gs/s sampling rate, with 3-bit resolution.

Each 3-bit 4Gs/s data stream is parallelized into a 16-bit parallel word at a rate of 250MHz.

Each pair of these 3-bit 4Gb/s data stream is formatted and multiplexed up to three 10Gb/s (some overhead is added by the communication protocol) serial streams each one driving a laser emitter.

The twelve emitters are tuned to produce a slightly different 'colour' so as to implement a Dense Wavelength Division Modulation (DWDM) which allows the twelve light beams to be mixed together and then injected into one single optical fibre.

At the reception side in the Technical Building the incoming light beam is optically de-multiplexed to separate the 12 original beams, which are converted to electrical signals, de-formatted to restore the original eight 16*3-bit @ 250 MHz data streams and finally recaptured at 125 MHz and fed to the Correlator.

In order to reliably operate at the required light frequency and with the proper power/sensitivity throughout their whole lifetime both the laser emitters and receivers need a sophisticated control system (current/temperature). In the original version this was implemented by discrete electronic boards. Recently the IT market has made available monolithic optical transponders that integrate the complete control system in one single component. In the current design the new components replace the original discrete solution reducing the costs and improving the reliability.

The Digitizer

The heart of the DTS transmitter is the Digitizer chip, “VEGA”, a band-pass 2-4 GHz flash Analog to Digital converter operating at the sampling rate of 4 Gs/s.

Although at present the market offers components that nominally meet some of the requirements, the suitable combination of sampling rate, resolution, maximum input frequency (4GHz) and power consumption is not available, therefore an Application Specific custom device (ASIC) needed to be developed. The low power consumption is a key requirement with respect to the reliability issue: lower dissipation means lower operating temperature which leads to a longer lifetime and hence higher reliability and less maintenance.

The power dissipation is a concern as the low air density at the operating altitude makes the ventilation rather inefficient, especially considering that the digitizer assembly, to reduce RFI, needs to be encapsulated in a sealed case.

VEGA Specifications

In order to meet the high speed and low power requirements, the digitizer uses the Si-Ge technology and BiCMOS 0.25um process. This technology allows the fabrication of high speed and low dissipation hybrid analog/digital devices.

The nominal voltage supply is 2.5V and the average power consumption is 1.5W.

The sampling rate exceeds 4Gsps and an external Sample/Hold is not required thanks to the short aperture time. The output is Gray-coded and the output lines are differential (LVDS).

The device shows a high temporal stability (Allan Variance > 100s), a key requirement for Radio Astronomy. A self-test feature is implemented to allow a simple test of the device enabling an internal low frequency free-run clock.

The chip is packaged in a 44-Pin VFQFPN package (7x7x1mm) which provides a dissipation lead that reduces the thermal resistance between the die and the environment.

A more comprehensive list of specifications and performances can be found in [1].

A synthetic figure of merit combining resolution, speed and power consumption for flash converters is given by the formula:

$$M = 2^N * F/P$$

Where N is the resolution in bits, F is the sampling rate and P is the power.

VEGA shows $M > 21 \text{ GHz/W}$ while similar commercial devices (which anyway do not meet all requirements) have M around 1 GHz/W .

The De-Multiplexr PHOBOS

A companion chip, the de-multiplexer “PHOBOS”, was also developed. It parallelizes an incoming 4Gb/s serial stream in 16-bit words at a rate of 250MHz. One of these devices is connected to each VEGA output line. Despite the higher complexity and similar power dissipation constraints, the development of PHOBOS was less critical being a fully digital device with no analogue parts.

An option considered during the development was the integration in one single chip of both AD conversion and De-multiplexing functions. However, the concern of keeping the analogue part as much separate as possible from the digital part and the complexity of the packaging due to the high pin count (the chip would have $3 * 16 * 2$ outputs) led to two separate devices.

The Development Process

VEGA and PHOBOS are the result of a combined effort between the Observatoire de Bordeaux, the IXL laboratories of the Univeristé de Bordeaux and a commercial partner.

All design, simulations and qualification tests have been performed by the two institutes while the commercial partner provided the software tools and the production facilities.

The development of the devices took several years. A first simplified implementation of the digitizer was designed and produced in 2002 to test the suitability of the technology to meet the requirements.

The first functional 3-bit version, ALTAIR, was developed and tested in 2002.

An improved version, ANTARES, optimizing power consumption and pin-out allocation was produced in 2003. The final fully engineered version, VEGA, including ESD protection, was prototyped in 2004 and mass produced in 2005. Prototyping costs have been kept affordable by making use of the Multiple Project Wafer service provided by the industrial partner where limited

amount of parts can be produced sharing the silicon foundry production costs among several projects/customers and thus reducing the overall NRE.

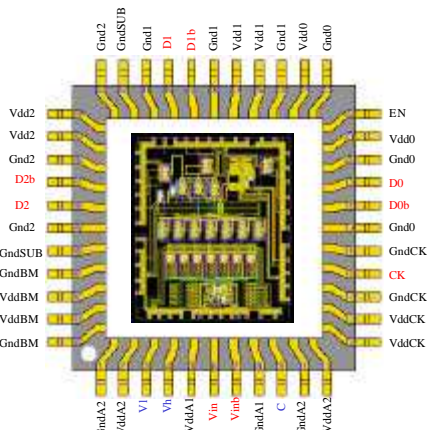

Fig.2 VEGA Photograph and pin-out

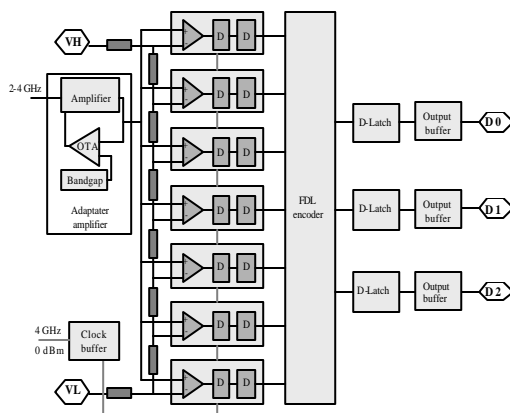

Fig.3 VEGA Functional diagram

PHOTONICS LOCAL OSCILLATOR

To operate the array in interferometric mode the ALMA Front End heterodyne receivers require a phase-stabilized Local Oscillator (LO) coherent among all Antennae to convert the incoming signal to lower frequencies. Receiving frequencies as high as 950GHz and baselines long up to 15km set an extremely tight phase stability requirement for the LO. In order to keep the contribution of the LO low with respect to the atmospheric effects, an overall phase stability of about 50fsec is required for the first LO; this translates to about 17degrees r.m.s phase jitter at the highest array frequency, 950GHz.

To generate and effectively distribute such a stable reference all over the array a photonic approach has been adopted where two laser beams whose frequency difference equals the LO frequency (before multiplication in the front-end –see below) are injected in one single fibre that brings the signal from the Technical Building to the Antenna. At the Antenna the two beams are combined in a photomixer and the resulting electrical signal, whose frequency is the difference of the incoming beams frequency, is fed to the Front End receiver. Inside the Front End this signal, in the range 27-142 GHz, is multiplied up in cryogenic mixers to provide the final high LO frequencies required for the array. The multiplication is needed because the present photomixing technology at ambient temperature can only be effectively used up to around 200GHz.

The laser synthesizer is based on an extremely stable (10^{-10}) master laser to which a second laser, the slave, is phase locked with a frequency difference that is set by a tuneable microwave generator.

The tight requirements in terms of operating frequency and sensitivity of the photomixer are met by a custom device designed and produced at Rutherford Appleton Laboratories (UK), where a modified commercial photodiode has been integrated in a special package providing fibre optic connection, bias connection, filtering and output waveguide.



Fig.4 Photomixer

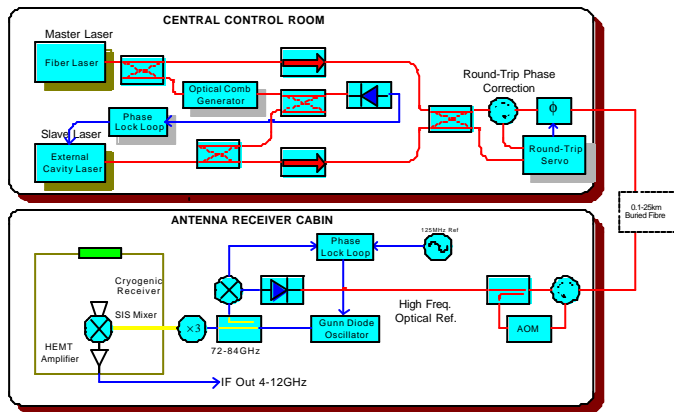

Fig.5 Photonic Local Oscillator block diagram

Since the propagation time along the fibre affects the phase of the LO signal, to reduce the phase variations, the changes in length of the fibre must be kept as small as possible.

In the LO system the fibre length variations are limited by both passive means and active control.

The active control is based on an interferometric subsystem which measures the round trip length and acts on fibre stretching actuators to compensate for the length variations.

The length of the link combined with the light speed sets the bandwidth of the Line Length Corrector, that is constrained to about 1kHz, therefore only disturbances (including acoustic ones) well below such frequency and of limited amplitude can effectively be compensated, the others must be kept low by passive means. Passive means include thermal-stable installation of the fibre, thermal insulation, mechanical insulation.

However in order to keep the cost of the system affordable no usage of special fibres (like low temperature coefficient) was considered.

The complete LO system has been tested in the lab (with the proper length of fibre) and is currently undergoing field tests at the Alma Test Facility (at the VLA Observatory, in New Mexico).

CORRELATOR

The Correlator is the core of the whole ALMA instrument. It is a huge number-crunching machine that gets the real time data from the receivers in the Antennae to perform signal power detection and a first data averaging and processing.

The astronomical data acquired by the Antennae are conveyed to it, in the Technical Building at the operating site. Due to the amount of data to be processed (120*64 Gb/s), the transfer to the base camp (about 40km away) where the operating conditions are less severe was not deemed convenient. Therefore the Correlator has been designed to cope with the conditions at 5000m, which means mainly low power dissipation due to the low air density. The power consumption on the other hand needs to be kept as low as possible also because supplying power at that site is rather expensive.

The whole Correlator is hosted in 32 cabinets comprising station electronics and filtering cards together with baseline correlation cards; the power consumption is in the range of 170kW.

The Correlator has a highly modular and parallel architecture. One essential building block is a custom chip that contains 4096 'lags', each lag consisting of a 2-bitx2-bit multiplier whose output is integrated in an accumulator. There are 64 Correlator chips in each Correlator board processing the data stream at 125MHz clock rate, and there are 512 Correlator boards in the whole Correlator allowing processing all polarization parameters of the incoming waves. The total number of Correlator chips is 32768. The large amount made it convenient the production of an ASIC with respect to a programmed implementation using FPGA's. In addition the low power dissipation could be better addressed with the custom design.

The complete design was performed at NRAO, Charlottesville, and production of the chip was contracted to a specialized company and the result is the "ALMA" chip, produced in the well established CMOS 0.25 micron technology. With the nominal Clock of 125 MHz and the voltage supply of 1.8V, the power dissipation is 1.6 W.

The device is cased in a standard 240-pin PQFP package, this solution has been preferred to the more modern and compact BGA, not requiring highly specialized equipment for mounting/removing to be installed on site for maintenance.

The Tunable Filter Bank

Prior to be digested by the Correlator, the incoming data need to be digitally filtered. This function is performed by the Tunable Filter Bank (TFB). The TFB demultiplexes the 2GHz bandwidth incoming signal into 32 sub bands whose central frequency and width can be independently adjusted according to the scientific needs, providing an unprecedented flexibility to the ALMA instrument.

The TFB is being jointly developed by Université de Bordeaux (F), Osservatorio Astrofisico di Arcetri (I) and ASTRON (The Netherlands).

The basic component of the TFB is a Real/Imaginary double stage FIR filter. The first stage has 128 fixed taps while the second stage has 64 configurable taps and can be tuned to shape the frequency response. This architecture optimizes the usage of the logic/arithmetic resources available in large Field Programmable Array (FPGA) devices.

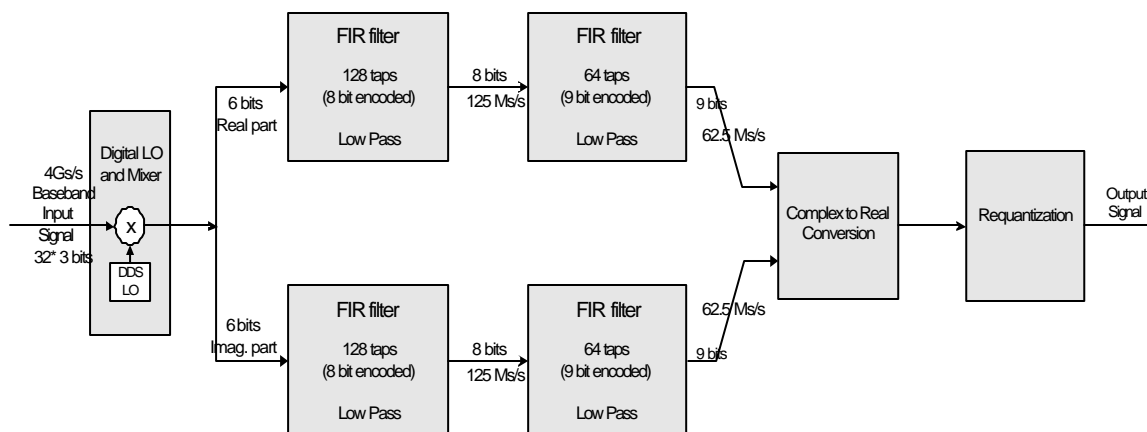

Fig. 6 TFB Filter block diagram

The prototype implementation on which tests and firmware developments are being performed uses large commercial FPGAs assembled on standard size multi-layer printed circuit boards. A study has shown that a compromise between complexity and cost results in an optimum of 2 digital filters per FPGA and 16 FPGAs per board. The Correlator needs 512 such boards, for a total of 8192 FPGAs.

The FPGA solution, however, is a priori not well suited for the series production because of both the relatively large power dissipation and the cost of the devices. On the other hand the complexity and the relatively limited amount of devices needed do not justify a fully custom design. As a consequence a semi-custom implementation making use of a service provided by the FPGA manufacturer to translate on Silicon the FPGA design, saving both Silicon surface and power dissipation is under consideration. An alternative, that would not have the limitation of a 'frozen' programmable design, based on the usage of a more advanced generation of FPGA, is also being investigated.

SUMMARY AND CONCLUSION

One of the most challenging aspects of ALMA is the combination of extremely demanding technical, operational and environmental requirements.

The only way to cope with these requirements is making use of the most advanced technologies.

However this approach involves high risks and high costs, which are particularly emphasized by the custom developments requiring substantial investments and producing components whose long-term behaviour may be uncertain. On the other hand well established technologies, when suitable, are affected by the risk of obsolescence during the 30 years lifetime of the project.

These risks can only be mitigated by properly addressing the custom developments and by adopting an appropriate spare policy to guarantee the availability of the parts for the whole life span of ALMA.

Finding a satisfactory compromise between the application of the most advanced and of the most consolidated technologies is central to the success of this project

As per today almost all ALMA subsystems have been successfully tested. Experimental activity in the field is ongoing at the ATF in Socorro NM (~2000m asl), where two prototype antennae are being outfitted with prototype equipment. But only the final operation at the site, facing the actual environmental conditions will confirm whether a right balance between innovation and reliability has been satisfactorily reached.

REFERENCES

- [1] Draft ALMA 3-bit, 4Gsps Analog-to-Digital Converter Data Sheet, July 13, 2005
- [2] High-Frequency Local Oscillator Transmission for the Atacama Millimeter Array (ALMA) IEEE LEOS Optical Frequency and Time Measurement and Generation Conference, July 2005 (ALMA archive)
- [3] Enhancing the Baseline ALMA Correlator Performances with the Second Generation Correlator Digital Filter System - ALMA memo 476