

TRANSPORT AND INSTALLATION OF CRYO-MAGNETS IN CERN'S LARGE HADRON COLLIDER TUNNEL

K. Artoos, O. Capatina, A. Coin, M. Gielen, C. Hauviller, K. Kershaw, CERN, Geneva, Switzerland

Abstract

The arcs of the Large Hadron Collider (LHC) will contain around 1700 main superconducting dipoles and quadrupoles. The long and heavy magnets are supported on fragile composite support posts inside a cryostat to reduce the heat in-leak to the magnets' super fluid helium bath. The presence of fragile components and the need to avoid geometry changes make the cryo-magnets very difficult to handle and transport. The transport and installation of the LHC cryo-magnets in the LEP tunnels originally designed for smaller, lighter LEP magnets has required development of completely new handling solutions. The paper explains the constraints imposed by the cryo-magnet characteristics, the existing tunnel infrastructure and schedule considerations. The development and realisation of transport and handling solutions are described, starting from conceptual design, through manufacture and testing to the installation of the first cryo-magnet. Integration studies to verify and reserve space needed for manoeuvre and the preparation of the infrastructure for transport and installation operations are also presented. The paper includes conclusions and some of the lessons learned.

INTRODUCTION

The installation of the superconducting LHC machine in a tunnel designed and used for the resistive LEP accelerator imposes significant constraints for the transport and handling equipment. Little space is available for the transport and handling of the larger, heavier and more fragile cryo-magnets in a tunnel that also houses the cryogenic supply line, significant instrumentation cabling and pipe work (Fig. 1). The CERN study of transport and handling solutions for the LHC machine resulted in an integrated, conceptual design. This conceptual design formed the basis for two technical specifications [1], [2] covering transport and handling that were used for competitive tendering throughout the CERN member states. The specifications enumerated the constraints and the functional requirements leaving the possibility for the bidders to propose technical solutions. The specifications imposed significant test programmes at the contractor's premises and in the LHC tunnel. Test procedures were written to ensure compliance with the technical specifications. The conceptual designs, specifications and final designs were also used at CERN to integrate the magnet transport and handling with the other components and infrastructure in the LHC tunnel.

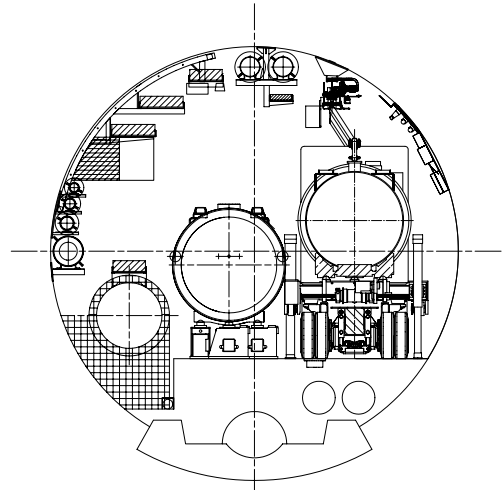

Figure 1: Cross section of the LHC tunnel with a transported magnet next to an installed magnet

CONSTRAINTS

Cryo magnets

The transport vehicles and handling equipment have to transport and install cryo-magnets: main dipoles, Short Straight Sections (SSS) and Long Straight Section (LSS) magnets of different weights, lengths and with different support points as summarised in table 1.

Table 1: Number and type of cryo-magnets to be installed in the arcs and the straight sections

	Number	Mass (t)	Length (m)
Main dipole	1232	34	16.3
SSS Arc	360	8	7.5
SSS DS*	64	11-14	8.7-10.1
LSS	64	4.7-22.7	8.5-13.2

The 1100 mm wide cryo-magnets all contain heavy cold masses that are mounted on fragile composite supports. Such fragile components and the required magnet geometry stability resulted in strict limits for accelerations and tilt in all three directions [3].

Tunnel infrastructure

The LHC cryo-magnets will be lowered via a new access shaft PMI2 and transported through a 1.8 km long transfer tunnel TI2 to the 27 km long LHC ring tunnel. The LHC tunnel is inclined at 1.4 % with local slope changes up to 1 %. The steepest slope on the cryo-magnet transport route is 2.6 % in the TI2 tunnel.

* DS : Dispersion suppressor

The width available for transport and unloading of magnets can be as narrow as 1250 mm (Fig. 1). The space constraints impose a maximum vehicle width of 1000 mm and a maximum trailer height of 500 mm.

A considerable amount of integration work was needed to reserve volumes for the transport and handling of the cryo-magnets. The integration study also showed the necessity to build new or modified galleries to allow the vehicles to go around the LHC experiments. The passage through such bypass galleries is very tight for the cryo-dipoles.

The LEP monorail was retained and reinstalled over 4 km to provide electrical power for the tunnel vehicle. The I section rail will also be used for handling of tooling during magnet installation.

The concrete floor surface was prepared to ensure that there are no steps or cracks over the specified 8 mm. Metallic items in the floor were reinforced to accept the loads imposed by the vehicles and the handling equipment.

Installation interfaces

The cryo-magnets will be installed on support jacks fitted with spherical bearings. The minimum height under an installed magnet is 300 mm. The spherical bearings and overlapping interconnects of the cryo-magnets impose a horizontal lateral installation trajectory followed by vertical lowering of 30 mm. The tolerance for the magnet to follow this trajectory in all directions is 1 mm.

Schedule

The maximum defined speed of 3 km/h with load and 4 km/h without load and maximum required time needed for different transport and handling steps were based on the general LHC installation schedule along with space and acceleration constraints.

CONCEPTUAL DESIGN

The requirements mentioned above resulted in a conceptual design for the transport and handling of the cryo-magnets in the LHC tunnel.

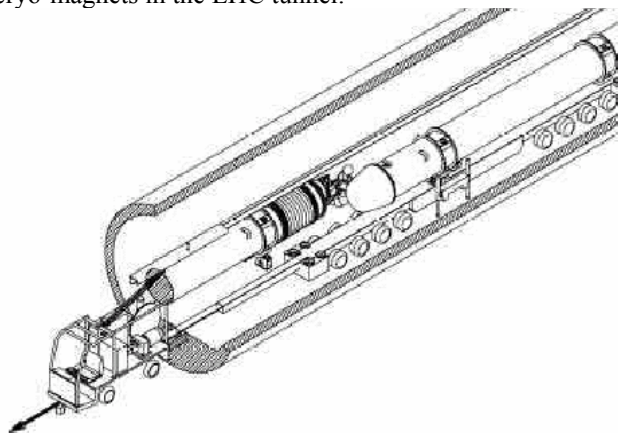

Figure 2: The tunnel vehicle is withdrawn from under the magnet on the unloading equipment

The magnets are transported on a trailer or Magnet Transport Unit MTU adapted to the type of magnet. Three different trailer types are used to transport the different magnets in Table 1. An Operator Transport Unit OTU is connected to each side of the MTU to make up the tunnel vehicle. The vehicle transports the magnet to the place of installation powered by the overhead power rail and automatically steered by a guidance system. The magnet is then raised by hydraulic cylinders in the MTU and an Unloading Equipment (UE) is positioned under the magnet to support it. The trailer can then be withdrawn from under the magnet (Fig. 2).

Two transfer tables, making up a Transfer Equipment Set (TES) can then be positioned under the magnet. The TES can handle the cryo-magnets with 6 degrees of freedom and high precision (0.1 mm). The TES takes over the cryo-magnet from the unloading equipment and aligns it with respect to the magnet support jacks. The magnet is then transferred horizontally at a height allowing the passage of the magnet interconnects and finally lowered onto the support jacks (Fig. 3).



Figure 3: Transfer with TES of a short straight section to the magnet support jacks. In the background a cryo-dipole already in its tunnel position

CONSTRUCTION

The development and construction of the transport vehicles and unloading equipment was contracted to a consortium formed by Babcock Noell Nuclear and MAFI Transport-Systeme of Germany. The transfer tables were contracted to ZTS VVU KOSICE of Slovakia. The final design of tunnel vehicles and transfer tables follow in general the conceptual design. Below are given the major technical solutions developed to comply with the tight constraints mentioned before.

Tunnel vehicle

Two-compound solid rubber tyres were used instead of the more compact polyurethane tyres. This resulted in more, wider wheels but gave excellent vibration behaviour when driving over the tunnel floor.

The high loads and the limited permissible dimensions of the vehicle imposed an automated, fully hydraulic solution for the driving, steering, lifting and the use of a hydraulic suspension.

An optical system based on a line painted on the floor was implemented to guide the vehicle past installed components with only about 10 cm clearance and through the complicated passages going around the caverns for the experiments. The measured repeatability of the guidance line following is better than 2 mm in the tunnel arcs.

The hydraulic brake system is designed to respect the longitudinal acceleration limits, even during an emergency stop or power cut.

Transfer tables

A fully modular and electrical solution was developed with units based on stepper motors and harmonic drives for lifting, transferring, driving and steering, attached to a central frame.

The installation has been fully automated by measuring the position of all components with a theodolite. The coordinates are entered in the control system and a mathematical model calculates the trajectory to follow respecting the tilt, applied force and acceleration limits.

STATUS

Acceptance testing

A thorough important test programme was extracted from the technical specification by regrouping the required functionalities. This helped the contractors to remain focussed on complying with all the detailed requirements of the specification. The tests were first carried out at the contractor's premises using tunnel and full weight magnet mock-ups. This has been particularly useful for the hardware and software development of the transfer tables. The same test programme was then repeated in the LHC tunnel with the real infrastructure. LHC cryo-magnets were lowered in the PMI2 and transported to the LHC tunnel with the tunnel vehicle. The magnets were then successfully installed on the support jacks in the tunnel using the TES.

Three tunnel vehicles, two for cryo-dipoles and one for SSS are being tested at CERN. One vehicle for cryo-dipoles and LSS elements and one vehicle for SSS are ready for factory testing. Three transfer table sets were completely tested and accepted at CERN; one more TES is ready for factory testing.

The acceptance testing at CERN helped to prepare the transport infrastructure for the final installation. Tools were developed to commission the 27 km long transport infrastructure sector by sector, in particular the overhead power rail, before the first test runs with the vehicles. Figure 4 shows the unloaded cryo-dipole tunnel vehicle following the guidance line in the bypass galleries around one of the LHC experiments.



Figure 4: A cryo-dipole transport vehicle follows the guidance line in a bypass tunnel.

CONCLUSIONS

Several constraints, especially the very restricted space available, have demanded an innovative concept for transporting and installing the LHC cryo-magnets in the LHC tunnel. Very detailed functional specifications led to ease of verification of compliance of bids, allowed contracts to start up quickly in the design phase and have provided a clear basis for any discussions during the contract. The use of elaborate full scale mock-ups and a detailed test list based on the specification during the factory testing helped the contractors to fulfil the specified requirements. At CERN, the conceptual design, technical specifications and final design were used to define and verify magnet interfaces and ensure compatibility with civil engineering and technical services in the tunnel. The test list was used to repeat the equipment tests in the LHC tunnel, thereby commissioning the transport infrastructure at the same time. The first LHC cryo-magnets were transported in the LHC tunnel and temporarily installed on magnet support jacks to validate the concept and the technical solutions before the start of the final installation.

REFERENCES

- [1] Technical specification for the supply of cryo-magnet transport vehicles and unloading equipment for the LHC tunnel; <https://edms.cern.ch/file/111918/1/it2803description.pdf>
- [2] Technical specification for the supply of precision transfer equipment sets for LHC Cryo-magnets Installation; <https://edms.cern.ch/file/335628/1/it2952specification.pdf>
- [3] K.Artoos et al.; Mechanical dynamic load of the LHC arc cryo-magnets during the LHC installation. EPAC 2004, Lucerne, Switzerland