

TOWARDS A UNIFIED GENERAL PURPOSE CAD SYSTEM AT CERN

T. Hakulinen, C. Andrews, B. Feral, P-O. Friman, M. Mottier, T. Pettersson, C. Sørensen, E. Van Uytvinck, CERN, Geneva, Switzerland

Abstract

Several different CAD systems are in use at CERN today. Most of the 3D design work for the LHC is being done using Euclid from MDTVision. For 2D design work AutoCAD is widely used. Also, various special design tools exist for tasks such as electrical design and schematics. Even though the LHC design will be finished with Euclid, it has been clear since several years that a new 3D CAD system will be needed in the future. For this reason CERN carried out a comparison between the currently available 3D CAD software on the market using a set of selection criteria important for CERN. The selected system was CATIA from Dassault together with local data base system SmarTeam. The aim is to use CATIA as a multi-disciplinary general purpose CAD tool, which could eventually replace almost all of the other CAD systems at CERN. For this purpose, CATIA and SmarTeam are being integrated with the existing CAD utilities and database systems developed in-house. Pilot users are using the system for real designs while the digital mock-up features of CATIA are used in integration studies of LHC experiments. The feature list of CATIA and SmarTeam is impressive and experience with the software has so far been almost exclusively positive. This is promising for software with which CERN will likely have to live for the next 20 years or more.

INTRODUCTION

Computer aided engineering systems are a key factor in the design and construction of today's particle accelerators and experiments. At CERN, many different CAD systems have been in use, of which AutoCAD and Euclid 3D are presently officially supported. Official design drawings are stored in the CERN EDMS/CDD system (Engineering Data Management / CERN Drawing Directory) [1].

Development of Euclid has ended and its lifetime is nearing the end. Therefore, in 2003 Catia V5 by Dassault Systemes [2] was selected to succeed Euclid as the future 3D CAD software at CERN. In the coming years, the big challenge for the CERN CAD community will be the introduction of this completely new 3D CAD system. For the CAD support team this implies software development on one hand and definition of new design methodologies on the other.

Eventually Catia together with its local database system SmarTeam should become the only centrally supported CAD tool at CERN replacing both Euclid and AutoCAD. However Euclid will be used to finish all the design work on the LHC project and AutoCAD will most likely remain in use by external users.

CERN CAD ENVIRONMENT

The official CERN CAD systems are supported by a central CAD support team from CERN Technical Department. This includes the daily activities related to designers, configuration management of the commercial CAD systems, and development of CERN-specific applications and utilities to be used in design work. In the following list are presented some of the various CAD-applications developed at CERN over the years:

- *Digital Mock-Up* (DMU) application, which is being used extensively for the LHC integration studies.
- *WebConsult* utility for CAD data exchange, which allows external firms and institutes to retrieve 3D-models in various formats.
- *Docmrp* and *Scandoc* utilities, which were developed to document and search objects inside Euclid databases.
- *3D-standards* allow management of lightweight versions of official Euclid 3D equipment models with respect to the different coordinate systems in use at CERN, which makes it possible to display most of the LHC installations interactively with Euclid or Catia.
- *CartWeb* is a Web-based interface to register drawings in EDMS/CDD and to manage drawing title block data, parts lists, and modification lists from all supported CAD systems.
- Automatic archival pipelines exist for Euclid, AutoCAD, and Catia, which stamp and archive official drawings according to the approval status of the drawings in CDD.
- *The CERN HP-GL viewer* provides a way to display official drawings on most computer platforms independently of the native CAD system.

THE CATIA V5 PROJECT

Catia V5 is an extremely powerful and versatile CAD system with many features and modules for different design tasks. It is a major rewrite of the previous Catia V4 and as such it is relatively new software. On one hand this means that the software supports modern design paradigms and that it is being actively developed. On the other hand, effort is needed to evaluate the readiness of the different modules for production use. New Catia releases come out at the pace of roughly twice a year, which means that the situation is changing rapidly.

The many features of Catia make it possible to federate many of the engineering disciplines needed in accelerator

and detector design. The aim of the CERN Catia project is to adapt the Catia software and its data manager SmarTeam to the existing framework of software and design methodologies at CERN.

A Catia pilot project is underway to gain first hand experience with the software in order to develop a consistent methodology for Catia use. The pilot project involves the design of the LEIR machine based partially on the old LEAR installation. Catia is used for the mechanical design of new components as well as modelling of the existing ones based on old paper drawings for the purpose of integration. Feedback and experience gained from the pilot project will be indispensable when preparing the full deployment of Catia at CERN.

USE OF CATIA AT CERN

Since Catia has the ability to support many applications for different disciplines on one platform, this can lead to better sharing of data, fewer data conversions, more coherent methodology, and improved all around working efficiency. With this in mind, the different Catia modules are being evaluated to see if they are mature, usable, and conform to CERN requirements. Afterwards, once a methodology has been written and the modules properly configured, they can be deployed in production. This work will require the expertise and commitment of specialists in each discipline in question.

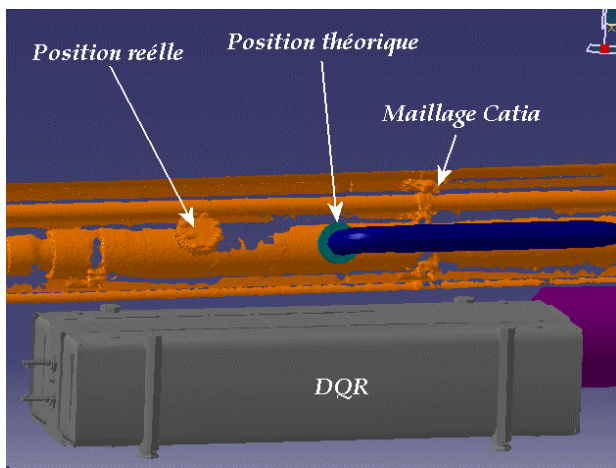

Figure 1: A Euclid model superimposed over a model derived from point-cloud in Catia. A position disparity between the model and installed equipment is clearly visible.

The first disciplines to benefit from the introduction of Catia are the conceptual and detailed part and assembly design and drawing creation within the pilot project. The ATLAS experiment does integration studies with the DMU module, and the LHC machine also uses the DMU for installation studies. During the actual installation of LHC equipment, Catia is used for meshing point-clouds from real measurement data obtained in the LHC tunnel

with a laser scanner. The meshed measurement data together with the corresponding theoretical Euclid models are then checked in a Catia session (Fig. 1).

It is also possible to use Catia to carry out simple finite element analysis. This allows the designer to perform rough design checks and iterations at an early stage without involving the external Ansys/DesignSpace system. For a more detailed and extensive analysis later on, Catia can also be used as a 3D modeller for Ansys. The full FEA capabilities of Catia are being evaluated.

Additional modules exist among others for sheet metal design, welding, metrology, cabling, tubing, manufacturing, and schematics design. These modules are yet to be studied and configured for use at CERN.

CAD DATA MANAGEMENT

Designs created with a complex CAD system such as Catia with many different modules normally consist of many different interlinked files and file types, which need to be stored, tracked, and kept under version control during the lifetime of the design. Designs may also contain application specific and context sensitive metadata, which normally might not be managed by the CAD system itself. Furthermore, in a multi-designer environment such as CERN, where many people work on the same project, it is imperative that CAD data can be shared in a consistent, coherent, and secure manner.

Managing all Catia design data is the job of SmarTeam, which is the local data manager for Catia [2,3]. SmarTeam is tightly integrated with Catia, which means that it knows about all Catia data types and is able to automatically keep track of all the links between CAD files so that the use of SmarTeam is as transparent to designers as possible. The metadata are stored in an Oracle database and the CAD files themselves are kept on a separate centrally managed vault server. An object oriented programming interface exists to allow applications written in Visual Basic, C++, or Java to access and manipulate the SmarTeam database.

The role of SmarTeam at CERN is strictly to manage the internal CAD design data during the actual design phase and to store the native files of all finished designs for the future. EDMS/CDD will remain the repository of all official drawing data and act as the public interface towards collaborating institutes and supplier firms. The official approval process of drawings produced from Catia designs will be carried out in CDD with the approval status reflected back to SmarTeam. For the official designs, the SmarTeam high level project tree hierarchy will reflect the CDD equipment code structure to facilitate mapping of metadata between the two systems. Within SmarTeam equipment folders designers are then free to organise their work as they see fit.

SmarTeam is currently being tested and used internally within the development team. The next step is to introduce it to the Catia pilot project to allow the actual LEIR design data to be stored there.

The SmarTeam interface is shown in Fig. 2 with an assembly selected from the project tree and a 3D preview of the assembly visible. In Fig 3. the assembly has been opened in Catia.

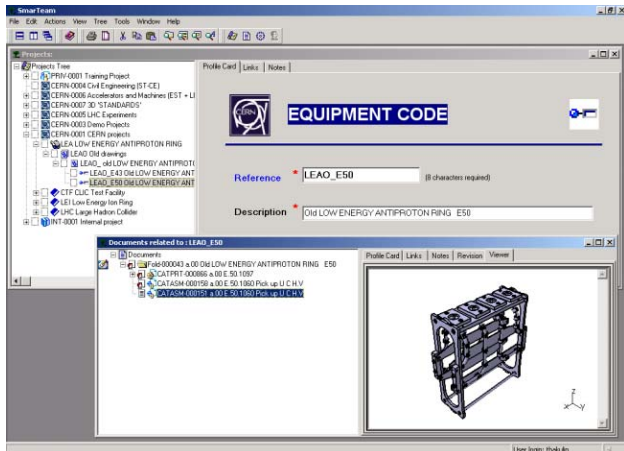

Figure 2: A SmarTeam session. A high level project structure and the document structure within a subproject are shown with a preview of the assembly.

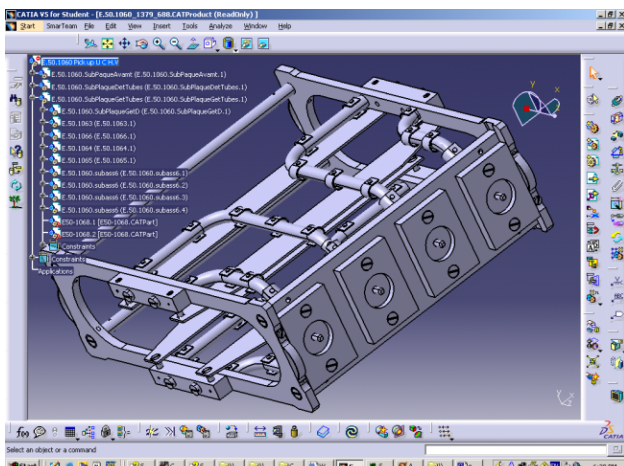

Figure 3: An assembly in Catia session. A partially expanded subassembly tree is visible on the left.

INTEGRATION OF CATIA INTO CERN INFRASTRUCTURE

To make Catia work well in the CERN environment, installation and configuration procedures have been developed to ensure a uniform environment on all machines. Installation of Catia uses the normal Windows application installation mechanisms and Catia configuration options are being centrally managed. Work is also underway to make Catia work with the key CERN specific applications:

- The title block editor CartWeb for Catia and the automatic archival pipeline for Catia drawings are in production with the pilot project.
- Integration and migration of Euclid 3D standards to Catia is underway. The Euclid 3D models are

converted to full Catia native format as well as to a more compact simplified representation format useful for building digital mock-ups in Catia. However, care must be taken, because even within the files successfully converted there may still be errors. Therefore, for migration of any full Euclid models to Catia, manual checking will always be necessary afterwards.

- The interface and data exchange protocol between SmarTeam and EDMS are being developed. It will be possible to initiate the approval process for designs managed by SmarTeam from the SmarTeam interface. Any supporting documents for the approval, including the official drawing file as well as a portable 3D representation will be transferred from SmarTeam to EDMS. As the approval process proceeds, the approval status will be reflected in SmarTeam. When the approval process is active and after a successful approval, all the corresponding design files will be frozen in SmarTeam so that a new version of the design has to be created in order to edit it.

METHODOLOGIES AND TRAINING

Possibly the biggest challenge facing the Catia project is that of development of consistent methodologies for the large number Catia modules and the subsequent effort needed in user support. Given the eclectic nature of Catia, consistent and tested methodologies are an absolute necessity to ensure interoperability between designs. These methodologies can only be properly defined as experience is gained on the various design disciplines over a considerable amount of time.

The last big issue is training for the Catia users. All Catia users should receive training before being allowed to work on official designs. An on-line tutorial comes with the software, which can be used to brush up on one's Catia skills, but it is obviously no substitute for proper user training by a competent teacher. In-house training will have to be developed at least for the CERN specific methodologies and applications.

CONCLUSIONS

Introduction of the new CERN 3D CAD system, Catia and SmarTeam is well underway. As the technical issues are being rapidly worked out, challenges lie ahead in the form of methodology development as well as user training and support. Once all these issues have been addressed and the system is fully operational, CERN can expect Catia and SmarTeam to serve it well for the foreseeable future.

REFERENCES

- [1] <http://edms.cern.ch/>.
- [2] <http://www.3ds.com/>.
- [3] <http://www.smarteam.com/>.