

## LOGISTICS OF LHC CRYODIPOLES: FROM SIMULATION TO STORAGE MANAGEMENT

K. Foraz, B. Nicquevert, D. Tommasini, CERN, Geneva, Switzerland

### Abstract

The main families of LHC superconducting cryomagnets consist of 1232 cryodipoles and 488 quadrupoles. The different contracts, which are constraining the production and installation of these cryomagnets, have been initially rated according to the baseline schedule, based on a "just in time" scheme. However the complexity of the construction and the time needed to fully test the cryomagnets require that each contract is decoupled as much as possible from the others' evolutions and impose temporary storage between different assembly and test activities. In this paper the organisation of cryomagnet flow and the main challenges of logistics are analysed on the basis of the planning of each main step before installation in the LHC. Finally, the solutions implemented for storage, handling and transport are presented and discussed.

### INTRODUCTION

The LHC cryomagnets are delivered at CERN, some of them as almost completed units, but most of them request to be assembled before they are ready to be installed in the tunnel. The different contracts involved in the assembly and preparation process at CERN are in place and the main assembly activities are well advanced. However the delay in the availability of the tunnel for cryomagnets installation imposes the set up and management of storage areas and handling operations far beyond what was expected one year ago.

### CRYODIPOLES WORKFLOW

The assembly work for cryomagnets to be performed at CERN consists of 18 work packages executed in sequence by different contractors and at different locations. The organisation for cryodipoles main components between the cold masses delivery and their final transport down in the tunnel are summarised below.

For the dipoles, the cold mass and the cryostat arrive at an area named point 18 (see figure 1). The magnets are

controlled, assembled and prepared for the cold tests in building SMA18.

After transportation from assembly stands to test bench in building SM18, the cryodipole is cold tested, and then prepared in building SMA18 for the interconnection in the machine. Afterwards, it is transported to another area in building SM12 where it is finally equipped with ancillary equipment (beam screens, etc...), and made ready for installation in the tunnel.

### STORAGE SIMULATION

The contracts for the main components and activities are now in place. Originally, the planning of this whole process was based on a "just in time" scheme, but the delivery, assembly and test rates of these very highly advanced products, as well as the availability of their final position in the tunnel, are different than those foreseen in the different contracts. Therefore, buffer storages between each main activity need to be implemented, and transport between sites to be analysed in term of resources (material and manpower). For this purpose, a simulation tool was created giving the number of cryomagnets to be stored between each activity, as well as all the relevant time information concerning one cryomagnet trip between its cold mass arrival to its final installation in the tunnel.

#### Simulation tool

The inputs are:

- The rates for the different activities given by project engineers, i.e. the rate for cold mass delivery, assembly, test, preparation in SM12 and transport;
- The cryomagnet list, coming from the LHC reference database [2];
- The installation schedule [3]: the cryomagnet transport in each sector is constrained by the cryogenic line installation (QRL), and by the maximum rate for underground transport. The updated schedule (April 2004) assumes that all the cryomagnets would be transported from June 2004 to October 2006, with a given rate in each sector.

The tool simulates how much storage is needed between each activity, by calculating for each week the difference between the number of cryomagnets treated by activity  $n-1$  and the number treated by the activity  $n$ . The results are presented graphically in Figure 2.

Then, starting from the installation scheme defined by the planning team, the simulation tool calculates when one cryomagnet should be prepared, tested and assembled according to the different rates given by project engineers.

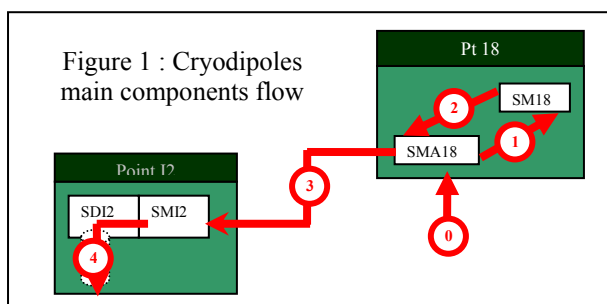

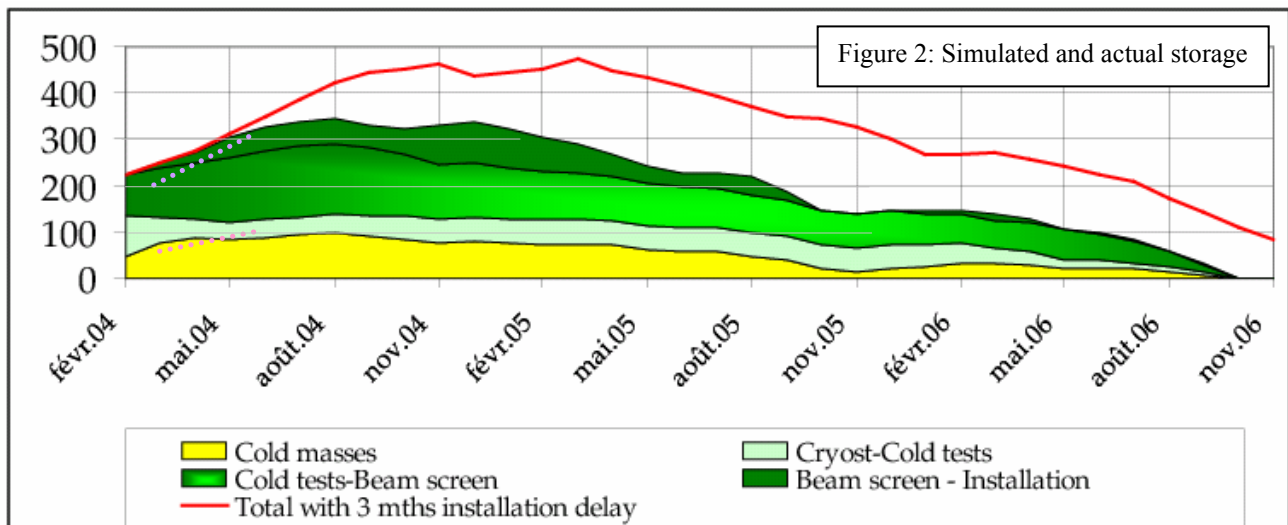

Figure 2: Simulated and actual storage

### First results

According to the simulation performed in April 2004 (see Figure 2), the maximum amount of cryodipoles to be stored would have been approximately 320 cryodipoles and 100 cold masses. This maximum would have been reached in August 2004, whilst the installation in the tunnel would have started but still not exceeding the quantity of cold masses delivered. The curve would start to decrease when the transport rate would raise its “cruising speed” (between 15 and 20 per week, depending on the sector), larger than the rate of any other activity.

A new simulation, run in June, shows the impact (figure 2, top curve) of a 3 months delay on start of installation (delayed to September) : the maximum of stored cryodipoles goes up close to 500, and total duration of storage activity is lengthened by 3 months.

The actual rate (shown in dot lines both for cold masses and for total number of cryodipoles) is about equal, if not slightly higher to that expected. The tendency was nicely anticipated.

## STORAGE STRATEGIES

### The transportation and handling means

The main challenge is to transport the cryodipoles, which are 16.5 m long, 34 tonnes objects standing on three insulating supports in a vacuum vessel. During transportation the transversal acceleration cannot exceed  $5 \text{ m/s}^2$  to keep the stresses on the cold mass supports within acceptable limits [1]. A dedicated trailer, with a 100 ton capacity (up to two cryodipoles), is used for this purpose. The main mobile crane has a 160 ton capacity, and is able to move the load of 40 ton (cryodipole with handling tool) up to 12 m. A new trailer was recently made operational (figure 3, with mobile crane).

### The various zones and related capacities

The initial plan was to store 150 cryomagnets, without individual sorting. The policy was based on a LIFO (*Last In First Out*) logic. It was therefore possible to deal with

only one storage area, the LEP dismantling zone called 1027, which offered the necessary space. The additional constraint to be able to reach any magnet at any time (individual sorting) arose during summer 2003. The capacity of the 1027 cryomagnets is then 100, in order to cope with the necessary additional dead space for the evolution of the mobile crane. The proposal was then to have a unique long stack of magnets.

Given the results of an initial simulation, it appeared clearly that the capacity of the zone would not cope with the huge amount of cryomagnets to be stored.

At the beginning of 2004, the decision was finally taken to store the cold masses in order to avoid saturation of SM18 external storage areas, leading to quick saturation of the 1027 zone (as can be seen in the background of figure 3).

A second zone was then created, along the road, still at Prévessin. In March, 23 cryodipoles were put on large heavy concrete blocks, and more than 35 cold masses were stored on only 2 dedicated wood cradles, with a 9 m span, in order to avoid any induced torque.

At that point, the overall storage were estimated at about 200 cryomagnets, all in all. Saturation was anticipated to happen in May, and it was decided to proceed with the preparation of a new zone near point 18, called point 19.

### Situation at point 18

All magnets to be stored were coming, in this initial phase, from point 18. The logistics in this area is heavily constrained. Cold test benches are the bottleneck of the project, and demand to be fed in real time. The unique logistics mean for this are the Rocla robots. In addition, there is only one external crane, whose hook coverage zone is limited.

Close to point 18, small storage zones were created, with purpose to offer a buffer zone to cope the cold masses slightly exceeding the just-in-time capacity of SM18.

The time between the authorization for storage of a given magnet, and its actual storage, need to be kept less

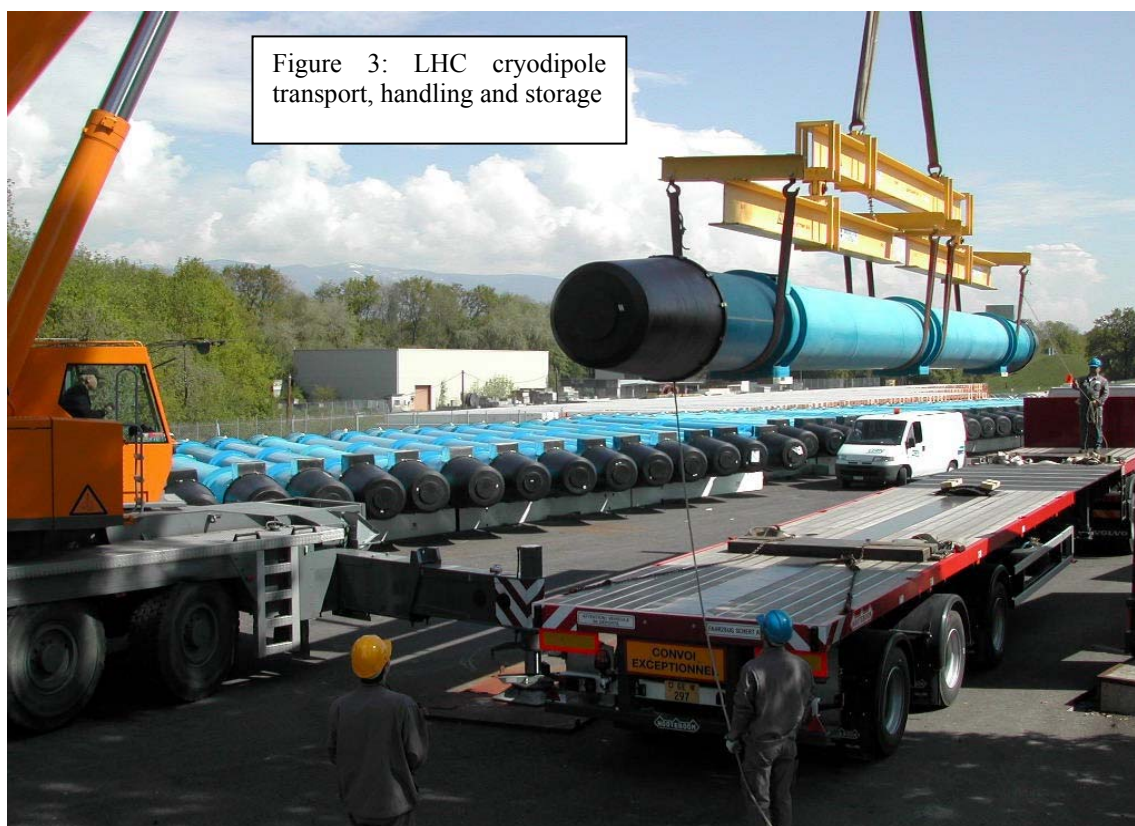

Figure 3: LHC cryodipole transport, handling and storage

than three days, if the number of buffered magnets is not to exceed the capacity below the crane. Transport activities are hence permanently on the critical path, and can be seriously perturbed in the case of unavailability for more than a few days of one or the other means. Unfortunately, it may occur.

Use of mobile cranes is always risky, not only in case of bad weather. One of the most worrying issues is the floor of the storage surfaces, with a risk to collapse below the crane, and to crash a magnet. Floor limits were hence analysed and are better known, and new procedures impose the compulsory use of large steel plate below the feet of the cranes.

### *Situation and prospective*

Early May, the first magnets after insertion of beam screens at SMI2 were announced to be ready for storage. But the remaining storage capacity was dramatically less than 20 units (2-3 weeks capacity). 80 cold masses and 140 cryodipoles were stored, with an occupancy rate of above 95%. After start of use of point 19 area, the capacity more than doubled. After final extension, the total capacity will be above 450 cryodipoles, and no new storage crisis should happen by October 2004. Mid June, the figure of 100 cold masses was reached, and more than one full sector was stored (154 cryodipoles).

### **CONCLUSION**

Due to the evolution of the different contracts, it is important to simulate and follow the cryomagnets surface

flow, in order to have a clear overview of the storage space and location.

We would like to highlight the difficulty involved in dealing with many transports in various areas within a limited time-frame. The need for individual sorting leads to access constraints, and requires frequent moving from one area to another. The danger of these manipulations has to be underlined: cryodipoles are heavy, fragile and dangerous objects.

Transport of cryodipoles is the life-blood of the project. This daily activity seems to be rather straightforward; however, its criticality was shown, and it will demand a very good coordination throughout the whole installation.

### *Acknowledgments*

The people involved in this simulation and storage undertaking are too numerous to be mentioned. The authors would thus like to sincerely thank all members of the Installation Coordination group, those involved in transport and handling operations, and those who provided the information input to perform the simulation.

### **REFERENCES**

- [1] K. Artoos *et al.*, "Transport and installation of cryomagnets in CERN's LHC tunnel", EPAC '04, Luzern, July 2004
- [2] P. Le Roux *et al.*, "LHC Reference Database", EPAC '04, Luzern, July 2004
- [3] K. Foraz and S. Weisz, "Installation Schedule of Machine Elements in the Continuous Cryostat of Sector 7-8", CERN/LHC-PM-MS-0013