

## SPEAR3 LARGE DC MAGNET POWER SUPPLIES\*

P. Bellomo, A. de Lira\*\* (SLAC)  
Menlo Park, CA 94025-7015, USA

### Abstract

The Stanford Synchrotron Radiation Laboratory (SSRL) has successfully commissioned SPEAR3, its newly upgraded 3-GeV synchrotron light source. First stored beam occurred December 15, 2003 and 100mA operation was reached on January 20, 2004.

This paper describes the specification, design, and performance of the SPEAR3 DC magnet large power supplies (LGPS) that consist of tightly-regulated (better than  $\pm 10$  ppm) current sources ranging from 100A to 225A and output powers ranging from 70kW to 135kW. A total of 6 LGPS are in successful operation and are used to power strings of quadrupoles and sextupoles.

The LGPS are isolated by a delta/delta-wye 60Hz step-down transformer that provides power to 2 series-connected chopper stages operating phase-shifted at a switching frequency of 18-kHz to provide for fast output response and high efficiency.

Also described are outside procurement aspects, installation, in-house testing, and operation of the power supplies.

### INTRODUCTION

The Stanford Synchrotron Radiation Laboratory (SSRL) has successfully commissioned SPEAR3, its newly upgraded 3-GeV synchrotron light source [1].

The Power Conversion Department (PCD) [2] at the Stanford Linear Accelerator Center (SLAC) was responsible for defining, jointly with SSRL, the topology of the SPEAR3 DC magnet large power supplies (LGPS), their operating requirements, as well as working on the procurement process, pre-installation testing, installation, and commissioning.

On-site installation of the LGPS began mid-2003. Testing started in November and was finished by mid-December [3]. Table 1 summarizes the basic characteristics of the LGPS.

This paper describes the outside procurement aspects, in-house testing, installation, and commissioning of the SPEAR3 LGPS.

Table 1: SPEAR3 DC Large Power Supply Ratings.

Magnet Strings	Volts	Amps	P(kW)	PS Qty
Quadrupoles	700	100	70	4
Sextupoles	600	225	135	2

\* Work supported by the U.S. Department of Energy under contract DE-AC03-76SF00515.

\*\* delira@slac.stanford.edu

### GENERAL ASPECTS

All LGPS use a Bitbus [4] controller for interface, control, and accurate output current regulation. See figure 1 for details. Internally, the LGPS operate as 500-ppm voltage sources. Their voltage control loops have a 3-dB small-signal bandwidth greater than 1 kHz, which is enough to compensate for input line changes and transients. The external, highly-stable, precise, and accurate Bitbus-based current control loop applies a programming reference to the LGPS output voltage regulator for desired output current.

During field testing, the parameters of the proportional-integral (PI) compensation circuit internal to the Bitbus controller were determined by taking into account: the desired current loop control bandwidth, the LGPS voltage gain, and by measurements of load inductance and resistance. The overall system (LGPS and load) then exhibits a 3-dB current control loop bandwidth of 10Hz, which is sufficient to correct the slow magnet resistance variations due to temperature changes, and the drifts in the LGPS voltage control loop.

All LGPS are equipped with latched interlocks to detect abnormal conditions, such as input voltage out-of-range, cabinet and heatsinks over-temperature, door(s) open, fuse(s) blown, output DC overvoltage or overcurrent, IGBT overcurrent or load ground fault. On the LGPS front doors LED indicators are provided for each one of these signals.

A Programmable Logic Controller (PLC) sums the interlocks external to the LGPS. The Bitbus controller receives that summary of external interlock information and turns the LGPS off under abnormal conditions such as magnet over-temperature or cooling-water flow loss.

For monitoring purposes and to facilitate troubleshooting, important operational signals - internal to the power supply cabinet - are provided on the LGPS front panel through isolation amplifiers.

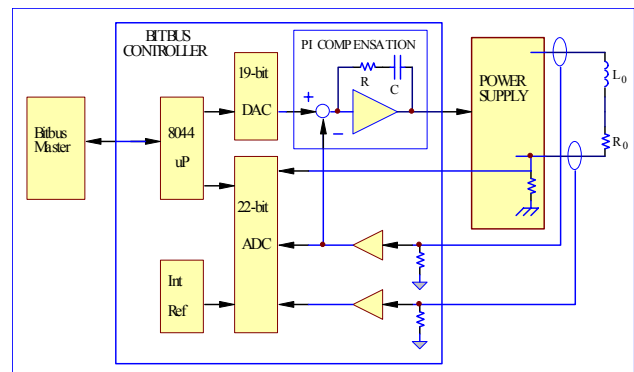

Figure 1: Basic Topology for Bitbus-Controlled LGPS.

## POWER SUPPLY TOPOLOGY

Six (6) large power supplies (70kW to 135kW) are in operation at SPEAR3. These are enclosed free-standing units that power magnet strings of quadrupoles and sextupoles.

As seen in figure 2, the basic power scheme employs two 18-kHz 180° phase-shifted buck converters, each one powered by the secondary of a step-down  $\Delta / \Delta$ -Y line transformer. This allows for a 12-pulse rectification that virtually eliminates the 5th and 7th line harmonics, and reduces line current distortion (THD) to less than 5%. A resistive step-start system limits the inrush current during power ON.

Two cascaded 5-kHz LC filters, each yielding an effective -40dB/decade of ripple attenuation, follow the two alternating-switched buck converters.

Voltage output regulation is accomplished by means of pulse-width modulation on the buck converters.

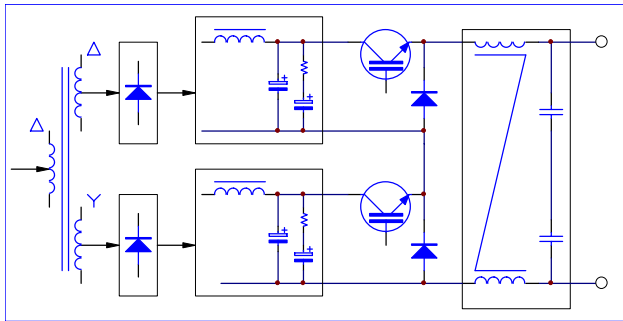

Figure 2: LGPS Basic Power Topology.

## PROCUREMENT ASPECTS

SSRL/PCD jointly specified [5] the minimum requirements, the topology, and required performance, as well as the details on the interface with the Bitbus controller. A twenty year continuous-operating lifetime was specified. A SLAC-designated committee specified seismic criteria in the structural design to minimize damage and hazards during earthquakes. A free-standing design was the best option for the LGPS.

Four 70kW LGPS were to be air-cooled, while the two 135kW units are water-cooled. Main power for all LGPS is 480VAC, 3-phase. In order to facilitate troubleshooting, an separate 120VAC/20A control power is provided to each LGPS for internal electronics, fans, and controls. Per NEC article 460-0, installation of redundant bleeding resistors was required across any capacitor or capacitor bank operating with voltages higher than 50VDC or stored energy of more than 50J.

During the procurement cycle, several manufacturers participated in the bidding process. Technical and cost considerations dictated manufacturer selection. As of July 2002, LGPS costs were US\$ 0.393/W for the 70kW units and US\$ 0.259/W for the 135kW units. Cabinet dimensions are the same for all LGPS: 1.0m (39") width, 1.1m (44") depth, and 2.1m (84") height.

Before fabrication authorization, the selected manufacturer conducted a design review with SSRL/PCD representatives. All outstanding issues were resolved as a prerequisite for fabrication release. SLAC provided the manufacturer with the precision output zero-flux current transducers and Bitbus controllers to be installed inside the LGPS cabinets. Still during the construction phase, and when the first article was ready to be tested, an SSRL engineer witnessed and participated in the testing.

The manufacturer made long-term (24-hour) current stability and component temperature rise tests at the factory on each LGPS. Without taking into account the infant mortality and initial design related failures, the calculated reliability (MTBF) is in the order of 200,000 hours.

A 3-dB small signal bandwidth of 1 kHz for the voltage control loop was specified. Voltage loop frequency response was adjusted and tested at the factory. Delivery of the units occurred in August 2002.

## LGPS TESTS AND INSTALLATION

Upon arrival to SLAC, the LGPS underwent extensive inspection for loose mechanical and electrical connections. PCD added common-mode noise-reduction input and output line filters [6] to bring the LGPS into conformance with EMC requirements.

Prior to final installation in the SPEAR3 power supply room, PCD tested every LGPS with a resistive load as an integral part of the destination system with appropriate interface controls. Diurnal current stability measurements were repeated to verify that, indeed, the LGPS presented the specified requirements. Figure 3 illustrates a typical stability plot on one of the 700V/100A LGPS over a 5-hour period, with measurements taken every 0.625 seconds.

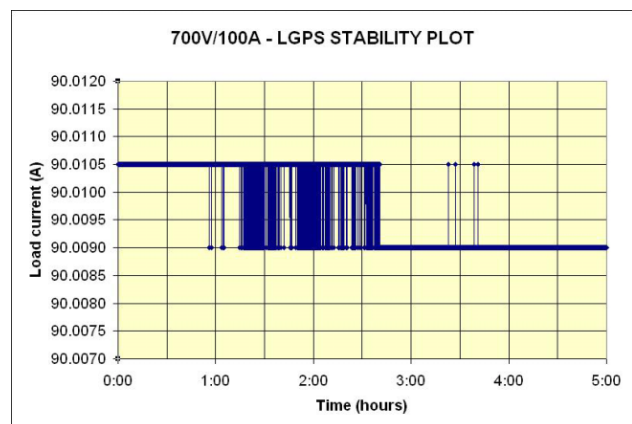

Figure 3: LGPS stability measurements (1div = 5ppm).

The LGPS current stability is provided by the proportional-integral compensation circuit through the Bitbus controller. Values for the gain and time constants were adjusted during the field testing phase using procedures similar to the ones applied to the SPEAR3 intermediate power supplies [7].

It was during the testing phase in the PCD that a key problem was detected with the way the output voltage feedback was designed. According to the manufacturer's original design, an isolation amplifier was used to provide the LGPS output voltage feedback to its internal voltage control loop. This arrangement would ruin the LGPS current stability only under certain output voltages, and the voltage feedback had to be redesigned making use now of a high common-mode voltage difference amplifier.

Installation of the LGPS began in April of 2003. Initial tests and commissioning with the actual load were conducted in December 2003. No major problems have been reported since the LGPS were delivered to SPEAR3 operations in January 2004. Fig. 4 shows an assembly of 4 LGPS inside the SPEAR3 power supply room.



Figure 4: LGPS assembly at SPEAR3.

The LGPS main features are: fast voltage output response, low output voltage ripple content, extensive protection and fault diagnostics system. When operating at rated currents and voltages, the LGPS present a power factor of 0.97, and efficiency of 96%.

Table 2 summarizes the LGPS main operating characteristics in SPEAR3 as of June 2004. In this table, *I-max* is the LGPS maximum current reached during magnet standardization.

Table 2: SPEAR3 LGPS Operating Characteristics.

<i>LGPS System</i>	<i>Volts</i>	<i>Amps</i>	<i>I-max</i>	<i>L/R (s)</i>
MS1-QFC	506	69.1	98	0.30
MS2-QFC	504	69.1	98	0.30
MS1-QF	344	70.7	98	0.27
MS1-QD	206	63.7	98	0.23
MS1-SD	358	136.6	221	0.20
MS1-SF	256	108.9	221	0.18

## ACKNOWLEDGMENTS

The authors would like to thank Mr. David MacNair, from the Engineering and Software Department at SLAC, for his instruction and assistance in developing the successful method [7] of tuning the SPEAR3 power supply current control loops.

## REFERENCES

- [1] R. Hettel, "The Completion of SPEAR 3", EPAC'04, Lucerne, July 2004. These proceedings.
- [2] <http://134.79.112.52:8080/pcd/>
- [3] P. Bellomo et al, "SPEAR3 DC Magnet Power Supplies – An Overview", APAC'04, Gyeongju, Korea, March 2004.
- [4] <http://www.bitbus.org/faq.htm>
- [5] P. Bellomo, "Large Power Supply Performance Specification", Engineering Note SSRL M-370, Rev 1. SLAC internal publication. June, 2001.
- [6] D. Ahronowitz, "Filter Components Cut Emissions and Output Noise", Power Electronics Technology publication, September, 2002.
- [7] P. Bellomo, A. de Lira, "SPEAR3 Intermediate DC Magnet Power Supplies", EPAC'04, Lucerne, July 2004. These proceedings.