

DESIGN ISSUES FOR THE SUPERCONDUCTING MAGNET THAT GOES AROUND THE LIQUID HYDROGEN ABSORBER FOR THE MUON IONIZATION COOLING EXPERIMENT (MICE)

G. Barr, J. H. Cobb, M. A. Green, W. Lau, R. S. Senanayake, H. Witte, and S. Q. Yang, Oxford University Physics Department, Oxford, OX1-3RH, UK; D. E. Baynham, T. W. Bradshaw, P. V. Drumm, J. H. Rochford, and Y. Ivanyushenkov CCLRC/RAL, Chilton, Didcot, OX11-0QX, UK

Abstract

This report describes the design issues that are associated with a superconducting focusing solenoid that goes around a liquid hydrogen absorber for the Muon Ionization Cooling Experiment (MICE) proposed for the Rutherford Appleton Laboratory [1-3]. The solenoid consists of two superconducting coils that may operate at the same polarity or at opposite polarities. As a result, the coils and their support structure must be designed to carry a 360-ton inter-coil force that is forcing the coils apart along their axis. The basic design parameters for the focusing magnet are discussed. The magnet and its cryostat are designed so that the absorber can be assembled and tested before installation into the pre-tested focusing solenoid. Safety requirements for MICE dictate that the insulating vacuum for the superconducting magnet be separated from the insulating vacuum for the absorber and that both vacuum be separated from the experiment vacuum and the vacuum within adjacent RF cavities. The safety issues associated with the arrangement of the various vacuums in the MICE focusing modules are presented. The effect of magnet operation and magnet quench on the liquid hydrogen absorber is also discussed.

INTRODUCTION

Ionization cooling has been selected as a cooling method for muons, because stochastic cooling, electron cooling and laser cooling take a long time (>1 sec) compared to the life of a muon ($2.1 \mu\text{s}$ for a muon at rest). When a muon enters a material, energy is lost along the track. This means that both longitudinal and transverse momentum are lost as the muon passes through the cooling material. If the muon is re-accelerated in the longitudinal direction, the loss of transverse momentum is retained and beam cooling has been achieved. Coulomb scattering of the muon beam in the material counters the effect of cooling. If the emittance lost is greater than emittance gained due to scattering, net ionization cooling results. The ionization cooling equation tells us that an absorber should be located in relatively low beta regions of the cooling channel.

In general, cooling is proportional to the number of electrons in the atom. Coulomb scattering is proportional

to the number of charged nucleons in the atom squared. Thus hydrogen is the best material to use for ionization cooling [4]. As a result, the MICE cooling channel has been designed so that liquid hydrogen absorbers can be installed into the low beta parts of the cooling channel. The lowest beta points within the MICE channel happen to be in the center of a superconducting solenoid that focus the muon beam.

The design of the superconducting solenoid around the MICE absorber is driven by the design requirements of the liquid hydrogen absorber. To further complicate matters, the magnet design must allow the liquid hydrogen absorber to be replaced by a solid absorber at various times during the life of the experiment.

MAGNET REQUIREMENTS DICTATED BY THE LIQUID HYDROGEN ABSORBER

The superconducting focusing solenoid parameters are driven by the interface between the magnet and the liquid hydrogen absorber. This interface is dictated by the following; 1) the beam radius that drives the absorber window size, 2) the length of the absorber, 3) the size of the heat exchanger around the liquid hydrogen in the absorber, 4) the design heat leak into the liquid hydrogen absorber, 5) the ability to replace the liquid hydrogen absorber with a solid absorber, and 6) hydrogen safety issues. The focusing magnet parameters are not affected by the solid absorbers that will replace the liquid absorbers during some parts of the experimental cycle.

The beam size within the absorber is affected by the design momentum acceptance of the experiment and the emittance of the muon beam being cooled. For a cooling channel with reasonable throughput, the radius of the liquid hydrogen windows is set at 150 mm.

The length of the absorber is set by the design energy loss per absorber. For MICE this energy loss is 10 MeV per absorber. This sets the length of the liquid hydrogen absorber at 350 mm, between the thin windows.

The absorbers for MICE do not require a large heat exchanger to get the heat out of the liquid hydrogen, because the beam heating in the MICE absorbers is negligible. The MICE absorber is designed to be identical a liquid hydrogen absorber that can be used in a long cooling channel with intense muon beams. As a result, the MICE hydrogen absorber heat exchanger was

designed to remove up to 200 W from the liquid hydrogen at 20 K [5]. In order to remove heat at this rate, the heat exchanger surface had to be extended. Thus the heat exchanger is about 50 mm thick.

The design static heat leak into the MICE absorbers is set at 12 to 15 W or lower. This heat leak is driven by the desire to cool the absorber with a small cryogenic cooler. The static heat leak includes the radiation heating on the windows as well as radiation heating on the absorber body and pipes and the heat conduction down the absorber cold mass support. The radiation heating on the windows can be more than 10 W unless the windows (MLI) to reduce the heat leak. The MLI on the windows will increase the radiation thickness about 10 percent. One should allow 10 mm of radial space for the MLI.

The MICE design calls for the replacement of an absorber in the cooling channel during a short shut down of ISYS (about 2 weeks). The absorber is designed to be replaced as a unit. The two-week shut down time must include the warm-up and cool down of the hydrogen absorber. The superconducting magnet would be kept at 4.2 K during the shut down.

HYDROGEN SAFETY ISSUES

The biggest driving issue for the design of the absorber focus coil (AFC) module is hydrogen safety. Liquid hydrogen safety dictates the following: 1) The liquid hydrogen absorber must have its own vacuum vessel. The absorber vacuum must not be shared with the vacuum for the superconducting magnet or the vacuum for the rest of MICE. The absorber vacuum vessel should be designed so that no oxygen is frozen onto absorber 20 K surfaces. This means that the absorber vacuum is surrounded by another vacuum or a jacket of argon gas. 2) Because the absorber has its own vacuum, the absorber must have safety windows on that vacuum vessel. The distance between the liquid hydrogen windows and the safety windows should be $>130 \mu\text{m}$. The safety windows must be entirely within the AFC module length. 3) The size of the hydrogen vent pipe is dictated by an accidental rupture of the absorber vacuum vessel that may allow air to condense on the absorber. The film boiling limits the heat transfer into the absorber to about 19 kW. The absorber vent pipe leaving must be sized for a mass flow $>44 \text{ g s}^{-1}$ and a maximum pressure drop to the vent that is $<0.03 \text{ MPa}$. Since the piping must come around the end of the magnet cryostat, this determines the space between the end of the magnet cryostat and the end of the AFC module. The space for the pipes and vacuum vessel at the end of the magnet cryostat is 62 mm. The AFC module length is 844 mm. With the magnet at the center and the AFC, the magnet vacuum vessel length is 720 mm. 4) The final safety issue that effects the design of the AFC module is when the hydrogen window ruptures and the liquid hydrogen boils inside the 300 K absorber vacuum vessel. This case determines the absorber vacuum vessel thickness and the size of the relief system that bleeds

away the hydrogen gas in the event of a window burst. If an absorber hydrogen window breaks, liquid hydrogen spills into the absorber vacuum vessel. The film boiling limits the heat transfer into the liquid hydrogen to about 54 kW. The vent pipes leaving the absorber vacuum space must be sized for a hydrogen gas mass flow of $>116 \text{ g s}^{-1}$ and a maximum pressure drop to the vent that is $<0.03 \text{ MPa}$.

MAGNET DESIGN ISSUES

The inner warm bore radius of the magnet cryostat was set at 235 mm. The outer radius of the AFC matches the RF module outer radius at 707 mm. The maximum allowable length of the cold coil package is 670 mm. This length includes 24 mm thick end flanges. The length of the coils, the space between coils and the coil thickness is set by the peak magnetic induction in the magnet coil at its design current. The MICE focusing coil temperature margin was set at 1.3 to 1.4 K at the design current when the coil temperature is at 4.2 K.

The MICE magnet is designed to operate at 20 percent over its design current (with a 0.4 K temperature margin at 4.2 K). At 20 percent over the design current, the magnetic force pushing coil apart, when the focusing magnet operates in the gradient mode, is 3.52 MN. This force determined the thickness of the coil end plates and the thickness of the 6061-T6 aluminum support structure inside and outside the coils. The final magnet design has a peak stress of 80 MPa in the aluminum at the peak current in the coils. The MICE focusing coil parameters are shown in Table 1 below.

Table 1. MICE Focusing Magnet Parameters

S/C Coil Warm Inner Radius (mm)	263
S/C Coil Warm Thickness (mm)	84
S/C Coil Warm Length (mm)	210
Warm Spacing between the Coils (mm)	200
Number of Coil Layers*	76
Number of Turns per Layer*	127
Magnet Design Current (A)	208.3
Peak Magnet Operating Current (A)	250.0
Self Inductance in Gradient Mode (H)	~ 138
Magnet Stored Energy at design I (MJ)	~ 3.0
Magnet Stored Energy at Peak I (MJ)	~ 4.3
Peak B in Coil at Design Current (T)	6.39
Peak B in Coil at Peak Current (T)	7.67
4.2 K Temperature Margin at Design I (K)	~ 1.4
<u>4.2 K Temperature Margin at Peak I (K)</u>	<u>~ 0.6</u>

* The insulated conductor dimensions are 1.0 by 1.65 mm.

The quench protection system for the MICE focusing solenoids is completely passive. The focusing magnet coils are dependent on warm diodes across the leads and quench back from the winding mandrel for quench protection. During a full current quench, the magnet current decays in about 3 seconds.

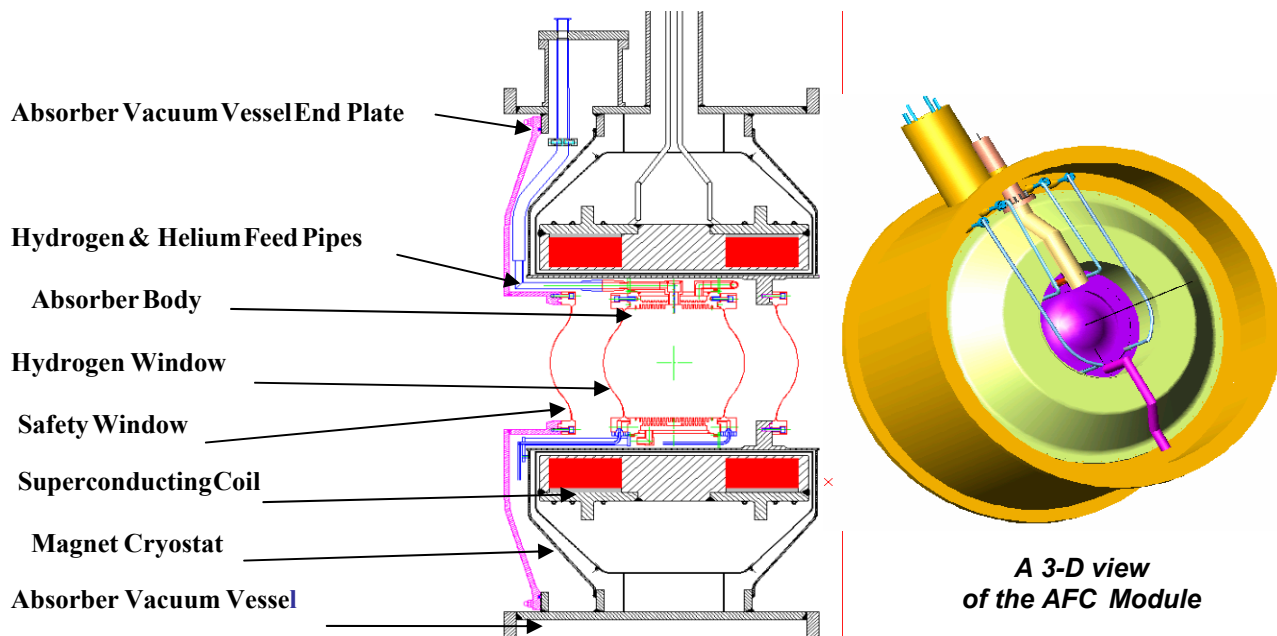

Figure 1. Cross-section View of the Absorber Focus Coil Module showing the Hydrogen Absorber and the Magnet

A quench of the solenoid will induce currents to flow in the 6061 aluminum body of the liquid hydrogen absorber. About 13 kJ of energy is put into the absorber during a magnet quench. This energy can be absorbed by the liquid hydrogen without raising the absorber pressure above its design value of 0.17 MPa. The 130 μm thick aluminum hydrogen and safety windows are unaffected by a magnet quench. The field in the end absorbers is not zero at the center of the end absorbers in MICE. This will induce a small longitudinal force ($<2000\text{ N}$) on the absorber body when the magnet quenches. This longitudinal force must be taken up by the liquid hydrogen absorber cold mass supports.

CONCLUDING COMMENTS

The MICE focusing magnet design is influenced by the liquid hydrogen absorber that is inside the magnet. Hydrogen safety dictates that the magnet cryostat must be completely separated from the hydrogen absorber and its vacuum vessel. The design of the coils is also influenced by the desired field profile within the absorber and the parameters of the superconductor used in the coil. The coil was designed so that the peak field in the superconductor was low enough so that the conductor temperature margin can be at least 1.3 K, when the magnet temperature is 4.2 K. The magnet support

structure is designed to allow it to operate at a current that is 20 percent higher than the design current.

The magnet is designed to quench safely when it is operated at its peak current. The absorber and its hydrogen system will permit the magnet to quench without causing a release of hydrogen from the hydrogen safety relief valves.

ACKNOWLEDGEMENT

This work was supported by Oxford University and the Particle Physics and Astronomy Research Council of the United Kingdom.

REFERENCES

- [1] "A Proposal to the Rutherford Appleton Laboratory, an International Muon Ionization Cooling Experiment (MICE)," proposed by the MICE Collaboration, 15 December 2002
- [2] P. Drumm, "The Muon Ionization Cooling Experiment: Implementation at the Rutherford Appleton Laboratory," Paper MOPLT105, These Proceedings (2004)
- [3] M. Ellis, "MICE: the International Muon Ionization Cooling Experiment," Paper MOPLT106, These Proceedings (2004)
- [4] D. M. Kaplan, "MuSat and MICE Experimental Verification of Ionization Cooling Techniques," presented at the First International Neutrino Factory Summer Institute, Cosner's House, Abingdon UK 29 June 2003
- [5] S. Ozaki, R. B. Palmer, M. S. Zisman and J. Gallardo Eds, "Feasibility Study II of a Muon Based Neutrino Source," BNL-52623, June 2001