

POSITRON SOURCE OPTIONS FOR LINEAR COLLIDERS

K. Floettmann, DESY, 22607 Hamburg, Germany

Abstract

A common feature of future linear collider designs is the requirement of a huge number of particles which have to fit into the acceptance of the damping ring. The requirements are far beyond the current SLC source at SLAC which is the positron source with the highest intensity operated up to now. In addition the acceptance of the damping rings is in some cases smaller as at the SLC.

Linear colliders work in a burst mode with a large number of bunches in a burst, repeated at a low frequency between 5 Hz and 120 Hz. Hence a high number of bunches has to be produced at the repetition frequency.

A fundamental intensity limit for positron sources is given by thermal stress which is built up in the conversion target due to the energy deposition of the particles. Besides improvements of conventional positron sources, i.e. sources where an electron beam creates electron positron pairs in an electromagnetic cascade, new concepts based on the direct conversion of gamma radiation offer possibilities for increased particle intensities. In these sources the hard gamma radiation has to be produced either in an undulator or by backscattering of laser light off an electron beam. An additional advantage of gamma radiation based sources is the possibility to produce polarized positrons.

BASIC CONSIDERATIONS

Positrons have to be produced from photons of some MeV energy by means of pair production in the field of a nucleus in a production target. The straight forward method to produce the required photons is based on bremsstrahlung from electrons passing through the same target. Other methods utilize undulator radiation from an electron beam of ≥ 150 GeV or Compton scattering of laser photons off an electron beam. In case of bremsstrahlung a full electromagnetic cascade develops in a rather thick target, while in case of the direct conversion of photons a rather thin target is required.

Bremsstrahlung and pair production are essentially inverse processes; hence they can be characterized by a common parameter, the radiation length X_0 . It is convenient to measure the target thickness in terms of the radiation length, because for important electromagnetic processes (bremsstrahlung, pair production but also multiple scattering) some or all of the dependence upon the medium is contained in the radiation length. Roughly speaking materials with a high nuclear charge Z have short radiation lengths, while low Z materials have a long radiation length. Conventional positron sources require targets of 4-6 radiation length, while positron sources based on direct photon conversion require targets of only 0.4-0.5 radiation length.

Besides bremsstrahlung and pair production the shower

development is influenced by many other processes like Compton scattering, Møller scattering, Bhabha scattering, photo-effect.

	rep. rate [Hz]	# of bunches per pulse	# of positrons per bunch	# of positrons per pulse
TESLA	5	2820	$2 \cdot 10^{10}$	$5.6 \cdot 10^{13}$
NLC	120	192	$0.75 \cdot 10^{10}$	$1.4 \cdot 10^{12}$
SLC	120	1	$5 \cdot 10^{10}$	$5 \cdot 10^{10}$

Table 1: Parameters of planned and running positron sources.

Linear collider require 10^{12} - 10^{13} positrons per RF pulse (Table 1); thermal stress in the target has to be kept under control in order to avoid target damage.

The heating of the target is dominated by the ionization losses of electrons and positrons given by $E_{dep} \sim 2$ MeV cm^2/g per charged particle. Thus the temperature rise of the target ΔT can be estimated as:

$$\Delta T = 2N\eta \frac{E_{dep}}{c \cdot A}$$

c = heat capacity

A = source area

In order to get N positrons, $2 \cdot N \cdot \eta$ particles (electrons and positrons) have to emerge from the target. The factor η describes the overproduction which is necessary to compensate for the limited efficiency of the capture optics behind the target. The length of the RF pulse of a linear collider is too short to allow for significant thermal diffusion within a burst; hence N is, without countermeasures, the integrated number of positrons required in a pulse. The heat load of the target is determined by three more or less free parameters:

- The number of positrons penetrating through the source area N/A .
- The efficiency of the capture optics $1/\eta$.
- And the heat capacity of the target material c .

An increased source area counteracts a high capture efficiency, because the phase-space density of the emerging positrons is reduced, thus a small source area is favorable. In case of a rather long RF pulse (\sim ms), as it is typical for a superconducting approach (TESLA), the ratio N/A can be improved by a factor of >10 by means of a rotating target [1]. The short pulses of normal conducting approaches (\sim 300 ns) can be distributed onto several targets by means of RF deflectors as proposed for the conventional NLC positron source (Figure 1).

The capture efficiency of the optics behind the target is determined by the emittance of the positron beam and the acceptance of the optics. The bottleneck in the acceptance is however not the optics behind the target but the damping ring. Since linear collider require very small

emittances to reach their luminosity goals the damping rings have in general a relatively small dynamic aperture. In order to increase the acceptance for the positron production a predamping ring, with a large dynamic acceptance and intermediate equilibrium emittance is proposed in conjunction with conventional positrons sources (NLC, GLC).

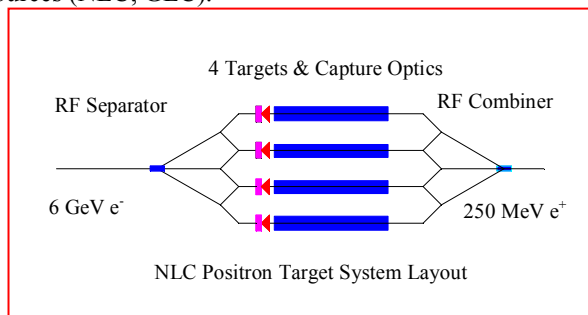

Figure 1: The NLC positron source with RF separators and combiners. 3 targets are used during normal operation; the fourth is a spare target.

The emittance of the positron beam emerging from the target is determined by the source size and the beam divergence. The large divergence of the positrons is generated by multiple scattering in the target, while the source size is influenced by both, multiple scattering and the size of the incoming electron or photon beam. Multiple scattering plays however a much stronger role in the thick target of a conventional positron source than in the thin target of a source based on the direct conversion of photons.

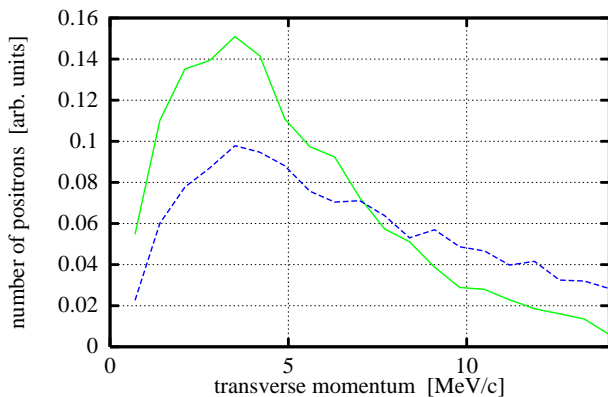

Figure 2: Comparison of transverse momenta of a conventional positron source ($6 X_0$, W, blue) and a thin target driven by undulator photons ($0.4 X_0$, Ti, green).

As a result of the narrower transverse momentum distribution (Figure 2) the phase-space density is higher in the case of a thin target source and the capture efficiency is increased by a factor of ~ 5 compared to a conventional source with the same acceptance of the capture optics.

Low Z materials have in general a higher heat capacity than high Z materials (Dulong Petit Rule). Concerning the heat load low Z materials are hence preferable as target material. The positron production efficiency is however higher in high Z materials. This is due to the fact that the creation of particles in electromagnetic cascades

(bremsstrahlung and pair production) scales with the radiation length, while the dominant energy loss mechanism (ionization loss) scales with the density of the material. The escape depth S_{Escape} from which a positron of a given energy E_{pos} can reach the target surface is estimated as ($\rho =$ density of the material):

$$\frac{S_{Escape}}{X_0} = \frac{E_{pos}}{E_{dep} \cdot \rho \cdot X_0}$$

$$E_{dep} = 2 \frac{\text{MeVcm}^2}{g}$$

Table 2: Escape depth for 10 MeV positrons for various materials.

Material	Z	S_{Escape}/X_0
W	74	0.74
Cu	29	0.39
Ti	22	0.31
Al	13	0.21

Table 2 collects the escape depth in units of the radiation length for 10 MeV positrons for various materials. When the required target thickness is of similar order as the escape depth for typical particle energies the positron production efficiency is less depended on the material properties.

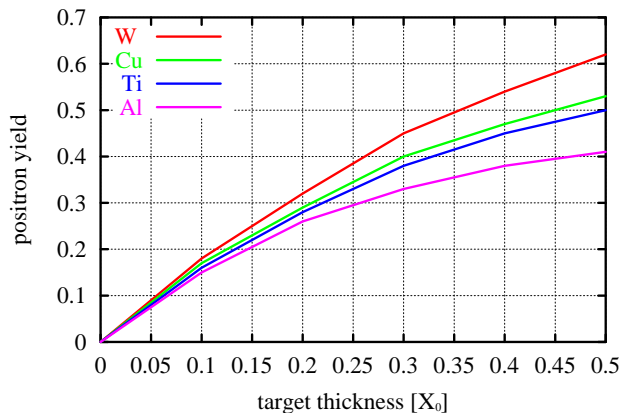

Figure 3: Positron yield for different materials as function of the target thickness. The incoming photon beam was in this example generated by a 250 GeV electron passing through a 1 m long wiggler of 1.7 T field strength.

Figure 3 shows the positron yield as function of the target thickness for the case of a source based on the conversion of undulator photons. At the optimum target thickness of $0.4 X_0$ the yield for a low Z material as Ti is only about 16% below the yield of an equivalent W target. (The optimum target thickness is somewhat before the maximum yield, since the capture efficiency decreases with target thickness.) Hence low Z materials with high heat capacity can be employed in sources based on the direct conversion of photons, while conventional positron sources require high Z materials. The gain in the heat capacity is about a factor of 4.

Target material

A high heat capacity of the target material reduces the temperature rise for a given energy deposition. A locally increased temperature is accompanied by mechanical stress which may lead to cracks and a destruction of the target. Hence a combination of high heat capacity and mechanical constants like a low coefficient of thermal expansion and a high ratio of yield strength to elastic modulus are requested for a target material.

Prime materials under consideration is a Tungsten-Rhenium alloy [2] as high Z material and different Ti-alloys [3] as low Z material. Tungsten-Rhenium has been used as target material in the SLC source, while Ti-alloys are widely used in collimators and exit windows.

An important aspect is the radiation hardness of the target material, since a large number of neutrons are produced in the target. While sufficient material data concerning radiation hardness exist for Tungsten-Rhenium [4] the data basis for Ti-alloys is incomplete. Material tests are in preparation at BNL in a collaborative effort of SLAC and others.

Capture Optics

Particles emerging from the target have to be accelerated in cavities embedded in a focusing solenoid, because they have a broad distribution of transverse momenta. Only a small fraction of the positrons fits into the transverse acceptance of the optics, which is matched to the acceptance of the damping or predamping ring. Therefore the emittance and the efficiency of the of the positron source are defined here. In order to match the phase-space of the positron beam, characterized by a small spot size and a large divergence, to the acceptance of the solenoid which is determined by a large spot size and a small divergence a matching section is introduced between the converter target and the first accelerating cavity. The matching section consists of a so-called Adiabatic Matching Device (AMD), a tapered solenoid starting with a high initial field which tapers adiabatically down to the constant end field.

Besides the acceptance of the damping ring, which defines the useful acceptance of the capture optics, two mechanisms lead to additional particle losses of the positron beam in the matching device:

- Emittance growth due to non adiabatic fields.
- Bunch lengthening due to path length and velocity differences of low energy particles.

R. Helm has found a solution for the particle motion in an adiabatically varying solenoid field [5] from which he derived the optimum on-axis field distribution for the matching device as:

$$B(z) = \frac{B_i}{1 + g \cdot z}$$

B_i = initial solenoid field

g = taper parameter

z = longitudinal coordinate

The condition for an adiabatic field variation is then given as:

$$\frac{g \cdot P}{e \cdot B_i} \ll 1$$

P = particle momentum

e = charge of a positron

In order to fulfill the condition for an adiabatic field for particles with higher energy the taper parameter g has to be small. However, this means that the matching section becomes long and that the bunch lengthening becomes stronger. With B_i in the order of 7 T an optimum is reached at $g = 60 \text{ m}^{-1}$ for conventional sources and $g = 30 \text{ m}^{-1}$ for sources based on the direct conversion of photons.

The acceptance of a cavity section embedded in a solenoid is given as [1]:

$$A_{x,y} = \frac{e}{m_0 c} B \cdot R^2$$

B = solenoid field

R = iris radius

The cavity acts as collimator and has to be normal conducting. Low frequency structures (L-band) offer a large iris radius R and a large acceptance in the longitudinal phase-space. Therefore an L-band positron linac is proposed up to the predamping ring also for NLC and GLC. The solenoid extends over some 10 m in length and reaches field values in the order of 0.1-0.6 T.

After acceleration to energies of 150-200 MeV the positrons are separated from the electrons and the photons in a magnetic chicane. Here additional transverse or longitudinal collimators can be located to clean up beam tails. The electron and the remaining photon beam are dumped and the positron beam is accelerated to its final energy and transferred to the damping ring. Typical overall capture efficiencies are in the 10-20% range.

SOURCE CHARACTERISTICS

The capture efficiency and the emittance of the positron beam depend on some basic design criteria of the source:

- The source size and the transverse momenta of the positrons emerging from the target (i.e. conventional source or source based on photon conversion).
- The acceptance of the capture optics (i.e. predamping ring or no predamping ring).

The transverse and longitudinal phase-space distributions of a positron beam are however to some extend independent of the detailed design of a positron source and exhibit some general characteristics.

Figure 4 shows an example of the longitudinal distribution of the positrons behind the capture optics. While the core of the distribution represents the incoming electron beam a long tail has been developed due to bunch lengthening effects. The positrons in the tail would be lost in the damping ring since the curvature of the RF

leads to a large energy deviation of these particles. Therefore it is desirable to collimate the bunch already at low energy in a special dispersive collimation section.

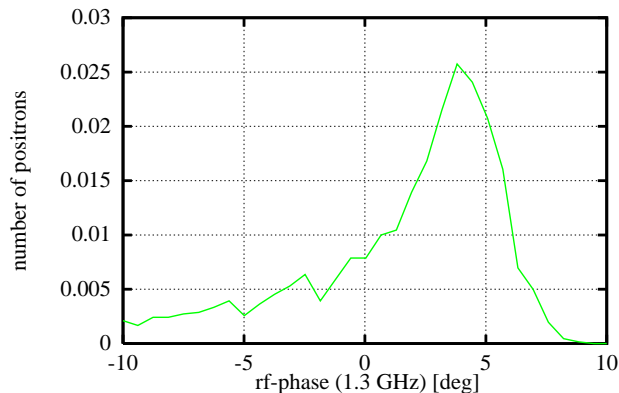

Figure 4: Longitudinal beam profile behind the capture optics. The long tail is due to bunch lengthening in the matching device and consists of low energy particles.

Figure 5 shows the energy distribution of the positrons as they emerge from the target and the fraction of captured particles for an optimized optics. The pile-up of particles at ~5 MeV, as well as the cut-off at ~2 MeV is caused by the energy loss of the particles. The ionization loss increases drastically for particle energies below ~2 MeV.

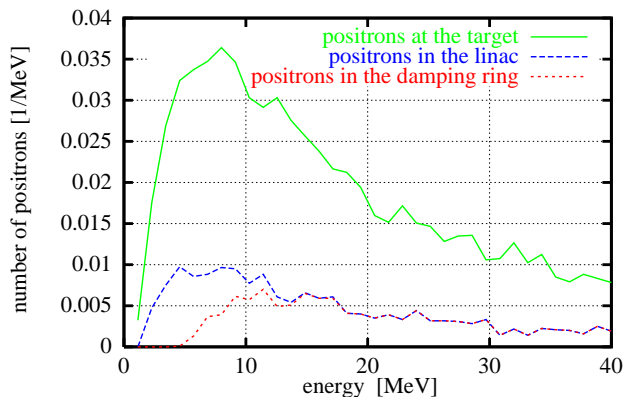

Figure 5: Energy distribution of positrons at the target (green), in the linac (blue) and in the acceptance of the damping ring (red).

The capture optics accepts particles within a broad energy range from 0 up to some 50 MeV, low energy particles should however be collimated as mentioned before.

Even though the beam is collimated with a hard edge the transverse distribution peaks in the center and can be approximated by a Gaussian as shown in Figure 6. This is due to the fact that the collimating aperture is embedded in a solenoid field. The particles move on spiral trajectories and particles in the center have a much higher probability to survive than particles at the edge of the distribution.

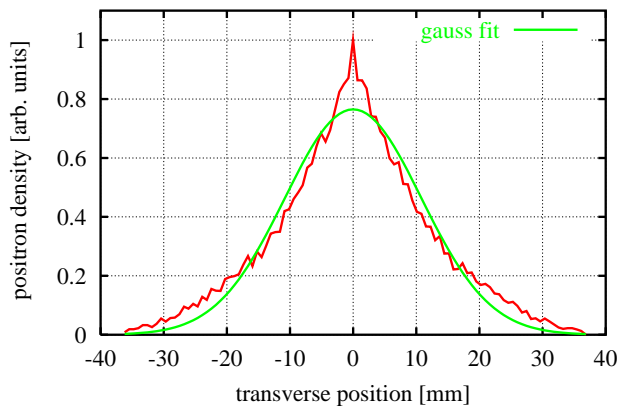

Figure 6: Beam profile behind the capture optics.

POLARIZED POSITRON SOURCES

Polarized positron sources gain increasing attention in the high energy community [e.g 6]. The basic process utilized in a polarized positron source is the transfer of the circular polarization of the incoming photon into longitudinal polarization of the outgoing positron in the pair production process [7]. Figure 7 shows the longitudinal polarization of the outgoing positron as function of its fractional energy for a fully polarized incoming photon. The high energy positrons carry the polarization of the incoming photons while the low energy positrons have a negative polarization. However, most of the low energy positrons will be stopped in the target due to ionization losses. The low energy parts of the spectrum will be repopulated via bremsstrahlung processes. The polarization spectrum of the positron source is hence dominated by the bremsstrahlung process which is shown in Figure 8.

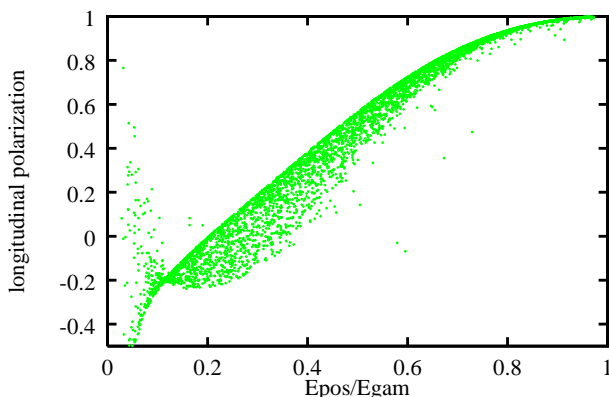

Figure 7: Longitudinal polarization of positrons produced by pair production as function of the fractional energy. The incoming photon is fully circular polarized.

In order to take care of all processes in the shower, polarization states have been included into Monte-Carlo codes like EGS4 [1] and Geant [8].

For the production of polarized photons with energies above 10 MeV two methods have been proposed: Radiation from a helical undulator and backscattering of laser light off an electron beam.

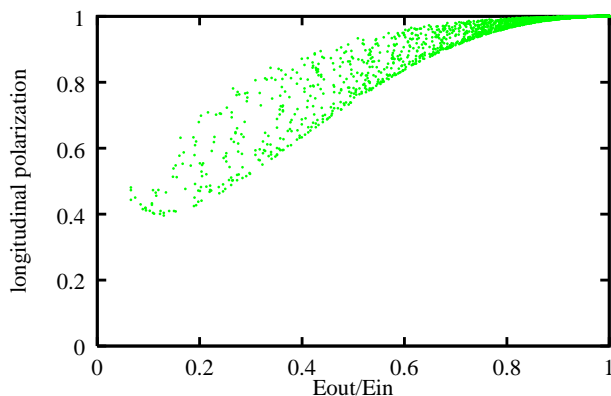

Figure 8: Longitudinal polarization of positrons after bremsstrahlung process as function of the fractional energy.

Photon production with an undulator requires electron energies ≥ 150 GeV, and an undulator with short period (~ 10 mm) of at least 100 m length. The required undulator parameters are challenging; development work is ongoing e.g. at Daresbury. Figure 9 shows the prototype model of a superconducting design.



Figure 9: Prototype model of a superconducting undulator for a polarized positron source (Daresbury).

The on-axis photons of helical undulator radiation are completely circularly polarized; off-axis photons have a lower polarization and a lower energy. Hence the polarization of the photon beam and the produced positron beam can be increased by scraping off-axis photons off.

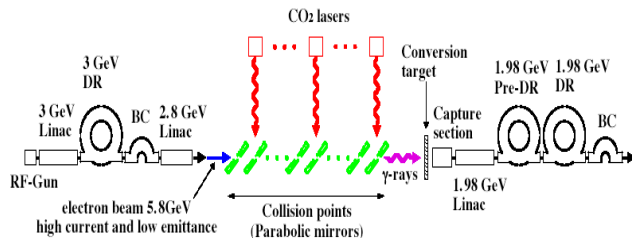

Figure 10: Proposed layout for the polarized positron source for GLC.

Equivalent radiation properties are obtained by Compton backscattering. Figure 10 shows the proposed layout for the polarized positron source for GLC [8]. The circularly polarized photons of 10 CO₂ Lasers are brought into collision with a 5.8 GeV high current, low emittance electron beam, in order to produce the required number of polarized positrons.

The expected polarization reaches in both cases, photon generation with helical undulator or with Compton backscattering, values of 50-60%.

Demonstration Experiments

In order to demonstrate the feasibility of polarized positron sources the E-166 experiment is in preparation in the frame work of an international collaboration at SLAC. A similar experiment based on Compton backscattering is being conducted at KEK [9]. The E-166 collaboration utilizes the 50 GeV beam in the Final Focus Test Beam area. The beam will be passed through a 1 m long undulator to generate photons of energies up to 10 MeV. The pulsed undulator has a period length of only 2.4 mm and an inner diameter of 0.9 mm. The photons are converted into positrons in a thin target. The generated positrons will be guided through a spectrometer and reconverted into photons. The polarization of the reconverted photons finally will be measured in a transmission polarimeter. This challenging experiment is in the design and construction phase, first data taking is scheduled for October this year, followed by a second run in February 2005.

ACKNOWLEDGEMENT

I would like to thank John Sheppard (SLAC), Tsunehiko Omori (KEK) and Duncan Scott (Daresbury) for providing figures and information.

REFERENCES

- [1] K. Flöttmann 'Investigations Toward the Development of Polarized and Unpolarized High Intensity Positron Sources for Linear Colliders', DESY 93-161, 1993.
- [2] W. Stein, et al. 'Stress Analyses for the NLC Positron Target', SLAC-TN-03-044, 2002.
- [3] W. Stein, J. Sheppard 'Structural Modeling of Tesla TDR Positron Target', SLAC-TN-03-043, 2002.
- [4] M.-J. Caturlaet al. 'Radiation damage induced by GeV electrons in W-Re targets for next generation linear colliders', SLAC-PUB-10194, 2002.
- [5] R. H. Helm, 'Adiabatic Approximation for Dynamics of a Particle in the Field of a Tapered Solenoid' SLAC-4, 1962.
- [6] G. Moortgat-Pick, H. Steiner 'Physics opportunities with polarized e- and e+ beams at TESLA', DESY-00-178, 2001.
- [7] V. Balakin, A. Mikhailichenko 'The Conversion System for obtaining high polarized electrons and positrons, Preprint INP 79-85, 1979.
- [8] H. Hoogduin, 'Electron, Positron and Photon Polarimetry', Ph. D. Thesis, Univ. Groningen, 1997.
- [9] T. Omori et al. 'Design of a polarized positron source for linear colliders', NIM A 500, 2003.
- [10] M. Fukuda et al. 'Polarimetry of Short-Pulse Gamma Rays Produced through Inverse Compton Scattering of Circularly Polarized Laser Beams', Phys. Rev. Let. 91, No 16, 2003.