

GENERATION OF A FEMTOSECOND ELECTRON BEAM FOR NANOSCIENCE AND NANOTECHNOLOGY

J. Yang[#], T. Kozawa, Y. Yoshida, S. Tagawa The Institute of Scientific and Industrial Research, Osaka University,
8-1 Mihogaoka, Ibaraki, Osaka 567-0047, Japan

Abstract

A new S-band femtosecond electron linear accelerator was developed in Osaka University for the study of radiation-induced ultrafast physical and chemical reactions in nanoscience and nanotechnology by means of pulse radiolysis. The femtosecond electron linear accelerator was constructed with a laser driven photocathode RF gun, a linear accelerator (linac) and a magnetic pulse compressor. A picosecond electron pulse was produced from the photocathode RF gun, accelerated by the linac with energy modulation, and finally compressed into femtosecond by the magnetic pulse compressor. The laser injection phase of RF gun, the magnetic field of single emittance compensation, and the RF phase of the linac were optimized by PARMELA simulation with space-charge calculation. The positioning of magnets in the pulse compressor was done by TRACE-3D calculation. As a result, an electron pulse of about 20 fs with energy of 35 MeV and pulse charge of 0.2 nC was observed after the pulse compression.

INTRODUCTION

Development of a pump-probe measurement technique in the femtosecond or attosecond scale is important for the study of a dynamic process involving the mechanical motion of electrons and atomic nuclei in physics, chemistry and biology. A pulse radiolysis, which is pumped by an ultrashort electron beam and analyzed by an ultrashort light, is a powerful tool for the observation of ultrafast electron-induced phenomena in materials, such as ionization, excitation, relaxation, electron transformation and so on. The time resolution of the pulse radiolysis has reached to picosecond by using a picosecond electron pulse. In Osaka University, a subpicosecond pulse radiolysis with a time resolution of 800 fs was developed by using a femtosecond electron pulse produced in an L-band linear accelerator, an analysis femtosecond laser light, and the time jitter compensation between the electron pulse and the laser light[1,2]. Recently, a new femtosecond pulse-radiolysis system with a time resolution of <100fs was developed in Osaka University[3].

However, in order to achieve such time resolution, the developments of the three technologies are required: (1) an ultrashort electron pulse, (2) an ultrashort analysis light source, and (3) precise synchronization between the electron pulse and the analysis light. To solve these problems, a laser-driven photocathode RF gun based linear accelerator was constructed to produce such short

electron pulse. It was known that the efficiency of charged particle pulse compression depends on the beam quality. The photocathode RF gun produces a low emittance short-bunch electron beam, such as <1 mm-mrad at 3 ps[4,5], resulting in an effective pulse compression into femtosecond. Another advantage by using the RF gun is easy to synchronize the laser light with the electron pulse.

EXPERIMENTAL ARRANGEMENT

Photocathode RF Gun and Laser

Figure 1 shows the femtosecond electron pulse generation system. A 1.6-cell S-band (2856MHz) RF gun, produced by Sumitomo Heavy Industries (SHI)[4,5], was used in the system. The RF gun was composed of two cells: a half cell and a full cell. The length of the half cell was designed to be 0.6 times the full cell length to reduce the beam divergence. The coupling between the waveguide and cavity was located in the full cell. Coupling between the cells was accomplished via the iris of the cavity. The copper cathode used in the system was located on the side of the half cell. A single solenoid magnet was mounted at the exit of the RF gun to compensate the space charge emittance. The cathode magnetic field was measured to be less than 10G at a peak magnetic field of 3kG, resulting in a negligible emittance growth due to the cathode magnetic field.

The RF gun was driven by an all solid-state LD-pumped Nd:YLF picosecond laser. The laser consisted of a laser oscillator, a regenerative amplifier, and a frequency converter. The oscillator was mode-locked with a frequency of 79.3MHz, the 36th sub-harmonic of the 2856MHz accelerating RF, by adjusting the cavity length of the oscillator with a semiconductor saturable absorber mirror (SESAM). The time jitter between the oscillator output and the reference 79.3 MHz RF signal was measured to be <0.5 ps using a phase detector technique. After the oscillator, a Pockels cell captured a single oscillator laser pulse to amplify the pulse energy up to about 2 mJ in the regenerative amplifier. The repetition rate of the regenerative amplifier is 30 Hz in the maximum. The amplified pulse was frequency quadrupled to a 262 nm ultraviolet (UV) light with maximum pulse energy of 0.3 mJ using a pair of nonlinear crystals. The UV light was injected on the cathode surface at an incident angle of approximately 2° along the direction of the electron beam using a prism placed downstream of the gun, as shown in Fig.1. The diameter of the beam size at the cathode surface was 3 mm. The pulse width of the UV

[#]yang@sanken.osaka-u.ac.jp

light was measured to be 5 ps (FWHM), as shown in Fig. 2, by a streak camera with a time resolution of 200 fs.

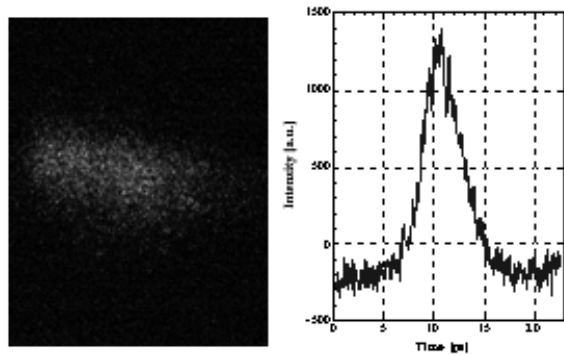

Figure 2: The UV light pulse measured by a femtosecond streak camera

Linear Accelerator and RF source

The electron beam produced by the RF gun was accelerated with a 2 m long S-band travelling-wave linear accelerator (linac). The linac was located at a distance of 1.2m from the cathode surface. The energy of the electron pulse was also modulated by adjusted the RF phase for pulse compression, as described below. The operating temperatures of the RF gun and the linac were 32°C and 30°C, respectively. The temperature fluctuation of both the RF gun and the linac were within 0.1°C.

The peak RF inputs of the RF gun and the linac were 10 MW and 30 MW, respectively, which was produced by a 40 MW Klystron. The stability of the RF power was 0.1% peak-to-peak. The effective pulse width of the RF was 4 μ s. The peak on axis electric fields in the RF gun and the linac were approximately 100 and 20 MV/m, respectively. The repetition rate of the operation was 10 Hz in the experiment. A high-power phase shifter installed in a 30 MW RF line, as shown in Fig. 1, was used to adjust the RF phase of the linac for energy modulation.

Magnetic Pulse Compressor

The magnetic pulse compression, which was constructed with two 45°-bending magnets and four quadrupole magnets, is a technique to longitudinally focus a charged beam by rotating the phase space distribution in a magnetic field. The picosecond electron pulse generated in the RF gun and accelerated in the linac with energy modulation is compressed into femtosecond by adjusted the magnetic fields of the quadrupole magnets.

The positioning of magnets in the pulse compressor was done by TRACE-3D calculation. Furthermore, it is noted that, in order to obtain a femtosecond electron pulse, the generation of a low-emittance electron beam should be important in the system.

Analysis Light Source

A mode-locked Ti:Sapphire femtosecond laser was used as an analysis light source in the pulse radiolysis measurement. The Ti:Sapphire laser oscillator output was phase-locked with the 79.3 MHz RF (the 36th sub-harmonic of the 2856MHz accelerating RF). The femtosecond oscillator light was stretched to 200ps by a pulse stretcher, and amplified the pulse energy up to about 1 mJ in a regenerative amplifier with a Pockels cell. Finally, the laser pulse was compressed into 100 fs by a pulse compressor installed downstream of the amplifier. The repetition rate of the regenerative amplifier is 1 KHz.

Timing Synchronization

Figure 3 shows a block diagram of the timing synchronization between the laser and RF. A RF signal generator supplies a 2856 MHz radio frequency. The RF signal was divided into two: one was used to drive the Klystron, while another is divided in frequency by 36 to 79.3 MHz to drive both the picosecond Nd:YLF laser and the femtosecond Ti:Sapphire laser. A trigger signal generator generates two 1 KHz signals: one is synchronized with the 79.3 MHz RF signal and used for the Ti:Sapphire laser and measurement system (such as a

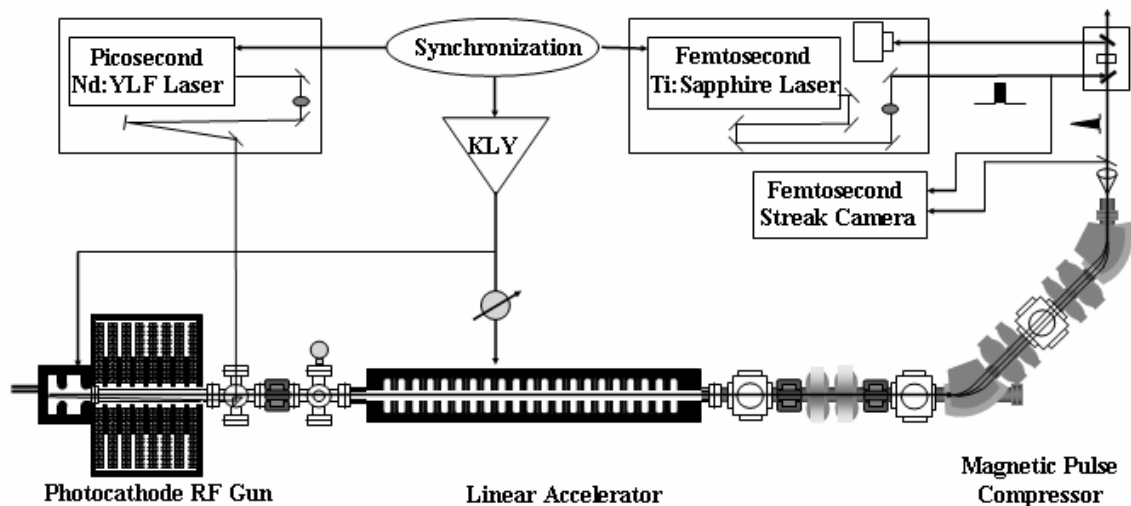

Figure 1: A femtosecond electron linac based on a photocathode RF gun

streak camera), while another is divided to a 10 Hz trigger signal and used for the trigger signals of both the Nd:YLF laser and Klystron. Two low-power phase shifters installed in the 79.3 MHz RF lines are used to adjust both the laser injection phase in the RF gun and the timing of the femtosecond laser light. The time jitter between 2856 MHz RF signal and 79.3 MHz RF signal was measured to be <2 ps by a digital sampling oscilloscope. The time jitter between the RF signal and the trigger signal was measured to be <10 ps.

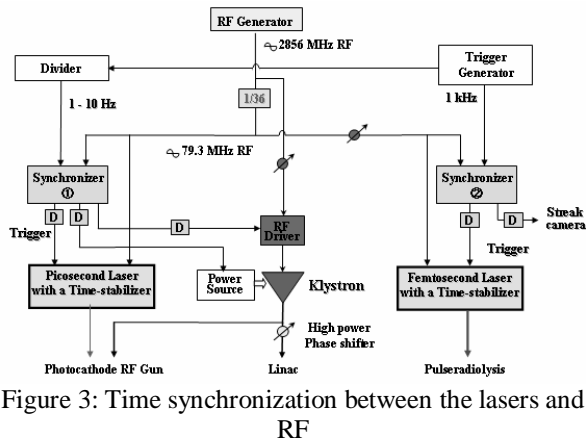

Figure 3: Time synchronization between the lasers and RF

SIMULATIONS

The generation and acceleration of the electron pulse in the RF gun and the linac were simulated by using PARMELA code with a 3D particle-to-particle space-charge calculation. Figure 4 shows the results of the phase-space distributions of the electron beam versus the distance from the cathode. In the simulation, the charge of the electron pulse was fixed to be 0.1 nC. The laser injection phase in the RF gun was 30° from the zero crossing of the RF. The solenoid field was 1.2kG, which was given the best emittance compensation at the bunch charge of 0.1 nC. The RF phase of the linac was 70° to give an optimum energy modulation for the pulse compression. The beam energy was 35 MeV. The simulation indicates that an electron beam at the exit of the linac with a transverse normalized emittance of 0.7 mm-mrad, a longitudinal emittance of 15 KeV-deg and an

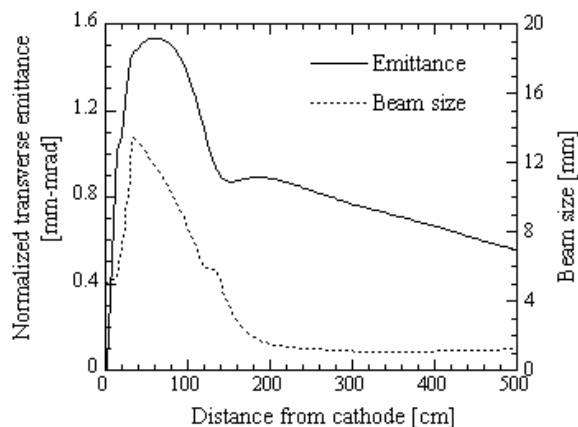

Figure 4: The calculated emittance and beam size

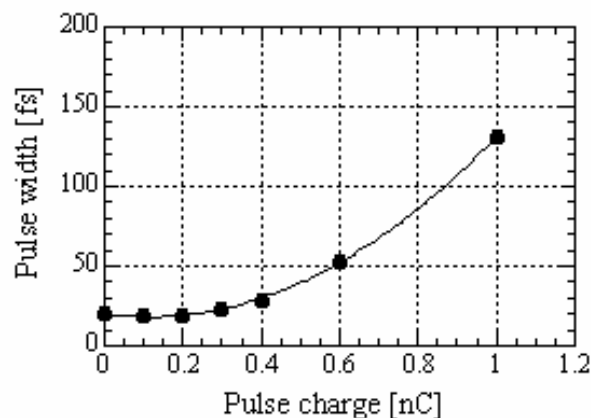

Figure 5: The calculated pulse length versus bunch charge

energy spread of 3-4 % can be achieved at the bunch charge of 0.1 nC.

By using the output of PARMELA as the input of TRACE-3D calculation, we positioned the four quadrupole magnets in the magnetic pulse compressor, and optimized the magnetic fields of the four quadrupole. We obtained the compressed pulse length of the electrons as a function of the bunch charge, as shown in Fig. 5. The data indicated that the minimum rms pulse length of 20 fs is achieved at the bunch charge of <0.2 nC. The pulse length of the electrons increases for the high charge, 130 fs for 1.0 nC.

CONCLUSIONS

An S-band femtosecond electron linear accelerator based a laser-driven photocathode RF gun was developed. A magnetic pulse compressor was constructed and positioned by simulation. A 20 fs electron pulse was observed at the pulse charge of <0.2 nC. A timing synchronization system was constructed with an analysis femtosecond laser for applications, such as the measurements of electron-induced ultrafast reactions in materials by means of pulse radiolysis.

However, the simulation of the pulse compression was done with one-order magnetic field effect. High-order effects of the magnetic fields and coherent synchrotron radiation should be considered in the next step for producing an electron pulse in a few tens femtosecond or low.

REFERENCES

- [1] Y. Yoshida, et al., *Radiat. Phys. Chem.*, **60** (2001), 313-318.
- [2] K. Kozawa, et al., *Nucl. Instrum. Meth. A* **440** (2000), 251-254.
- [3] Y. Yoshida, et al., *Proc. of this conference*.
- [4] J. Yang, et al., *J. Appl. Phys.*, **92** (2002), 1608-1612.
- [5] J. Yang, et al., *Nucl. Instrum. Meth. A* **491** (2002), 15-22.
- [6] J. H. Billen, *PARMELA User's Manual*, Los Alamos Accelerator Code Group, LA-UR-96-1835.