

## THE BUNCH COMPRESSOR SYSTEM FOR SIS18 AT GSI

P. Hülsmann, G. Hutter, W. Vinzenz

GSI, Gesellschaft für Schwerionenforschung, Planckstraße 1, D-64291 Darmstadt

### ABSTRACT

For bunch compression down to pulse durations of 50 ns, a dedicated rf system is under development for the SIS 18 heavy ion synchrotron and will be described in this paper [1,2]. The rf system consists of very short cavities inductively loaded by magnetic alloy (MA) ring cores and rf power stages which provide a short rise time. This new rf system will be a prototype for the advanced compression system required for the proposed future facility (FAIR) [3] at GSI.

### INTRODUCTION

The most effective way to produce short ion bunches is the process of fast bunch compression by means of a 90° rotation of the longitudinal phase space ellipse [4]. In contrast to the adiabatic capture process, where the voltage rise time has to be several times the synchrotron period, with fast bunch compression the final voltage has to be reached as fast as possible.

**Table 1:** Beam parameters for bunch compression

Ion species	U <sup>28+</sup>
Energy	200 MeV/u
Revolution frequency	800 kHz
Harmonic number	1
Initial momentum spread	$\pm 4 \cdot 10^{-4}$
Final momentum spread	$\pm 7 \cdot 10^{-3}$
Compression factor	17.5
Initial voltage	1 kV
Voltage during rotation	160 kV

**Table 2:** The proposed parameters for the rf system

Frequency range	0.8-1.4 MHz
Number of gaps	4
Gap voltage	40 kV
Total length for one gap	0.8 m
Shunt impedance without final rf stage	2.0 k $\Omega$ (20 cores per cavity)
Final rf stage	600 kW push pull 2 x RS 2054 SK
Pulse duration	$\leq 500 \mu\text{s}$
Rise time	$\leq 10 \mu\text{s}$
Repetition frequency	1 Hz
Mean power	0.3 kW

After the acceleration process with the higher harmonic ( $h=4$ ), the beam is usually debunched. The first step for

bunch compression is to recapture the beam by switching the rf voltage on, so that the beam is almost completely bunched. Then the rf voltage is increased non-adiabatically and the unmatched beam bunch rotates in the synchrotron phase space. The important beam parameters for bunch rotation are listed in Table 1. Table 2 shows the parameters for the required rf system. Two aspects make the design of the additional compressor rf system very difficult:

1. Due to space limitations in SIS 18, the length of one cavity is limited to 0.8 m.
2. The short rise time  $\leq 10 \mu\text{s}$  (which is very small compared to similar systems).

### METALLIC ALLOY RING CORES

The 0.8 m available length for one cavity is very short. Due to flux density limitations, the 50 kV/m required voltage per unit length cannot be achieved with ferrite materials. The saturation flux density of ferrites, e.g. Ni-Zn (Co) is rather low, with values of the order of 0.01 T, whereas MA cores like the amorphous VitroVAC 6030F, from Vacuumschmelze or the nanocrystalline Finemet FT-3M from Hitachi, can achieve up to 1 T of magnetic flux density. In standard bunch compressor operation the flux density swing is limited to 0.3 T to avoid nonlinearities caused by the hysteresis loop and to reduce magnetostrictive effects.

In contrast to ferrites, the skin depth in magnetic alloys is much smaller than the dimension of the core. The core must therefore be divided into small sections, so that the magnetic field penetrates the material completely. This is accomplished by use of a laminated structure. Thin (15 - 17  $\mu\text{m}$ ) magnetic alloy ribbon is wound on a cylindrical mandrel, with an intermediate layer (1 - 4  $\mu\text{m}$ ) of insulation. The result is a toroidal core.

**Table 3:** Parameters for the MA-ring core material

Operating frequency $f_0$	800 kHz
Relative permeability $\mu_r$	2700
Conductivity of the ribbon $\sigma$	$0.77 \cdot 10^6 \text{ 1}/\Omega\text{m}$
Width	25 mm
Inner radius $r_i$	145 mm
Outer radius $r_a$	313 mm
Filling factor $\eta_F$	0.71
$\mu_r Q_C f_0$ value	4.3 GHz

In subsequent analysis, we made the assumption that the core is composed of nested cylinders and that there is no radial conduction of real current. In reality, some current

flows from the inside to the outside of the core along a single ribbon. This current is very small since the path has a huge inductance, given that a laminated core contains thousands of turns.



**Fig. 1:** One full size nanocrystalline Finemet FT-3L ring core from Hitachi with a measured  $\mu_r Q_C f_0$  value of 5.3 GHz. On both sides the ring core is covered by a thin resin layer. On the left side one can see a 1:5 sample of a Finemet core, on the right side a 1:5 sample of an amorphous VitroVAC 6030F sample from Vacuumschmelze

materials. For our purposes, the  $\mu_r Q_f$  value should be larger than 3.6 GHz at 800 kHz, but the higher the  $\mu_r Q_f$  value, the better for the compressor project. A ring core performance of 3.6 GHz is usually available on the market at present. Thus, we have started a research program, in collaboration with Metglas Inc. (USA), Vacuumschmelze (Germany), Hitachi (Japan) and the Radio-technical Institute in Moscow (MRTI) to produce core materials and test cores with reduced losses, using different annealing techniques. The dimensions of the test ring cores are scaled down by a factor of 5 (keeping the width of the ribbon at 25 mm) which reduces the price considerably. Furthermore, we are able to test the scaled ring cores at GSI with a realistic level of energy density, at a corresponding power level of 10 kW. As a result of this effort the  $\mu_r Q_f$  values for amorphous ring cores could be increased from 3.6 - to 4.6 GHz for 1:5 samples and for nanocrystalline full size ring cores from 3.6 - to 5.3 GHz (A full size Finemet ring core, which is one of twenty delivered ring cores from Hitachi, is shown in Fig. 1). This was achieved by different measures, for example the reduction of the ribbon thickness, the increase of the filling factor and last but not least the improvement of the production techniques. A comparison of  $\mu_r Q_f$  values achieved at different projects is shown in Table 4. The numbers in Table 4 were taken from papers about the respective projects.

**Table 4:** Comparison of  $\mu_r Q_f$  values achieved at different projects

Project	Frequency [MHz]	$\mu_r Q_f$ [GHz]
KEK Conceptual Cavity Design	0,1-10	1,9
JHF Cavity	2-3,5	3,0
FNAL Test Cavity	6,638-7,368	3,0
FNAL Test Cavity (Barrier Bucket)	2,0	3,0
FNAL Bunch Coalescing Cavity	7,170-7,586	2,7
Hitachi Testcavity I	0,5-10	3,8
HIMAC High Gradient Cavity (HGC)	1-8	3,2
Test cores 1:5 from Metglas Inc. (amorphous)	1,0	4,6
Test cores 1:5 from Vacuumschmelze (amorphous)	1,0	4,6
Full size cores from Hitachi (nanocrystalline)	1,0	5,3

Due to the length limitation of the cavity and in order to keep the power requirements as low as possible, a specific level of core performance (see Table 3) is required. The core performance is described by the so called  $\mu_r Q_f$  value, which is often used as a figure of merit for MA and ferrite

## THE CAVITY

One cavity consists of two  $\lambda/4$  coaxial cavities, working in push pull mode on a ceramic gap. Resonance at the fundamental frequency is set by two 1 nF adjustable capacitors. Only the stainless steel beam pipe and the gap ceramic are under vacuum, the remaining cavity being operated in air. A schematic view of the wideband cavity is shown in Fig. 2.

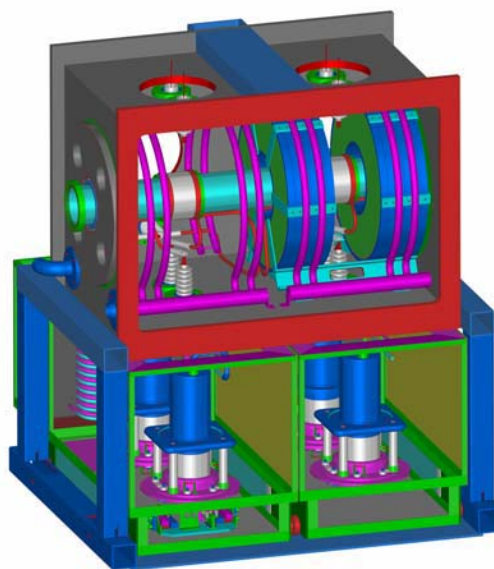

**Fig. 2:** Two cavities are combined in one box. The rf power stage is located directly below the cavity box.

Each cavity (Fig. 2) is filled with 20 ring cores. In order to have the opportunity to test two different ring core types, one gap is filled with 20 VitroVAC 6030F whereas the other gap is filled with 20 Finemet FT-3M ring cores. The cores are mechanically stabilized by a thin resin layer, which provides also a thin side wall covering. Two cores are combined as pairs and air cooling is provided by a space of 6 mm between adjacent pairs. This space is adequate for cooling at the low average power of 300 W. The ring cores are attached via an isolator to six support bars which also form the outer conductor of the coaxial cavity. The inner support rings are electrically connected to the beam pipe.

Due to the required short rise time of the rf system the final stage is located directly below the cavity. During the non operation time between two accelerating cycles, it is planned to decrease the gap impedance of the compressor cavities below  $10 \Omega$  using fast MOS FET switches. When the bunch compressor system is not needed for many cycles, the gaps will be shorted by vacuum switches.

### THE FINAL RF STAGE

A prototype rf power stage is presently being available at GSI. A schematic view of the rf power stage and the cavity is displayed in Fig. 3. The rf power is generated by two Siemens RS2054SK tubes operating in push pull mode. During the rf pulse, both tubes will be set from C- into A-operating point by a common switched grid-voltage. The final stage is driven by a wide band 1 kW solid state amplifier and the power is transmitted via a ferrite loaded toroidal transformer. The grid voltage is fed to the secondary of the toroidal transformer. A capacitively coupled resistance of  $100 \Omega$  between grid and cathode stabilizes with respect to both tubes in order to avoid self excitation of the final stage. To provide safe operation during the switching time from class C- to class A-mode two grid bleeder resistors of  $20 \text{ k}\Omega$  are connected between grid and ground. Balancing of both tubes can be performed individually by adjusting the voltage of the separated screen grid power supplies.

### THE SUPPLY UNITS

To supply and control the final stage, a so called "supply unit" was already delivered to GSI. All electronic components are installed inside a rack system, including the power supplies for the plates, grids and heaters of the final stage. In addition, the amplitude and phase control units, the analogue measuring and tube protection units, the programmable logic control (PLC), the computer interface, the automatic tuning system, and the driver stage are housed in these cabinets. The timing information for rf pulse width, pulse spacing and sampling time, which is transmitted via a GSI two-wire bus, is decoded in a special timing interface. A careful handling of the fast switching procedures for the gap bypass switches, the C/A-mode control, and the release of the rf pulse is done by an additional electronic board. Due to the low center frequency and the required broad band operation, the present (UNILAC) low level sections as well as the am-

plitude and phase control units had to be redesigned. Presently, one supply unit is ready for operation.

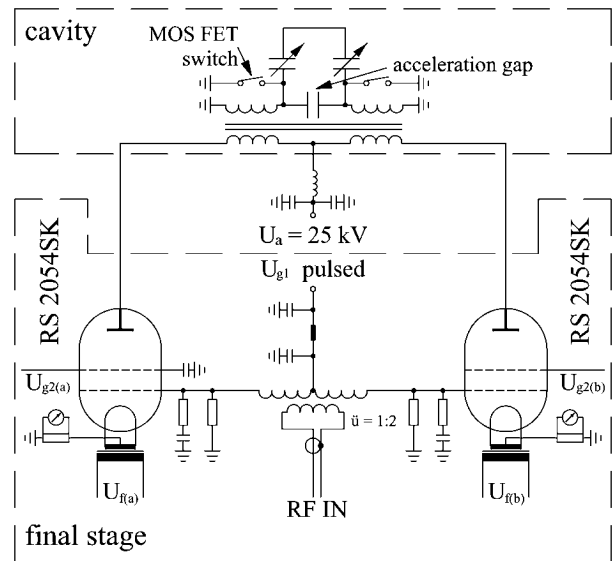

Fig. 3: Schematic view of rf power stage, cavity and fast switches.

### CONCLUSION

The development of appropriate magnetic alloy cores for the compressor project is a challenging task which was worked out in close collaboration with the producers of the magnetic materials. As one can see in Table 3 the ring core performance could be improved by an enormous amount which is an important result particularly with regard to the requirements for the GSI future facility (FAIR) project. The improvements of the ring core performance could be achieved by different measures, for example the reduction of the ribbon thickness, the use of different annealing techniques, the increase of the filling factor and last but not least the improvement of the production techniques.

The design and construction of the power amplifier is finished and the prototype is available now. The construction of the cavity could not yet be finished.

### REFERENCES

- [1] K. Blasche et al., Bunch Compression in the Heavy Ion Synchrotron SIS at GSI. Europ. Part. Acc. Conf., Stockholm, Sweden, 1998, pp. 1347-1349
- [2] P. Spiller et al., Generation of High Power Ion Beams at GSI. Part. Acc. Conf., New York, N. Y., 1999, pp. 1788-1790
- [3] W. Henning, An International Accelerator Facility for Research with Ions and Antiprotons. Europ. Part. Acc. Conf., Lucerne, Swiss, 2004, invited talk, this conference
- [4] S. Y. Lee, Accelerator Physics, World Scientific Publishing Co. Pte. Ltd., 1999