

LARGE SCALE PRODUCTION OF 805-MHZ PULSED KLYSTRONS FOR THE SPALLATION NEUTRON SOURCE PROJECT*

S. Lenci, E. Eisen, CPI, Palo Alto, CA, USA

Abstract

The Spallation Neutron Source (SNS) is an accelerator-based neutron source being built in Oak Ridge, Tennessee, by the U.S. Department of Energy. The SNS will provide the most intense pulsed neutron beams in the world for scientific research and industrial development. CPI is supporting the effort by providing 81 pulsed klystrons for the super-conducting portion of the accelerator. The primary output power requirements are 550 kW peak, 49.5 kW average at 805 MHz, with an electron beam-to-rf conversion efficiency of 65% and an rf gain of 50 dB. Through May 2004, 60 units have been factory-tested. Performance specifications, computer model predictions, operating results, and production statistics will be presented.

INTRODUCTION

CPI, formerly of the Electron Device Group of Varian Associates, has a long history of building high-power pulsed UHF klystrons for many applications. This 550 kW pulsed klystron will be used in the Superconducting linac of SNS, where up to 12 klystrons will be powered from a single power supply. Since the klystrons do not have a modulating anode, the cathode voltage will determine the beam current. The system must accommodate variation in klystron perveance as well as end of life operation. The result is the klystron with the highest cathode voltage requirement will determine the operating level of the entire group of klystrons.

Although the peak and average rf power requirements are fairly modest, the combination of high efficiency (65%) and high gain (50 dB) provided quite a challenge. The constraint on beam operation and microperveance limited design options.

Originally 65 of the 550-kW tube, VKP-8291A, were been ordered. The exercise of options increased the total to 81 units. Through May 2004, a total of 60 units have been factory tested. The contractual delivery rate for the remainder of the contract is 4 per month, with the 81st unit being delivered in October 2004.

DESIGN

The efficiency requirement of 65% was the key concern in the rf design. To achieve this, a six-cavity rf-circuit, including one tuned slightly below the second harmonic of the operating frequency, was chosen. The design is optimized to provide the required efficiency and gain without compromising bandwidth. The first two cavities are staggered around the operating frequency to provide

the bandwidth. Next is the second-harmonic cavity followed by two inductively tuned cavities to optimize the electron bunching. The output cavity then extracts energy from the beam.

The electron gun is a low-perveance, diode design. The voltage gradients of the gun electrodes are less than 60 kV/cm, which will ensure long life for this long pulse device. The peak cathode loading is .6 Amps/cm², which yields a predicted cathode life in excess of 100,000 hours.



Figure 1: VKP-8291A Klystron

The klystron is required to operate vertically with the gun down and is shown Figures 1 and 2.

The rf energy is extracted through a single window with an alumina ceramic. The pillbox window is designed around WR-975 waveguide.

The collector is designed to dissipate the entire beam energy. It is made from a thick-walled copper cylinder with grooves milled into the outer wall for the coolant to pass. The water-jacket is part of the brazed collector assembly. The proof test pressure is 200 psi (13.6 bar).

*Work supported by US Department of Energy

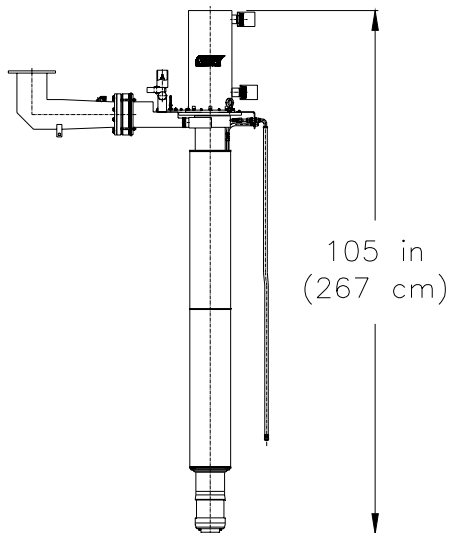

Figure 2: VKP-8291A Klystron Layout

TEST RESULTS

The klystron performance through the production run has been very consistent. See Table 1 for the performance summary.

	VKP-8291A Specification	VKP-8291A Typical
Frequency	805 MHz	805 MHz
Peak Cathode Voltage	75 ± 1.5 kV	75 kV
Peak Beam Current	11.5 Amps max	11.2 Amps
Perveance	.55 nom	.54
Peak Output Power	550 kW min	560 kW
-1 dB Bandwidth	± 1.3 MHz min	± 2 MHz
Efficiency	65 % min	67 %
RF Duty Cycle	9 %	9 %
RF Pulse Length	1.5 msec	1.5 msec
Peak RF Drive Power	5.5 Watts	4.3 Watts
Gain	50 dB min	51dB

Table 1: VKP-8291A Performance Summary

The transfer and bandpass curves of 25 units, along with the simulation predictions, have been plotted together for comparison as seen in Figures 3 and 4. The prototype klystron stands out as the only unit that did not meet the efficiency requirement. Otherwise the variation among the units is quite reasonable. Additionally each klystron has to demonstrate stable performance and achieve 80% of its rated power at six equally spaced positions of a 1.2:1 mismatch.

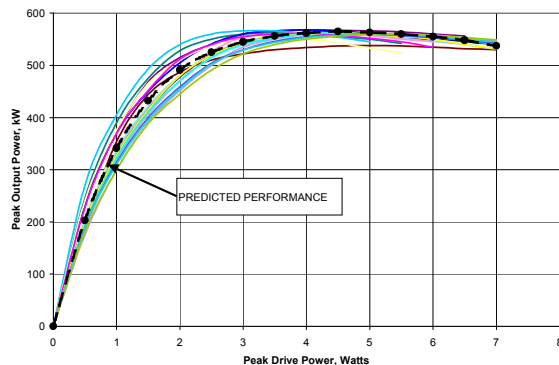

Figure 3: VKP-8291A Transfer Curves

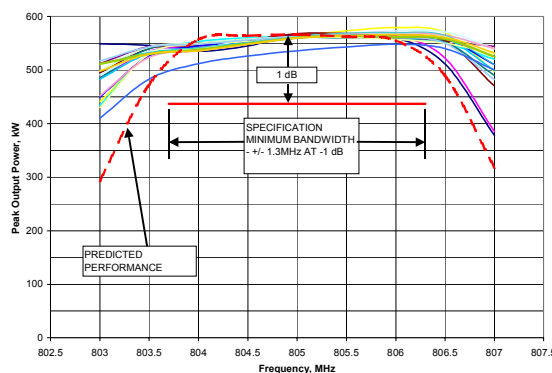

Figure 4: VKP-8291A Bandpass Curves

The Phase Transfer Characteristic (the insertion phase of the klystron) is required to be a smoothly varying, monotonic function as the drive power is increased from 20% to 100% of the saturated drive, and is measured on each unit. The phase shift was measured in 0.5 dB increments as the drive power was reduced from saturated output (0 dB) to -13.5 dB (4.5% of saturated drive), see Figure 5.

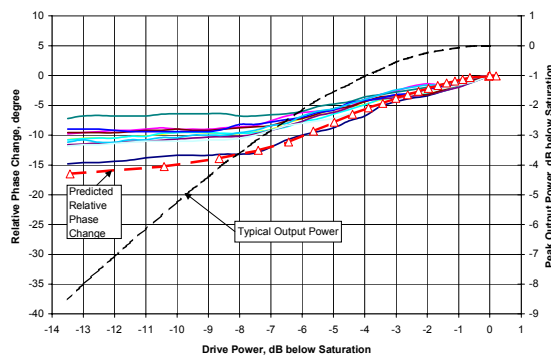

Figure 5: Relative Phase Change vs. Drive Power

PRODUCTION RESULTS

The production rate to support this contract has provided an opportunity to evaluate operational and performance variation. Some of the variation is due to manufacturing tolerances, such as spacing in the gun that directly influence the microperveance, and some are due to optimizing performance at test. The gain and bandwidth are greatly influenced by the cavity tuning. We found if the gain is too high, the tube is much closer to instabilities should the magnet settings or beam voltage drift. Our goal is to set the gain just below 51 dB to provide margin. Figure 6 displays the key performance data through the 60 units tested to date.

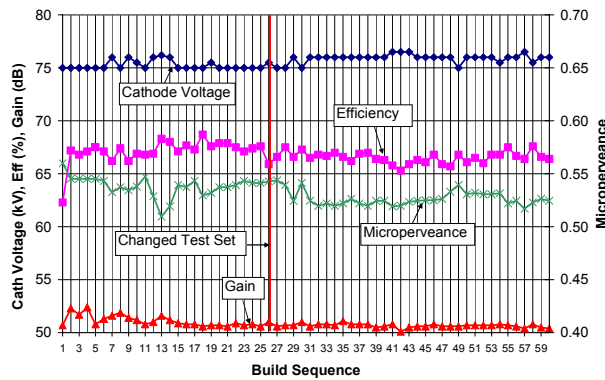

Figure 6: Summary of Performance in Build Sequence

At the time the 30th unit was being shipped, LANL approached CPI regarding delivery of additional units within contract period. A Critical Path Analysis (see Figure 7) was performed to analyze the production capability. Each process from our supplier's capabilities through packaging and shipment was evaluated. Equipment and personnel limitations were reviewed.

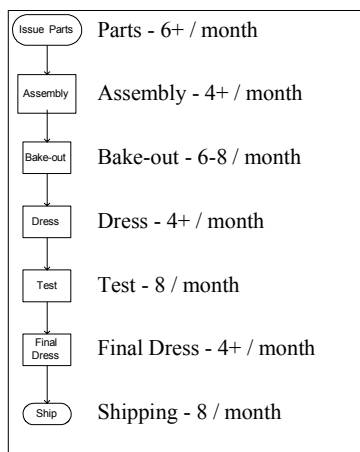

Figure 7: Critical Path Analysis

Fortunately equipment resources, especially the test stand were available and we determined 4 units/month achievable with a modest investment in fixtures. Based on this analysis and delivery commitment, CPI was awarded additional units. The actual delivery by month along with the original schedule for 65 units and updated schedule for the remaining contract are presented in Figure 8.

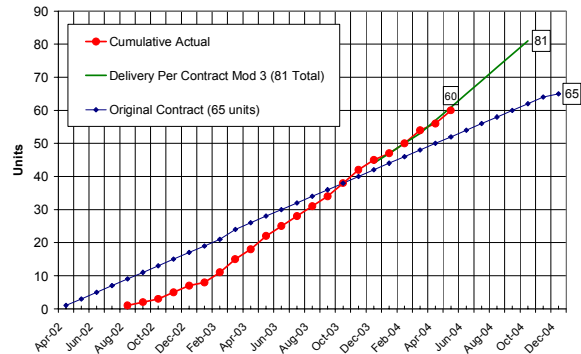

Figure 8: Delivery Schedule

CONCLUSION

The measured results instill high confidence in our simulation codes. The tube also demonstrates a high degree of stability under various operating conditions. Although the prototype 550-kW klystron did not meet the efficiency specification, all aspects of the specification have been met on all subsequent tubes.

ACKNOWLEDGEMENT

The authors would like to thank their co-workers at CPI for their contributions throughout the development of these products. They would also like to thank the CPI management team for their support. Finally many thanks go to the technical leaders and their colleagues at Los Alamos National Lab, in particular Dan Rees and Paul Tallerico.

REFERENCES

1. <http://www.sns.org>.
2. S. Lenci and E. Eisen, "Development and Production of An 805-MHz, 550 kW Pulsed Klystron For The Spallation Neutron Source," 6th Workshop on High Energy Density and High Power RF, AIP Proceedings, Volume 691(2003), pp 312-322.
3. S. Lenci, E. Eisen, B Stockwell, "Development of An 805-MHz, 550 kW Pulsed Klystron For The Spallation Neutron Source," PAC'03, May 2003, p. 1122.