

UPGRADING THE LNLS CONTROL SYSTEM FROM A PROPRIETARY TO A COMMERCIAL COMMUNICATIONS ENVIRONMENT

J. G. R. S. Franco, R. M. Ernits, M. C. Fernandes, A. F. A. Gouveia, J. R. Piton, M. A. Raulik, F. D. S. Rodrigues, LNLS, Caixa Postal 6192, Campinas-SP 13084-971, Brazil

Abstract

The LNLS Control System was built on a proprietary technology, due to the mid-80's Brazilian government IT policy. This made interfacing to commercial systems difficult, limited the technology transfer to the private sector, required a staff with specific knowledge and reduced the possibility of new implementations on the system. Nowadays, the cost to move all of our hardware to a commercial one is out of our budget. This paper describes a proposal, the viability study and first results to move only the communication interfaces to a commercial environment, keeping most of our hardware unchanged and opening the way to gradually move the system to widely accepted standards, when and if necessary. This solution allows a smooth implementation without long periods of machine shutdown and keeps the possibility to operate the machine concurrently between old and new communication interfaces.

THE LNLS CONTROL SYSTEM

The LNLS Control System [1] was designed in the mid 80's over a proprietary technology, due to governmental policy for IT. The first approach to build the system was to buy mostly in the national market and import only the absolutely necessary. To keep pace with other synchrotron facilities then under construction, a VME-compatible system was selected. The LNLS initially chose the G64 as the front-end hardware. However, in the late 80's, the Brazilian local market was unable to supply the hardware necessary to build the 50-MeV Linac's Test Control System due to the strict LNLS technical requirements. The bureaucracy and overtax of importing IT products kept the VME and G64 out of the LNLS budget. At that time, the closest, less expensive and reliable option was to make a proprietary hardware system.

The system currently used in the LNLS is based on an 8-bit microprocessor, running at up to 16 MHz and addressing up to 2 Mbytes of hardware-paged RAM and/or EPROM. The communication is multi-point, RS485-like with up to 14 nodes, galvanically isolated, from 2 to 8 Mbps and managed by an autonomous microprocessor or microcontroller. To minimize the bus contention, all data transfers between the main microprocessor and the serial board are made in 8 Kbytes of dual-port memory. The present system has 15 networks, 80 nodes and nearly 400 equipment interface boards. The general manager is a PC running a commercial visual operating system and a proprietary visual Pascal Control Program. The monitoring and alarm system is managed by a second personal computer, with

no privilege to send commands to the machine and only listening to the communication. The interface in those PCs is a proprietary ISA card. As the new PC generations no longer offer this bus, it is crucial to design an upgrade of the LNLS control system, like other facilities. [2]

THE UPGRADE PROPOSALS

By 2002 the LNLS Control Group started a series of viability studies to find a solution for the main challenge of the Control System: upgrading its primary interface, an ISA card, used only between PCs and the control networks. In this way, two approaches were defined – an USB card and a PCI card. A third suggestion was noted (Ethernet), but due to the complexity of this design the Control Group decided to postpone this project for a later universal solution involving all hardware and software currently used by the control system. The USB card was the first choice due to the hardware design simplicity and started to run in mid 2003. The PCI card project remained as an alternative. The viability study to integrate the USB card in the LNLS Control System demonstrated that it is a true option, but the maximum performance will be reached only with new basic software procedures, modifying the data exchange protocol between the main PC and the networks. The Control Group was then informed about a respectable number of hardware developers using new generation low-cost microcontrollers with integrated Ethernet Mac Controller. Looking for alternative suppliers of this kind of microcontrollers, we found some robust manufactures, showing that this alternative could be closer than initially supposed. At the end of 2003 we decided to try the Ethernet card option, changing the initial scope to another approach. That regards not only the issue of the hardware interface, but it leads to a new proposal: to upgrade the whole LNLS Control System. A commercial communications environment would be adopted and the PC software adapted with algorithms to share networks between our existing system and a new one on Ethernet, carrying smooth changes and without long periods of machine shutdown (Fig. 1).

THE ETHERNET ALTERNATIVE

As described above, all nodes of the LNLS Control System have two processors. One works as the node manager and the other as the communication manager. The microcontrollers with built-in Ethernet Mac controller and high-speed clock are a good way to combine the two processors in only one. In the LNLS Control System specific case, the chance to keep unchanged the equipment interfaces is very attractive.

The interfaces are reliable and have very low maintenance. In addition, it is considerable that the communication system can be upgraded without large high level software modification, opening the possibility to insert commercial equipments. To study this issue, the LNLS Control Group started two specific jobs: 1) the new hardware design with performance/stability tests and 2) the implementation of new high level algorithms to support a different protocol and shared networks. The most compatible hardware found for LNLS is an 8-bit microcontroller with multi-bus configuration, 10/100 Mbps Ethernet Mac, running at 50 MHz, providing a free C compiler and a free Stack TCP/IP library. This microcontroller can run the LNLS Control System low-level software with little adaptation and no change in the interface hardware. In the beginning of 2004, a prototype was running well enough to start the fundamental tests: data block transfers, TCP/IP socket stability, local function generation and auxiliary RS232 communication diagnosis. Besides the tests above, the LNLS Accelerator Physics Group and Operation Task Force listed a row of specific tests to improve the machine diagnosis, if they are implemented. These tests are online ramp checking, magnetic cycling checking and fast low-level data register.

second version, under test since then, uses binary transfers, with good results even without additional integrity control.

Data Transfers and TCP/IP Socket Stability

With the test software, it is possible to simulate the transfer and storage of a ramp profile data of the LNLS ring power supplies. This procedure was tested a number of times over 10 thousand loops of 2048 bytes transfers, without errors. It shows a good short-term stability of the TCP/IP socket and is about 20 times faster (approximately 2 against 40 seconds) than our present system. This performance is reached in a special configuration, due to the complexity to simulate the real topology of the LNLS control network. A decrease in this performance is expected for the final design. TCP/IP long-term stability was tested over 72 hours without errors at 10 Mbps. When working at 100 Mbps, the test crashed after 4 hours. The crash was detected in a PC environment and some more effort on it is needed.

Local Function Generation

The time to generate a floating-point function with 4096 words (2 bytes) is about 20 seconds. A better result was expected, but in the LNLS Control System this kind of operation applies only to magnetic cycling and the time constrain, imposed only by the coils inductance and power supplies, is bigger than 20 seconds. Thus, the Ethernet proposal is still valid. Another way to implement this operation with an improved method is to generate the floating-point calculation in the PC environment and transfer the calculated data to the microcontroller, like in the ramp generation. In this case the better characteristics of PC and the Ethernet would be used. The simulation of the operation above demonstrates that the full calculation, data transfer and magnetic cycling could happen in approximately 12 seconds.

Auxiliary RS232 Communication

The microcontroller under test has implemented two RS232 serial lines. One of them to be used as a console manager and the operational system allows implementing new console commands. It is possible to create specific commands to monitor and manage the customized operations for the LNLS Control System. The second serial line could be used to convert the RS232 protocol to the TCP/IP protocol for equipments with no Ethernet interfaces.

Online Ramp Checking

The aim of this test and (if possible) a future implementation is to verify the set point adjusted over an equipment and compare it to the current value. The software implemented on the target microcontroller, after each DA adjusts, executes an AD conversion and stores the result on a data block. When the ramp finishes, this data block is sent to the PC to detect possible errors. Another form of online checking is the microcontroller detecting possible values out of a prefixed window. If it

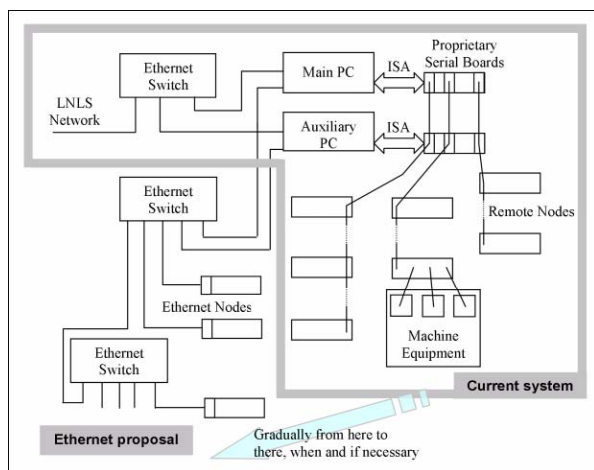

Figure 1: The current LNLS Control System Block Diagram and the Ethernet Proposal Upgrade.

THE VIABILITY STUDY

As a basic test prototype, the LNLS Control Group has built a single node with one Ethernet CPU, the target of the study, one AD/DA card used in most of the LNLS power supplies and one AD multiplex used to monitor different signals in the accelerators. A program written in C connects to a PC manager running a visual Pascal test program through a TCP/IP connection. The first version used literal characters to send and receive messages over Ethernet TCP/IP socket, to make easier the visualization of messages in network analyzers and obtain a mechanism to check the messages integrity, using special control characters. The aim of this process was to understand more of the low-level TCP/IP socket. The

happens, the microcontroller stops the ramp generation and replies to the PC with an error message. The first test is already implemented now. The time spent to generate the ramp with online monitoring is 600 ms (against 400 ms without it). As the current procedures to generate the ramp are longer than these time intervals, it is possible to confirm that this functionality could be implemented and the microcontroller performance for the ramp generation will not be compromised. As the best way to perform a magnetic cycling using this proposal is similar to a ramp generation, the same online checking could be implemented. The second procedure based on window values will be tested soon.

Fast Low-level Data Register

The fast low-level data register is important to detect instabilities directly in the equipment under control. Normally, in the LNLS Control System, unbuffered collected data is sent to be analyzed in the higher level. This transfer limits the sample rate for the time necessary to scan all the nodes in each network, because at this moment, except for the diagnostics nodes, the others do not have locally stored data. A simple procedure to convert the analog feedback signal of the equipment under control with the Ethernet prototype spends 28 microseconds to convert and stores 2 bytes, in a single task configuration. It will be necessary to implement a low-level concurrent multi-task algorithm to support the TCP/IP communication and data acquisition. This will allow estimating the sample rate expected for the LNLS Control System. By now, the figures show that even if the multitasking decreases the measured sample rate by 2, it will be difficult to transfer the full data collected to the higher level, due to the transmission time. Thus it will be necessary to provide a high-level priority algorithm to select the parameters under fast observation, deep low-level RAM memory and a smart low-level program to detect instabilities or inconsistencies.

THE HIGH-LEVEL SOFTWARE

The high-level primary interface software is implemented in a DDE client-server model, the networks being accessed only through a server to keep the data consistency. The access is done through ISA input and output procedures. These characteristics facilitate the implementation of a new algorithm to share the current network and the new one. By rewriting the ISA input and output procedures, it is possible to filter the messages and route them to the legacy networks or to Ethernet networks. This filter is based on information from the control system database. Only the server should be recompiled, keeping the client programs unchanged. Some tests are under progress in the Control Group with commercial Ethernet equipment to be installed soon in the LNLS Storage Ring. The LNLS Ethernet card prototype is emulating a power supply control. In this test we are dealing with an Ethernet and a legacy LNLS control network with 3 nodes. The results already show the

viability of the proposal, without any loss of performance in the test environment.

THE COST OF UPGRADING

A new commercial high performance CPU/Ethernet board with PC/104 interface was considered, but the cost of such hardware would be high, about US\$ 44 K (80 nodes at US\$ 500 plus US\$ 50 for the PC/104 interface). Its application on specific nodes (where very high performance is strictly necessary) is possible with the new high-level Ethernet server software. The budget necessary to move the present system to one based on the tested prototype is around US\$ 20 K (80 nodes at US\$ 250). The LNLS Control Group has a design of another prototype, based on the same microcontroller, but with only the necessary accessories and memory. With this card the budget necessary is about US\$ 12 K (80 nodes at US\$ 150).

CONCLUSION

The Ethernet communication standard is feasible in the LNLS Control System with no major changes. The experience showed that the performance of the chosen microcontroller is good enough to replace the current CPUs and Serial Controllers, with careful new implementations. Another one with optimized float-point operations will be tested. The TCP/IP Stack source code is very important to develop particular performance tests. The remodeling of LNLS Control System for a totally commercial one, at this moment, sounds unnecessary. Now the LNLS Control Group is producing other six prototypes to test the Ethernet proposal in a slightly more complex system. If everything works fine, in the third quarter of this year the LNLS Control Group will replace six nodes with the new ones. Based on the results presented here, the world trend to move to Ethernet Industrial control systems, the continuously developed Ethernet and Internet equipment and the proposals of new Real-Time Ethernet Protocols [3, 4], the choice of Ethernet on any platform would be a good decision, opening the opportunity to share homemade and commercial systems, which could improve the technology transfer between the LNLS and the private sector.

REFERENCES

- [1] J. G. R. S. Franco et al., "LNLS Control System", ICALEPCS 1999, Trieste, October 1999.
- [2] J. Meyer et al., "Upgrading the ESRF Accelerator Control System After 10 Years of Operation", ICALEPCS 2003, Gyeongju, October 2003.
- [3] A. Augelli, PROFIBUS Day - Brescia, June 2003, http://www.inntec.it/profilab/download/ProfibusDay2003/Profibus_Day_Augelli.pdf
- [4] K. Bothamley and J. Rodgerson, "Emerging Ethernet Protocols", <http://www.manukau.ac.nz/departments/e/research/2002/kb.pdf>