

INJECTOR AND BUNCH COMPRESSOR FOR EUROPEAN XFEL

Yujong Kim*, K. Flöttmann, T. Limberg, and M. Dohlus, DESY, D-22603 Hamburg, Germany
 Dongchul Son and Y. Kim, The Center for High Energy Physics, Daegu 702-701, Republic of Korea

Abstract

In this paper, we describe optimization and design concepts of the XFEL injector and bunch compressors to reduce beam quality dilution due to the microbunching instability and coherent synchrotron radiation (CSR).

INTRODUCTION

Generally, SASE source properties strongly depend on electron beam parameters such as slice and projected normalized rms emittances, slice rms relative energy spread, and peak current. These parameters are mainly determined by the injector system and bunch compressors (BCs) in the FEL driving linac. Recently it was reported that electron and photon beam quality can be significantly diluted by the microbunching instability in the bunch compressors [1, 2]. The microbunching instability is induced by collective self-fields such as CSR, longitudinal space charge (LSC), and geometric short-range wakefields when electron beams have a modulation in current density profile and/or energy profile at the upstream of bunch compressors [1, 2]. It is well known that the microbunching instability can be smeared by Landau damping if slice emittance and/or slice energy spread is large enough [1, 2]. For the proper operation of SASE FEL facility, there is no enough margin in the slice emittance, while there is somewhat larger margin in the slice rms relative energy spread. To supply hard X-ray SASE sources, DESY has a plan to build the largest SASE FEL light source facility in the world, European XFEL [3]. Its main required parameters are summarized in Table 1. For the European XFEL, originally, we had a plan to use three BC stages with one normal chicane for the first BC (BC1) and two S-type chicanes for the 2nd and 3rd BCs (BC2 and BC3) as shown in Fig. 1(top). But recently, we found that two S-type chicanes invoke the strong microbunching instability [2, 4, 5]. Hence, we have changed the BC layout into one BC stage with a double chicane as shown in Fig. 1(bottom) [5, 6]. In this paper, we describe our design concepts of the injector and bunch compressors for the European XFEL project.

INJECTOR FOR XFEL PROJECT

Recently, by the help of a flat-top laser profile with about 21 ps (FWHM) length and about 7 ps rising and falling time, TTF2 gun (originally PITZ1 gun) could generate high quality electron beams with a projected normalized rms emittance of about $1.7 \mu\text{m}$ at the gun exit, which is well agreed our ASTRA simulation for the gun [7]. After

Table 1: Main parameters for XFEL project.

Parameter	Unit	Value
beam energy E	GeV	20
single bunch charge Q	nC	1
slice normalized rms emittance ϵ_{ns}	μm	1.4
slice rms relative energy spread $\sigma_{\delta s}$	10^{-4}	1.25
peak current I_{pk}	A	5
maximum bunch train length	μs	650
bunch train repetition rate	Hz	10
minimum bunch spacing in a train	μs	0.2
wavelength of SASE source	nm	0.08-6.4
saturation length of SASE source	m	95-170
total undulator length	m	140.3-250.1

considering two facts that slice normalized rms emittance should be smaller than $1.4 \mu\text{m}$ at the undulator entrance, and projected and slice emittances can be diluted at bunch compressors due to the microbunching instability and CSR, we determined that the XFEL injector should supply much higher quality electron beams with a smaller projected normalized rms emittance.

This required higher quality electron beams can be supplied by upgrading current operating TTF2 gun with following steps [7]: First, transverse laser profile will be improved to have a good homogeneous intensity and longitudinal laser profile will be improved to have a good uniform flat-top shape with a shorter rising and falling time. These improvements will help in reducing emittance growth at head and tail regions due to the nonlinear space charge force as shown in Fig. 2. Second, the maximum gradient at the cathode will be increased from current 42 MV/m to 60 MV/m which will also help in reducing space charge force effects. Third, we will align laser on the cathode and solenoid misalignments by the beam based alignment. Fourth, several fine optimizations will be done under 60 MV/m gradient: gun RF phase optimization to get the maximum energy gain, laser pulse length optimization to control longitudinal space charge force, laser spot-size optimization at the cathode to control transverse space charge force and thermal emittance, the main solenoid current optimization for the emittance compensation, bucking solenoid current optimization to reduce emittance growth by the non-zero magnetic field on the cathode [7, 8]. Fifth, we will re-compensate the second emittance growth due to space charge force in the drift space between gun and the booster linac by installing the first TESLA superconducting module (ACC1) at the so-called *Ferrario matching point* as shown in Fig. 2 [8]. Here, the first four cavities in ACC1

*E-Mail : Yujong.Kim@DESY.de, URL : <http://TESLA.DESY.de>

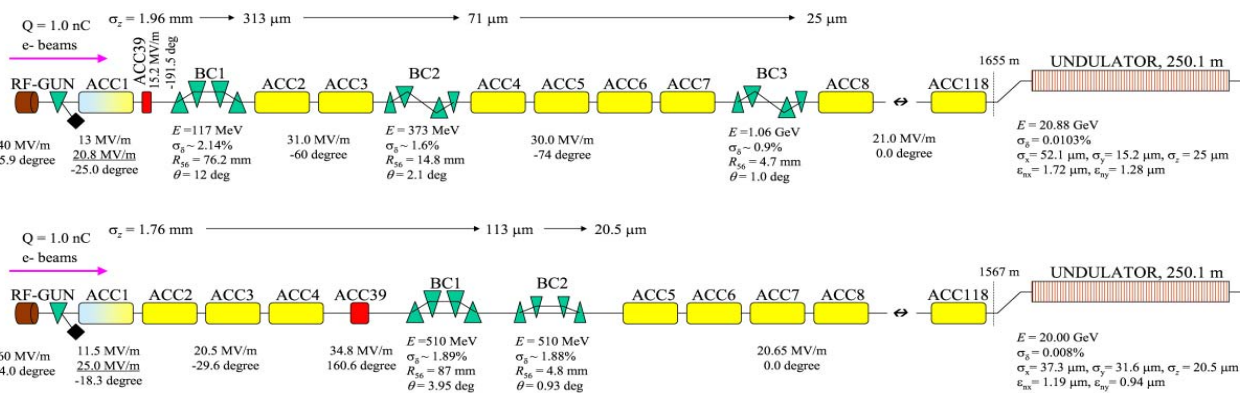

Figure 1: Old (top) and new (bottom) layout for XFEL project. Here all parameters are projected ones.

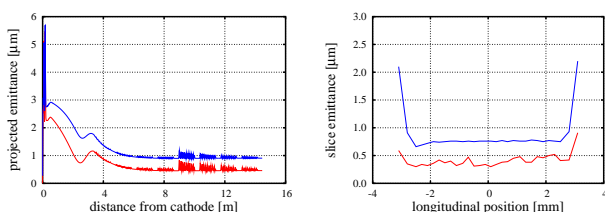

Figure 2: XFEL injector ASTRA simulation results: (left) projected normalized rms emittance up to the end of ACC1, and (right) slice normalized rms emittance at the end of ACC1. Here red (blue) line indicates emittance when rising/falling time is zero (1.5 ps), and thermal emittance is zero ($0.64 \mu\text{m}$).

have a lower gradient to satisfy the *Ferrario matching condition* and the last four cavities in ACC1 have a higher gradient to get a higher beam energy [8].

According to our ASTRA simulations for the XFEL injector, we may generate higher quality electron beams with a projected normalized rms emittance of around $0.9 \mu\text{m}$ by following above optimization steps. Its simulation results are shown in Fig. 2, and its detail simulation conditions are summarized in Table 2.

BC FOR XFEL PROJECT

Bunch compressor design concepts are well described in *one of two papers* in reference [2], which is related with the SCSS bunch compressor. The same concepts are basically used in designing our XFEL bunch compressors. Generally, S-type chicane is useful in compensating the projected emittance growth due to CSR because dispersion is reversed inside of the chicane [4]. But its overall CSR strength is much higher than that of the normal chicane with four dipoles because S-type chicane has two additional dipoles [4]. Specially, if current density profile and/or energy profile have a modulation before the S-type chicane, its CSR microbunching instability is stronger than

Table 2: S2E simulation results for XFEL project.

Parameter	Unit	Value
RF frequency of gun and TESLA module	GHz	1.3
gun cell number	cell	1.5
laser spotsize at cathode σ_r	mm	0.75
laser pulse length (FWHM)	ps	20
laser pulse rising and falling time	ps	1.5
normalized thermal emittance	μm	0.64
maximum longitudinal solenoid field	T	0.1988
maximum gradient at the cathode	MV/m	60
gun phase from zero crossing	deg	44
low / high accelerating gradient in ACC1	MV/m	11.5 / 25
ACC1 phase from on crest	deg	-18.3
projected emittance before BC1 / BC2	μm	0.90 / 1.02
slice emittance before BC1 / BC2	μm	0.76 / 0.76
bunch length before BC1 / BC2	mm	1.76 / 0.11
beam energy before BC1 / BC2	MeV	510 / 510
projected energy spread before BC1 / BC2	%	1.89 / 1.88
slice energy spread before BC1 / BC2	10^{-5}	0.85 / 4.8
projected emittance after BC2 / LINAC	μm	1.19 / 1.19
slice emittance after BC2 / LINAC	μm	0.76 / 0.76
bunch length after BC2 / LINAC	μm	20.5 / 20.5
beam energy after BC2 / LINAC	GeV	0.51 / 20.0
projected energy spread after BC2 / LINAC	%	1.8 / 0.008
slice energy spread after BC2 / LINAC	10^{-4}	5.56 / 0.06

that of the normal chicane [4, 5].

To avoid slice parameter dilution due to the microbunching instability in BCs, we have adopted followings in our new layout as shown in Fig. 1(bottom): First, to reduce overall CSR strength, we choose only two bunch compressors with the normal chicane instead of S-type chicane. Therefore the total number of dipoles for bunch compressors is reduced from 16 to 8 in our new layout. Second, to keep the slice rms relative energy spread at the entrance of BC2 large, we put BC2 at somewhat low energy region

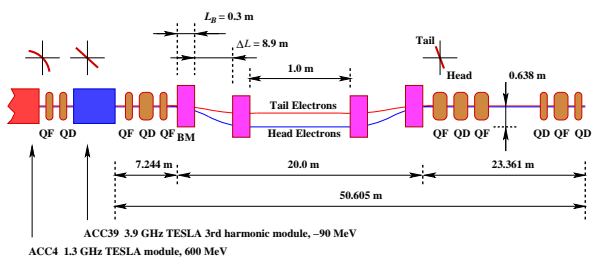

Figure 3: BC1 layout for XFEL project. BC2 chicane has the same layout.

without any acceleration between BC1 and BC2. In this case, BC1 and BC2 have almost same projected rms relative energy spread of around 1.89%. Third, during compression in BCs, slice energy spread generally becomes larger to conserve the normalized longitudinal emittance. Therefore slice rms relative energy spread before BC2 can be further increased up to 4.8×10^{-5} by compressing bunch length at BC1 strongly. Since the compression factor at BC1 is high, and there is no acceleration between BC1 and BC2, we put BC1 and BC2 at 510 MeV to avoid any beam dilution due to space charge force. To investigate space charge force effects in BCs, we used CSRtrack code which can consider space charge force as well as CSR in BCs [9]. From CSRtrack simulations, we confirmed that beam dilution due to space charge force is ignorable at 510 MeV.

To avoid projected emittance dilution due to CSR in BCs, we have adopted followings in our new layout as shown in Figs. 1(bottom) and 3: First, to reduce CSR, we should choose a smaller momentum compaction factor R_{56} of chicane. This is possible by choosing a somewhat larger projected rms relative energy spread σ_δ [2]. After considering the emittance growth due to chromatic effect, we choose $\sigma_\delta \simeq 1.89\%$ at our double chicane. Second, we choose short quadrupoles around BCs to reduce emittance growth due to chromatic effect. Third, for a required R_{56} , we can reduce dipole bending angle (hence, CSR) further by using a longer drift space ΔL between the first dipole and the second one as shown in Fig. 3 [2]. Fourth, generally, CSR is weaker at BC1, and CSR becomes stronger at BC2 as bunch length is compressed. Hence, we choose a higher compression factor at BC1 and a lower compression factor at BC2 to reduce overall CSR effects in our double chicane. Fifth, we reduce CSR further by installing a 3rd harmonic module (ACC39) before BC1 to compensate nonlinearities in the longitudinal phase space as shown in Fig. 3 [2]. In our new layout, ACC39 is moved from about 130 MeV to about 600 MeV region. Therefore beams are decelerated by about -90 MeV at ACC39 [2]. Sixth, the projected emittance dilution due to CSR can be reduced further by forcing the beam waist close to the last dipole where α -functions are zero, and β -functions are their minimum [2, 5].

We have performed Start-to-End (S2E) simulations with ASTRA and ELEGANT codes to estimate beam param-

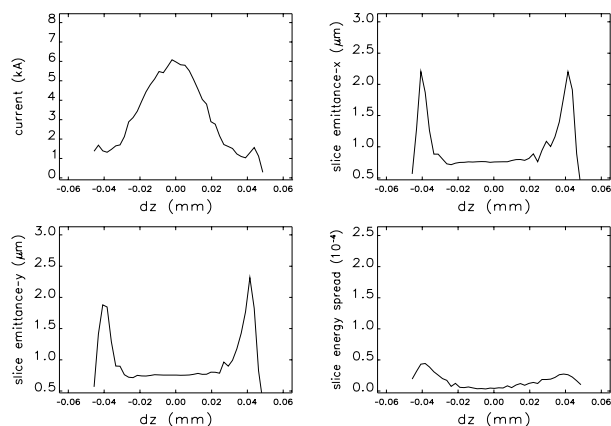

Figure 4: Slice parameters at the end of XFEL linac.

eters at the end of the European XFEL linac as shown in Fig. 1(bottom) and summarized in Table 2. Here emittance, energy spread, and bunch length are estimated in *normalized rms*, *rms relative*, and *rms*, respectively, and slice parameters before BC2 (after BC2) are estimated at ± 0.1 mm (± 0.02 mm) core region. In these simulations, we have included all important impedances such as space charge force in gun and ACC1, CSR in BCs, and geometric short-range wakefields in all modules [5]. According to our S2E simulations, obtained all slice parameters at the end of the XFEL linac are much better than our requirements as summarized in Table 2 and shown in Fig. 4.

SUMMARY

By putting BC2 at a lower energy region, by removing accelerating module between BC1 and BC2, and by choosing high compression factor at BC1, we can increase slice energy spread before BC2 up to 4.8×10^{-5} which is good enough in smearing the strongest microbunching instability with 2.0 ps period [1, 2]. Since CSR effects is ignorable in our new layout, all projected and slice parameters are much better than our requirements for the XFEL project. Now, we are under designing another layout with two BC stages with two bunch compressors. After investigating jitter tolerance for a double chicane and two BC stages cases, we will determine our final linac layout [1].

REFERENCES

- [1] Yujong Kim *et al.*, in these proceedings.
- [2] Yujong Kim *et al.*, NIMA, to be published in July 2004.
- [3] <http://XFEL.DESY.de>
- [4] http://www.desy.de/~yjkim/TESLA_S2E_2003_10.pdf
- [5] http://www.desy.de/~yjkim/TESLA_S2E_2003_14.pdf
- [6] http://www.desy.de/~yjkim/TESLA_S2E_2004_22.pdf
- [7] M. Krasilnikov *et al.*, in these proceedings.
- [8] M. Ferrario *et al.*, DESY report No. TESLA-FEL 2001-03.
- [9] M. Dohlus, DESY report No. TESLA-FEL 2003-05.