

# STATUS OF THE VACUUM SYSTEM FOR THE IPHI PROJECT ( High Intensity Proton Injector )

N. Rouvière\*, F. Dubois, R. Leplat, L. Vatrinet  
 CNRS / IN2P3 / IPN-Orsay, 15 rue G. Clémenceau - 91406 ORSAY - France  
 R. Gobin, F. Harrault, P.A. Leroy  
 CEA-Saclay 91191 Gif-sur-Yvette Cedex - France

## Abstract

A High Intensity Proton Injector (IPHI) prototype is being built at CEA-Saclay. It is foreseen to provide a 1 MW proton beam with a reliability of 95 %. This paper describes the different parts of the vacuum system and the status of the related studies. The High Energy Beam Transport line (HEBT) is dedicated to the diagnostics. Specially, one of them is based on fluorescence issued from beam-residual gas interaction. To avoid any parasitic reflected light, a "black layer" is sprayed on the vessel wall of which desorption is studied.

## 1. INTRODUCTION

The IPHI project is the first step of an important R&D program jointly supported by the two French CEA and CNRS research agencies [1]. Such a light ion injector is the first part of many MW accelerators devoted to the transmutation of nuclear waste or the new generation of exotic ion facilities [2].

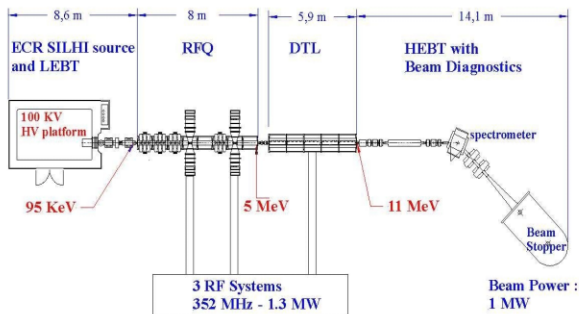

Fig.1 - The IPHI project layout.

This device will supply a 100 mA-10MeV CW beam. It is set up in several parts (Fig.1) :

In a first phase :

- an Electron Cyclotron Resonance (ECR) source : SILHI (High Intensity Light Ions Source), which is now running and produces a 100 mA CW protons beam at 95 keV routinely,
- a Low Energy Beam Transport line (LEBT) to analyse the beam extracted from the source,
- a Radio Frequency Quadrupole (RFQ) to accelerate ions up to 5 MeV,

- and a High Energy Beam Transport Line (HEBT) to characterise the high intensity protons beam.

In a second phase, a Drift Tube Linac (DTL) will be added to carry out the energy up to 10 MeV.

The demand for the vacuum of the IPHI is an average pressure of  $P_1 = 2.10^{-5}$  Pa. The choice of the pumps ( design and maintenance) must fulfil the requirement of an overall reliability better than 95%.

## 2. LOW ENERGY BEAM TRANSPORT LINE

The 4 m long LEBT line provides a 10 kW beam (100 mA - 100 keV) and allows to analyse the beam characteristics by means of different diagnostic elements, such as : two CCD cameras, 2 toroids (DCCT, ACCT), Faraday cup, emittance measurement unit (EMU), etc.

The pumping system is set up by two 1000 l/s turbo molecular pumps with associated dry pumping. These pumps maintain the  $1.10^{-3}$  Pa pressure necessary for the space charge compensation of the proton beam .

A 1000 l/s cryogenic pump, located just at the RFQ entrance, decreases the pressure down to  $P_2 = 6,7. 10^{-4}$  Pa and makes as a barrier to prevent contamination by hydrocarbons towards the RFQ.

Presently, the LEBT is close to be completed , the vessel and the cryogenic pump remain to be installed.

## 3. RADIO FREQUENCY QUADRUPOLE

The 352 MHz RFQ purpose is to catch the beam extracted from the ion source and to accelerate it up to 5 MeV with a high efficiency (90%) and a good optical quality (emittance) to minimise losses at high energy.

The RFQ is composed of eight sections (1 m long and 0.3 m diameter each). Two sections (S4 and S7) are equipped with two wave guides for the RF power and the sections are devoted to the RF tuning devices and the pumping system. Each section is equipped with 12 pumping ports (6 by side). To avoid a large number of valves and pumps, we plan to connect on each section the pumping port together by manifolds (Fig.2)

To define the pumping speed of the pumping system, we must know the gas load. It comes from the LEBT, the

\*rouviere@ipno.in2p3.fr

beam losses in the RFQ, the RFQ copper wall desorption and from the HEBT.

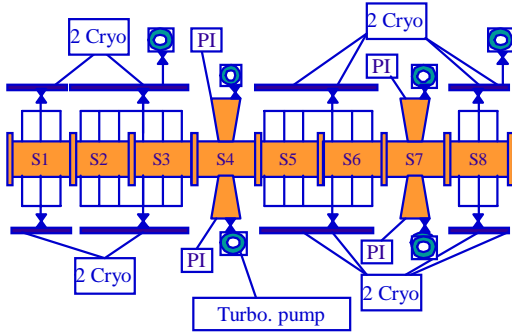

Fig.2 - Vacuum systems of the RFQ..

- from the high pressure in the ion source and in the LEBT (see above) through a conductance of 12 mm diameter just at the entrance of the RFQ.

$$Q = C(P2-P1) = 8.6 \cdot 10^{-6} \text{ Pa.m}^3 \cdot \text{s}^{-1}$$

- from the beam losses in the RFQ, the Fig.3 shows the distribution of these losses. [3]

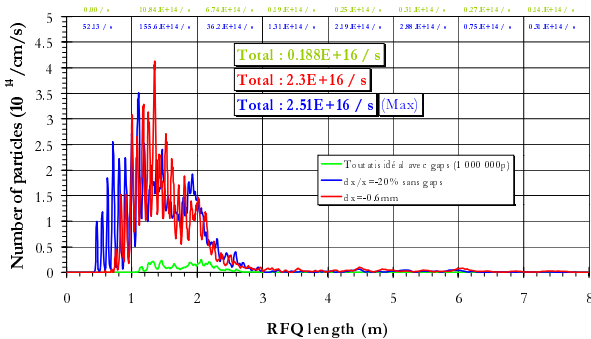

Fig.3 - The beam losses along the RFQ.

The loss amount is estimated to 4 mA ( $2.5 \cdot 10^{16}$  p/s). To determine the rate desorption of the copper wall RFQ due to the losses, a 100 keV CW proton beam was used to irradiate a OFHC copper sample inside a vacuum vessel of the LEBT. As a desorption bench, the vacuum vessel is divided in two parts (high and low pressure) by a conductance (8 mm diameter). The beam incidence angle was  $60^\circ$  versus the perpendicular of the sample. The impact area beam/sample was  $1 \text{ cm}^2$ . The intensity beam was adjusted from 1 mA up to 10 mA. The measurements were made successively without bake out and with a bake out at  $120^\circ\text{C}$  during 24h. The results are summarised on Fig.4

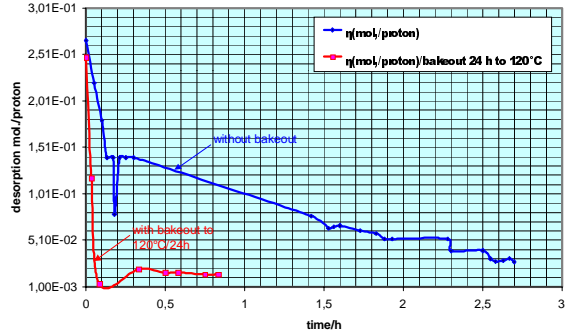

Fig.4 - Cu desorption due to proton beam impact.

The first results of this study show that a proton beam cleans completely the area in few minutes. A 1 mA proton beam ( $6,25 \cdot 10^{15}$  p/s/cm<sup>2</sup>) produces  $2.6 \cdot 10^{-2}$  mol/ proton or  $1.6 \cdot 10^{14}$  mol/s/cm<sup>2</sup> corresponding to the surface coverage. This yield is optimistic compared to other measurements [4], probably because the release is saturated by the proton concentration.

The second conclusion is : after the surface ablation, the flux is limited that due to inner stimulated diffusion and a further increase of the proton intensity (after 1.5 hour) does not change the desorption rate per proton.

The third conclusion is : a weak bake-out is efficient to decrease the desorption rate by, at least, a factor of 10. The residual components are then : H<sub>2</sub> : 74.9%, H<sub>2</sub>O : 10.5%, CO : 9.6%, CO<sub>2</sub> : 5.1%. The water line is connected to the long range of 100 keV protons in copper ( $0.55 \cdot 10^{-3}$  mm).

To summing up, the action of the incidence must be studied soon to get a better estimate of the desorption in accordance with beam dynamics studies.

- from the RFQ copper wall, with an outgassing rate of  $4 \cdot 10^{-7} \text{ Pa.m.s}^{-1}$  [5] and a total area of the 8 sections of  $9 \text{ m}^2$ , the total gas load is :  $3.6 \cdot 10^{-6} \text{ Pa.m}^3 \cdot \text{s}^{-1}$ .
- From the HEBT, the gas load is mainly due to the stainless steel of the chamber walls. In addition, a part of the wall is covered with a “black layer”, which desorption is described in the next paragraph.

#### 4. HIGH ENERGY BEAM TRANSPORT (HEBT)

The 10.5 m long HEBT equipped with diagnostics allows to define the beam extracted from the RFQ. The different diagnostic systems are : 4 toroids (ACCT, DCCT), 3 pick-up electrodes, 3 beam positions monitors (BPM), 2 wire scanners, 3 profilers. And more, a diagnostic based on interaction of residual gas or additional gas (N<sub>2</sub> or Ar) and accelerated particles [6]. A turbo molecular pump will be added to absorb the gas

load. This interaction based on the fluorescence effect needs to prevent any reflected light on the vacuum vessel wall, then a “black layer” is sprayed on it, which desorption was studied.

- The outgassing rate measurements were made in a standardised bench (150 CF diameter, fig.5). The bench is made of stainless steel (316LN). A calibrated conductance C (5,8 10<sup>-3</sup> m<sup>3</sup>. s<sup>-1</sup>) separates the high and low pressure sides. The “black layer” (NEXTEL-Velvet-Coating 811-21) is sprayed on 10 samples (2 faces – 10 cmx10 cm). The brilliance is : RS inferior to 2 under an angle 85° (DIN 67630 : ISO 2813).

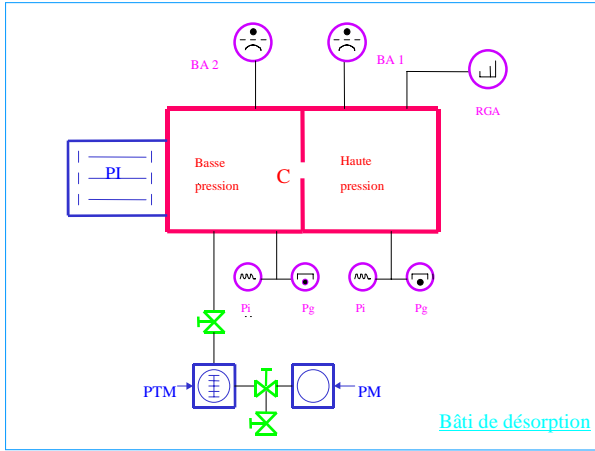

Fig. 5 – Scheme of the desorption bench.

The gas flows Q<sub>1</sub> and Q<sub>2</sub> are measured without and with samples. The sample desorption rate is then (Fig. 6) :  
 $\alpha = (Q_2 - Q_1) / S$  (S : area samples).

time (hours)	$\alpha$ : "black layer" desorption rate (Pa .m.s <sup>-1</sup> )
$\alpha_{1 H}$	6,40 10 <sup>-4</sup>
$\alpha_{10 H}$	2,30 10 <sup>-5</sup>
$\alpha_{48 H}$	2,00 10 <sup>-6</sup>
$\alpha_{100 H}$	9,60 10 <sup>-7</sup>

Fig. 6 - “black layer” desorption rate

The gas analysis is given on fig. 7 [6].

H <sub>2</sub>	28.3%
CH <sub>4</sub>	25.7%
H <sub>2</sub> O	17.6%
CO	9.2%
CO <sub>2</sub>	7.8%
C <sub>n</sub> H <sub>n</sub>	11.4%

Fig. 7 – Components of the “black layer” outgassing

Conclusion : the “black layer” (NEXTEL-Velvet-Coating 811-21) is a convenient coating. The rate desorption after 100 hours is a factor 10 higher than that of a no baked-out stainless steel. However, the gas analysis exhibits hydrocarbon lines ( 11,4 % ).

## 5. CONCLUSION

- The action of the incidence of the proton beam must be studied soon to get a better estimate of the total gas release inside the RFQ in accordance with beam dynamics studies.
- The chosen “black layer” for fluorescence diagnostics has a desorption rate compatible with the vacuum requirements but with hydrocarbon lines, we prospect for a better product.

## 6. ACKNOWLEDGEMENT

We would like to thank P.Y. Beauvais, R. Gobin and all other colleagues from CEA for their fruitful collaboration in this joint project. We would like to thank J. Arianer for helpful discussions.

## 7. REFERENCES

- [1] - P.Y. Beauvais et al., "Status report on the Saclay I.P.H.I. project", Proc. of the 7<sup>th</sup> EPAC , Vienne (2000) 283.
- [2] - J.M. Lagniel, "High power proton linac for a multi-user facility", Proceedings of the 7<sup>th</sup> EPAC, Vienne (2000) 945.
- [3] - R. Ferdinand, P. Mattei. La dynamique du RFQ du projet IPHI –DSM/DAPNIA/SEA.98/71.
- [4] - O. Gröbner. CERN Report 99-05.
- [5] - G. Rommel. Notions de base en technique du vide – SFV- 1995.
- [6] - P. Ausset, D. Gardes, B.Pottin, A.C. Mueller Optical transverse beam profile measurements for high power proton beam.– This conference.
- [7] - C. Biguenet.– LE VIDE N°159-160