

# SYSTEM DESIGN OF ACCELERATOR SAFETY INTERLOCK FOR THE XFEL/SPRING-8

M. Kago, T. Matsushita, N. Nariyama, C. Saji, R. Tanaka, A. Yamashita,  
 JASRI, XFEL Joint Project/SPring-8, Hyogo, Japan

Y. Asano, T. Fukui, T. Itoga, RIKEN, XFEL Joint Project/SPring-8, Hyogo, Japan

## Abstract

The accelerator safety interlock system (ASIS) for XFEL/SPring-8 protects personnel from radiation hazards. The ASIS consists of three independent systems: central, emergency, and beam-route interlocks. If the ASIS detects an unsafe status, it turns off the permission signal for accelerator operation, thereby stopping the electron beams. The delay time for the permission signal propagation must be less than 16.6 ms. Furthermore, reliability and stability of the personnel protection system are indispensable. Therefore, we have used programmable logic controllers for stability and developed optical modules for fast signal transmission. In this paper, we describe the system design of the ASIS.

## INTRODUCTION

The X-ray free electron laser (XFEL) facility is located at the SPring-8 site. The XFEL accelerator consists of an 8 GeV linear accelerator and undulators. The XFEL electron beam is designed to have a maximum repetition frequency of 60 Hz, and it is switched to two beam lines (BL1 and BL3) using a bending magnet. In the final plan, the electron beam is switched among five BLs.

Radiation safety is very important. Therefore, the accelerator safety interlock system (ASIS) was carefully designed to protect personnel from radiation hazards [1]. The most important feature of ASIS is to allow accelerator operation only when personnel safety in the machine tunnel is guaranteed. The basic functioning of the ASIS is based on the ASIS of SPring-8 [2].

## HARDWARE

In order to achieve fail-safe and highly reliable system, the hardware components of ASIS should be simple. Therefore, the ASIS design was divided into three separate systems, which independently perform the three main functions of ASIS. These systems are a central interlock system (CIS), an emergency interlock system

(EIS), and a beam-route interlock system (BIS). They are implemented on programmable logic controllers (PLCs), and isolated from other systems and networks. The important equipment of the ASIS are as follows:

- System key: It is located in the control room; it switches the operation status of the accelerator.
- Door switches: These are installed on doors that access to the machine tunnel. When a door is closed, its door switch is turned on.
- Personal keys: These are placed on a personal key box (PK-BOX). A person who enters the machine tunnel should take a key from the PK-BOX located near the door and must carry it while in the tunnel.
- Emergency stop buttons: These are located in the machine tunnel at intervals of about 50 m.
- Search buttons: When the accelerator operation begins, the machine tunnel is searched to ensure that no one remains there. When the search team checks a portion of the tunnel, a search button is pushed to indicate that the area was searched.
- Status indicators: These are installed near the doors, and indicate the operation state.
- Bending magnets: The ASIS monitors key bending magnets to check the electron beam route.

Figure 1 shows location of the equipment.

## PERMISSION

ASIS ensures the safety of personnel by controlling the permission of operation given to the electron gun (GUN) and 73 accelerator radio frequencies (RFs). Their high voltage is turned off when the operation permission is denied. In addition, if electrons are not to be injected into the dump core, the ASIS must stop the electron beam within 16.6 ms in order to avoid the injection of the next beam bunch. We adopted the GUN deflector as the safety equipment to quickly stop the beam and a new optical module for faster transmission of the permission.

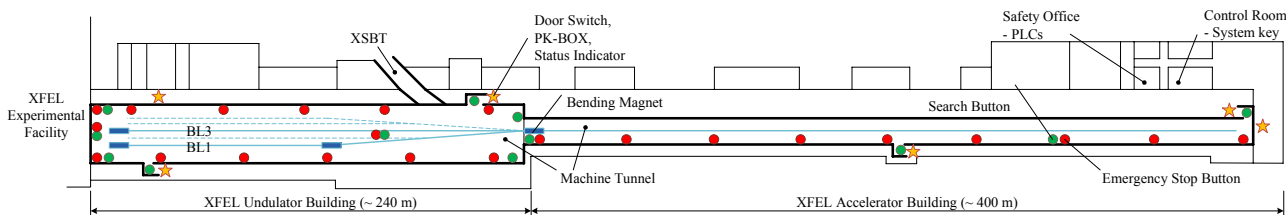

Figure 1: Location of the equipment.

## Optical Module

We have developed optical modules that respond quickly and have a circuit to merge permission signals. This module is daisy-chained via fiber optic cables and transmits the permission signal to the GUN and RFs. Permission signals are sent and received via two fiber optic cables. One of the cables is used to send and receive a static signal for fast transmission. The other is used to transmit a pulse signal (1 kHz) to a watchdog timer for high reliability. Both the signals are permission signals. If either of the signals trips, the permission signal is turned off. The trip state is maintained until a reset signal is transmitted. Only when the permissions of all three systems are on, the GUN and RFs are permitted to operate. Figure 2 shows how the permission signals are transmitted. There are three types of optical modules:

- Type A serves as the interface with the PLC.
- Type B inputs/outputs the permission signal from the external instruments.
- Type C outputs the permission signal to the GUN and RFs.

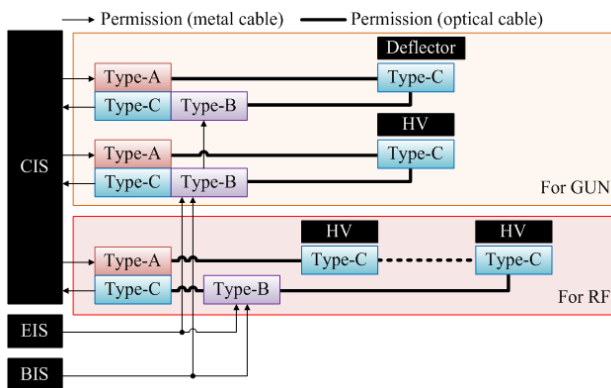

Figure 2: Transmission of permission signals.

## SYSTEM CONFIGURATION

Each system monitors the safety condition for which it is responsible; the systems communicate only necessary signals to each other over hardwired connections. If any system detects an unsafe status, the permission signal from the system must be turned off. The status of the systems is collected and stored in a database server through a data collection module.

### Central Interlock System (CIS)

This system is the main component of the ASIS and ensures machine tunnel security by monitoring the status of safety equipment, such as, door switches and search buttons. Signals from the equipment are inputted to a PLC through remote input/output (RIO) devices. The system configuration is shown in Figure 3.

The CIS switches the operation status of the accelerator by the use of the system key and the status of monitored equipment. The operation status has three states: “STOP,” “READY,” and “RUN.”

In the “STOP” state, accelerator operation is not permitted and the personnel can access the machine tunnel.

In the “READY” state, the machine tunnel is searched before beginning accelerator operation. Accelerator operation is not permitted and access to the machine tunnel is denied to all personnel other than the search team.

The operation status changes to the “RUN” state when all the safety conditions given below are satisfied and the system key is in the “RUN” position.

- All doors are closed.
- All personal keys have been returned to the PK-BOX.
- All emergency stop buttons are inactive (not pushed). This status is monitored by the EIS.
- The tunnel search is complete (all search buttons have been pushed).

In the “RUN” state, no one can access the machine tunnel. If an anomaly occurs in the safety condition, the operation status is tripped to the “READY” state, and the machine tunnel must be searched again.

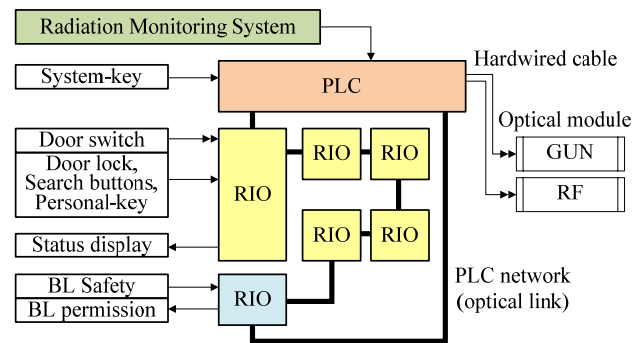

Figure 3: CIS configuration.

### Emergency Interlock System (EIS)

The EIS only monitors the status of the emergency stop buttons because these are important safety equipment. This system works even if the operation status is “STOP” or “READY.” Signals from the buttons are inputted to the EIS through RIO. If the buttons are pushed, the EIS turns off the permission to the GUN and RFs through the CIS. In order to enhance reliability, optical modules were installed as independent systems for similar function. Optical modules also manage permissions of the GUN and RFs (Figure 4).

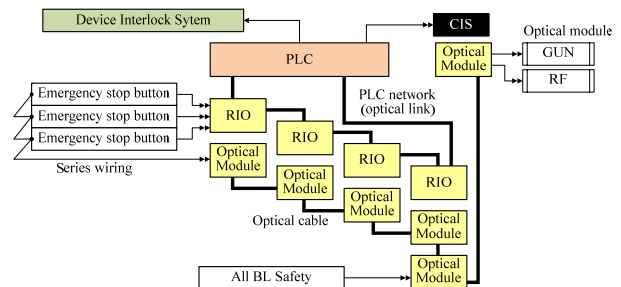

Figure 4: EIS configuration.

### Beam-route Interlock System (BIS)

The BIS monitors current values of the bending magnets at beam switching points because this ensures that the electrons are injected into the dump core. When a particular value is out of the specified range, this system stops the GUN. The system monitors the switching magnet, kickback magnet of BL1, and beam dump magnet of each BL. The BIS consists of a main PLC (M-PLC), an energy PLC (E-PLC), and local PLCs (L-PLCs). All PLCs are linked by a PLC network (Figure 5).

The E-PLC is located in the safety office room and accepts the energy data of accelerator operation through a graphic panel. The E-PLC calculates the correct current values of each magnet using this energy data and sends these values to the L-PLCs. Each L-PLC is installed in the rack of each magnet's power supply. An analog signal proportional to the actual current of the magnet is inputted, and the L-PLC compares the correct current with the input current. If the difference between both the currents is less than  $\pm 1\%$ , then the PLC outputs a normal signal to the M-PLC. The output signal is converted from an electrical signal to an optical signal. The M-PLC is located in the safety office room and checks the electron beam route based on the normal signals received from each L-PLC. If the beam route is unsafe, it does not permit accelerator operation and stops the electron beam.

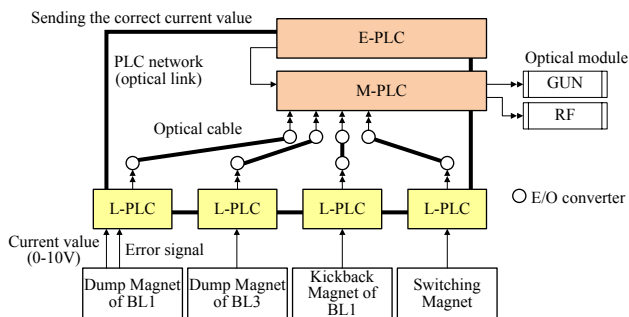

Figure 5: BIS configuration.

### Data Collection Module

The information obtained from the ASIS is stored in a database server through a data collection module. The information stored on the database is useful for easy maintenance and troubleshooting of ASIS. The module is connected via FL-net cable. FL-net interconnects the module and the VMEbus system, and the interconnection thus prevents direct access to the safety system from the accelerator control. The module consists of a PLC and is installed in the safety office room. Information from the CIS, EIS, and BIS is collected via an independent FL-net.

### RESPONSE TIME

The BIS requires a short processing time because beam injection must be stopped within 16.6 ms when it detects

an electron beam route mismatch. The permission from the BIS is transmitted to the GUN through many devices: the optical module, L-PLC, M-PLC, and E/O converter. We have measured the response time of each device in order to calculate the total response time. However, the actual response time of a PLC could not be measured in the present study because the PLC software is still under development. In order to estimate the response time of a PLC, we have measured the worst response time using the shortest program. From the results of 30000 measurements, 0.586 ms was found to be the worst response time. Table 1 lists the response times of the devices. The L-PLC and M-PLC softwares were designed so as to complete less than 440 steps because they only perform simple processing, such as data comparison and I/O; the processing time of the most frequently used command is 0.060  $\mu$ s, which is used at about 10 points in every step. Therefore, the total response time of a PLC was designed within 4.0 ms.

As a result, it is expected that the permission is transmitted to the GUN within 8.243 ms. The processing time of the GUN deflector is designed to be about 5 ms. Therefore, the total response time required to stop the beam injection after the BIS detects a beam route mismatch is expected to be about 13.3 ms. Thus, it is evident that the system can transmit the permission within 16.6 ms.

Table 1: Response times of devices

| Device         | Response Time |
|----------------|---------------|
| L-PLC, M-PLC   | 0.586 ms      |
| E/O to E/O     | 0.025 ms      |
| Optical Module | 0.218 ms      |

### SUMMARY

We designed a reliable ASIS consisting of three independent interlock systems. Optical modules and a data collection module were also newly developed. We estimated the delay time of the transmission of permission signal through the ASIS system and then measured the signal propagation time of each device. The propagation time was found to be less than 16.6 ms, which satisfies the required time period. The construction of the ASIS will be completed by the end of July 2010, and its operation will begin in October 2010.

### REFERENCES

- [1] M. Kago, et al. "Design of the Accelerator Safety Interlock System for the XFEL in SPring-8", ICALEPCS '09, Japan, October 2009.
- [2] C. Saji, et al. "Upgrade of the Accelerator Radiation Safety System for SPring-8", ICALEPCS '09, Japan, October 2009.