

THE SPILL FEEDBACK CONTROL UNIT FOR J-PARC SLOW EXTRACTION

Shinya Onuma, Koh-ichi Mochiki, Tokyo City University, Tokyo.

Toshikazu Adachi, Ryotaro Muto, Hidetoshi Nakagawa, Hirohiko Someya, Masahito Tomizawa, KEK, Ibaraki

Akio Kiyomichi, SPring-8/JASRI, Hyogo, Japan

Takuro Kimura, Miyazaki University, Miyazaki. Koji Noda, NIRS, Chiba. Hikaru Sato, Tsukuba University of Technology, Ibaraki

Abstract

J-PARC (Japan Proton Accelerator Research Complex) is a new accelerator facility to produce MW class high power proton beams. In J-PARC main ring (MR) the proton beams is supplied hadron experimental facility by slow extraction to carry out various nuclear and particle physics experiments. A flat structure and small ripple noise are required for these beams to improve the efficiency of experiments and the availability of the accelerated beam.

We are developing a spill control system to realize the requirement. The spill control system consists of extraction quadrupole magnets and a new feedback unit. From October 2009 we started spill feedback operation in J-PARC MR.

INTRODUCTION

In J-PARC proton beams accelerated by MR is supplied Hadron Experimental Facility by using slow extraction and used for various nuclear and particle physics experiments [1]. The flat and small ripple noises are required for these beams to prevent pile-up of events in particle detectors or acquisition systems. We try to make amount of extracted beam constant in time structure by using new spill control system. The spill control system consists of quadrupole magnets and a new feedback unit.

In slow extraction of KEK-PS the analog circuit has been changed to a digital feedback device using DSP. We have big improvement about the spill feedback control. Based on the experience of KEK-PS, we developed the new feedback unit for J-PARC MR.

SPILL CONTROL

In J-PARC MR, the slow extraction is mainly carried out by an electrostatic septum (ESS) and magnetic septa. Two kinds of quadrupole magnets are additionally used to obtain better spill characteristic, extraction Q magnet (EQ) adjust the extracted beam to rectangular, ripple Q magnet (RQ) suppress the high frequent ripple components. Figure 1 shows the example of EQ and RQ control signal. The spill intensity tends to be lower than reference in the beginning and ending period of the extraction and tends to be higher than reference in the middle period of the extraction. EQ control signal must be high in the beginning and ending period and must be low

in the middle period. In RQ control signal must be the reverse phase of ripple noise [2].

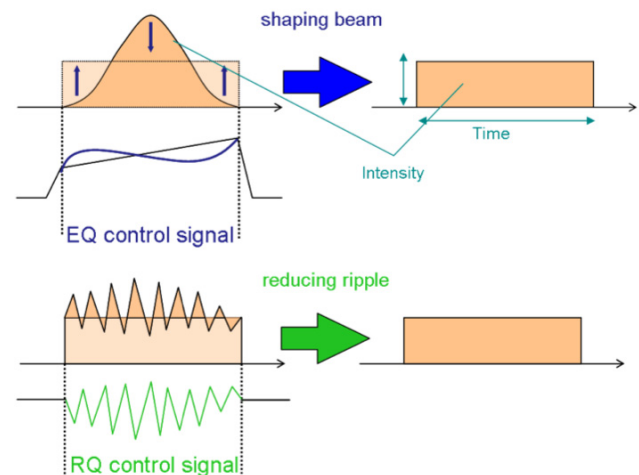

Figure 1: Constitution of spill feedback control

Figure 2 shows the block diagram of the feedback system. The extracted beams are adjusted by EQ magnets, a RQ magnet and feedback unit. Three input signals are a gate signal to enable feedback operation, a beam intensity signal to show the residual protons in the MR and a spill signal to show the amount of extracted proton beams. In the feedback unit these three signals are used to calculate the exciting pattern as EQ, RQ control signals.

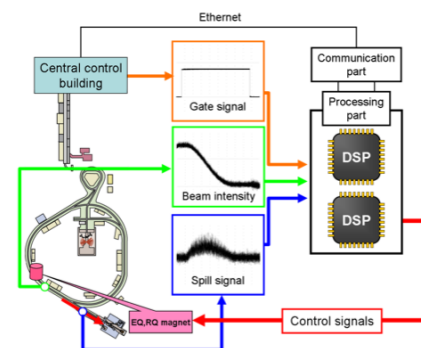

Figure 2: Block diagram of the spill feedback system

FEEDBACK UNIT

Figure 3 shows the block diagram of the spill feedback unit and figure 4 is the photograph of our feedback unit. Our feedback unit consists of three digital signal input ports for the gate signal, the spill signal and the beam intensity signal, two DSPs are TMS320C6713, dual port memories, FPGAs, SUZAKU-SZ410 and three output ports for control signals of the EQ and RQ magnets. A DSP for control (DSP (A)) assumes the calculation of the exciting current pattern for EQ and RQ magnets and a DSP for PSD (Power Spectrum Density) [4] (DSP (B)) assumes the analysis of the spectrum density from the spill signal. The dual port memory located between two DSPs is used to share the result of the analysis on second DSP and feedback control parameters used on first DSP. ADC's sampling clock is able to set from 1 kHz to 200 kHz in stages on the dipswitches. SUZAKU is used as a LAN interface for remote control to change the feedback parameters from central control room on EPICS.



Figure 4: Photograph of the spill feedback unit

Table 1: Specification of TMS320C6713

Clock	300Hz
Memory(Flash memory)	512kbyte
Memory(SDRAM)	16Mbyte

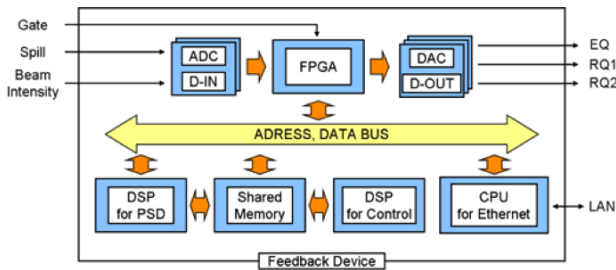

Figure 3: Block diagram of the spill feedback unit

FEEDBACK ALGORITHM

Figure 5 shows feedback algorithm of the slow extraction on the feedback unit. In the DSP(A) the maximum beam intensity is divided by extraction time and sampling clock to calculate the reference of spill which is extracted per sampling (SPL_ref). The difference value between the spill signal and the reference value is derived every sampling timing.

EQ magnet control signal is derived through a digital transfer function and variable gain. The digital transfer function was used in the digital feedback control system in KEK-PS because KEK-PS has same feature as a proton accelerator with J-PARC. The variable gain is used to increase the amount of extracted beam which tend to be low intensity in the beginning and ending of extraction and decrease the amount of extracted beam which tend to be high intensity in the middle of extraction. RQ magnet control signal is derived through digital filter which is dependent on the result of PSD and phase shift. PSD processed in DSP (B) is the spectrum analysis algorithm designed in our laboratory, and this spectrum analysis algorithm is suitable for real-time analysis than FFT (Fast Fourier Transform). The result of spectrum analysis about spill signal is written on shared memory, and used to adjust the parameter of digital filter and the phase shifter in DSP (A).

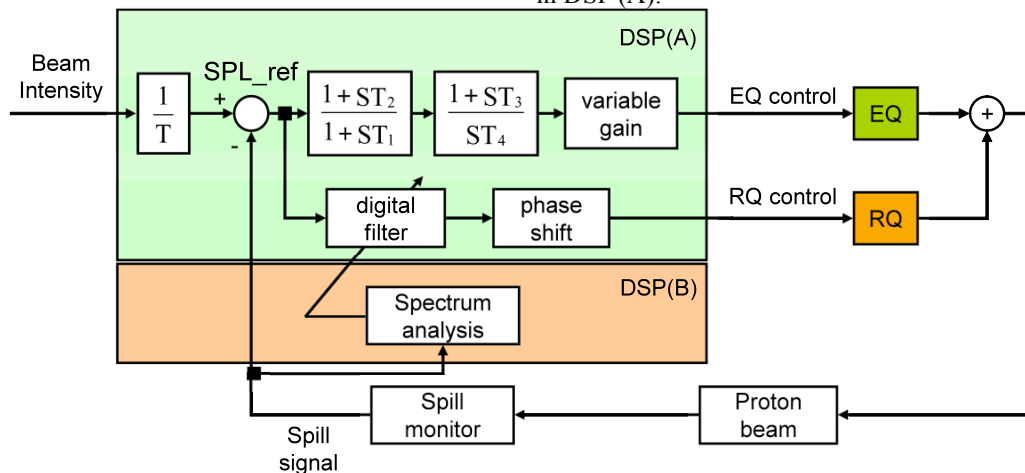

Figure 5: Block diagram of the digital spill feedback processing

BEAM COMMISSIONING

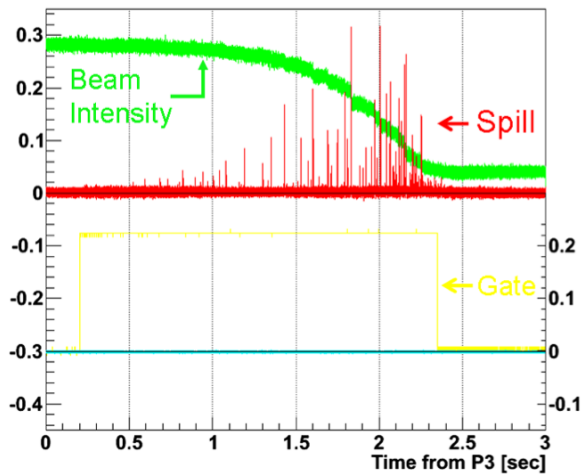

Figure 6: Beam Structure without EQ, RQ feedback

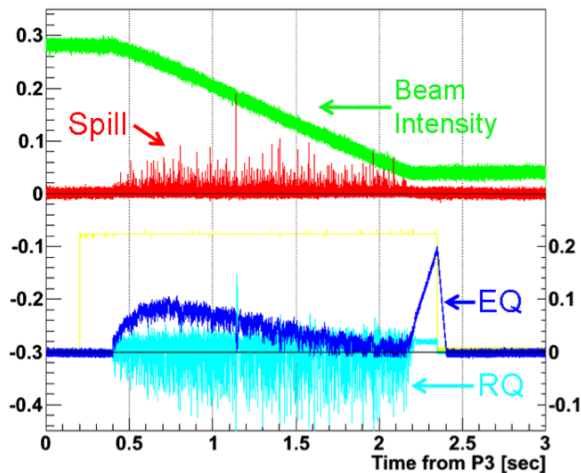

Figure 7: Beam Structure with EQ, RQ feedback

$$Duty\ Factor = \frac{\left[\int_0^T I(t) dt \right]^2}{\int_0^T dt \cdot \int_0^T I^2(t) dt} \quad (1)$$

We are carrying out the beam commissioning using our feedback unit and feedback algorithm in J-PARC MR and evaluate the beam structure by spill duty factor. Duty factor is calculated by the formula (1), and obtain the high value if the beam structure is close to the flat structure. Figure 6 shows the beam structure without EQ and RQ feedback. In this extraction we can see the spike structure of the spill signal and the spill duty factor was 2.7%. The beam intensity decreases in the shape of a slow curve and big ripple noise causes decreasing the beam intensity in an instant. Figure 7 shows the beam structure with EQ and RQ magnet control. In this

extraction we achieved flatter structure of the spill and better the spill duty factor was improve to 11.8 %. A liner reduction of beam intensity shows that the extraction is carried out by a constant amount. In the calculation of EQ control signal, 50 Hz or less ripple noise is reduced by using the 100Hz low pass filter.

CONCLUSION

We finished developing the new spill feedback unit which consists of two DSPs and carried out the experiments in J-PARC MR. In this experiments we confirmed the effect of our feedback unit and feedback algorithm. The feedback control improved the spill duty factor from 2.7 % to 11.8 %. In this machine time we confirmed the improvement of the beam characteristics by using the transverse RF experimentally. We expect the further improvement in the spill duty factor because we plan to introduce feedback control for Transverse RF and optimize the parameter of spill feedback control and variable gain for EQ control in the next machine time. I aim to further rejection of high frequent ripple noise by the development of spectrum analysis program for RQ feedback control and the digital filter which is controlled the pass band by the result of spectrum analysis.

REFERENCES

- [1] M. Tomizawa, "Status and Upgrade Plan of Slow Extraction from the J-PARC Main Ring", in this proceedings.
- [2] A. Kiyomichi, "Beam Spill Control for the J-PARC Slow Extraction", in this proceedings.
- [3] H. Nakagawa, et al., "Development of a Signal Processing Board for Spill Digital Servo System for Proton Synchrotron", Proceedings of ICALEPCS 2007, October, 2007, 430-432.
- [4] Y. Murata et al., "A New Method for Digital Power Spectrum Analysis", NIM 108 (1973) 243-252.
- [5] S. Onuma et al., "Development of Spill Feedback Control System for the J-PARC Slow Extraction", Proceedings of ICALEPCS 2009, October, 2009, TUP070.