

RECENT IMPROVEMENTS OF THE RF BEAM CONTROL FOR LHC-TYPE BEAMS IN THE CERN PS

H. Damerou, S. Hancock, M. Schokker, CERN, Geneva, Switzerland

Abstract

To cope with the large variety of different beams for the LHC, the RF beam control in the CERN PS has evolved continuously to improve its flexibility and reliability. Single-bunch beams, several different multi-bunch beams with 25, 50 or 75 ns bunch spacing at ejection for LHC filling, as well as two lead-ion beam variants are now regularly produced in pulse-to-pulse operation. The multi-bunch beam control for protons can be easily re-adjusted from $0.25 \cdot 10^{11}$ to $1.3 \cdot 10^{11}$ particles per ejected bunch. Depending on the number of bunches injected from the PS Booster, the length of the ejected bunch train may vary from 8 to 72 bunches. This paper summarizes recent improvements in the low-level RF systems and gives an outlook on the future consolidation.

INTRODUCTION

Since its original conception in the late 1990s [1, 2], the RF control system in the PS for beams destined for the LHC has been continuously evolving [3]. Although the production scheme in terms of RF manipulations has remained unchanged since the introduction of triple splitting [4], the underlying hardware has seen several optimizations for flexibility, reliability and ease of operation.

The different variants of the LHC-type beams with bunch spacings of 25, 50 or 75 ns are produced by combinations of triple and double bunch splittings on both the injection and extraction plateaus (Tab. 1).

Table 1: Longitudinal manipulations for the different variants of LHC-type beams. Each bunch (b) is split in two (2-split) or three (3-split) parts.

	LHC25ns	LHC50ns	LHC75ns
Injection	6 bunches on harmonic $h = 7$		
Flat-bottom manipulation	3-Split $h = 7, 14, 21$	3-Split	2-Split $h = 7, 14$
Acceleration	18b, $h = 21$		12b, $h = 14$
1st flat-top manipulation	2-Split $h = 21, 42$	2-Split	2-Split $h = 14, 28$
2nd flat-top manipulation	2-Split $h = 42, 84$	Rebucket	Rebucket $h = 28, 84$
Extraction	72b, 25 ns	36b, 50 ns	24b, 75 ns

A beam phase loop locks the vector sum of the RF voltage in the cavities to the average phase of the circulating bunches. During bunch splitting or rebucketing, the harmonic of the beam phase loop is switched to make sure

that the cavity return signal compared with the beam phase is always non-zero. Additionally, a radial loop [5] keeps the beam near the centre of the beam pipe until a synchronization loop takes over on the flat-top.

The RF control system is based on direct digital synthesizers (DDS) for the generation of signals to the RF cavities (2.8 – 10 MHz, 20 MHz, 40 MHz, 80 MHz, 200 MHz) and for the local oscillator signals. The phase detection and radial offset measurements of the phase and radial loops are performed with receiver front-ends converting beam and cavity return signals to a fixed intermediate frequency. The corrections from the various phase, radial and synchronization loops are then combined and applied as a frequency correction to the RF sources.

FORWARD PHASE CONTROL

During bunch splitting the RF voltage components applied to the beam should either be in phase or in counter-phase. However, due to a frequency-dependent delay of the RF amplifier chains, beam loading and imperfections in the low-level signal generation, the relative phases between RF harmonics need to be adjustable. Fig. 1 shows a mountain range plot of the first double splitting $h = 7 \rightarrow 14$ for the 75ns variant. Instead of the theoretical phase offset of

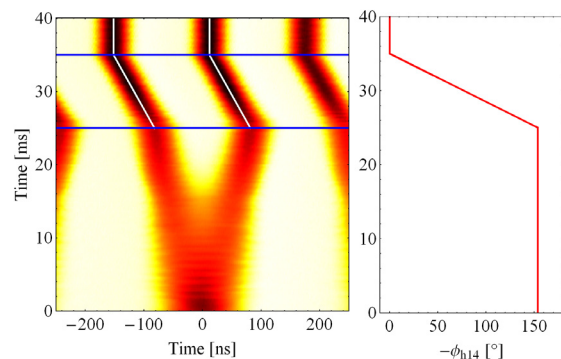

Figure 1: Double splitting $h = 7 \rightarrow 14$ on the flat bottom and subsequent return of the forward phase ϕ_{h14} to zero prior to acceleration.

$\phi_{h14} = 180^\circ$, a value of -154° is programmed to obtain symmetric splitting. To avoid any impact on acceleration and RF manipulations later in the cycle, the forward phase is slowly returned to zero within 10 ms.

The set-up of RF sources for such a manipulation is sketched in Fig. 2. A master DDS receives the digital revolution frequency including corrections from radial and beam phase loops. It generates a beam-synchronous signal at $h = 128$ as a clock for slave DDS, the so-called Multi-

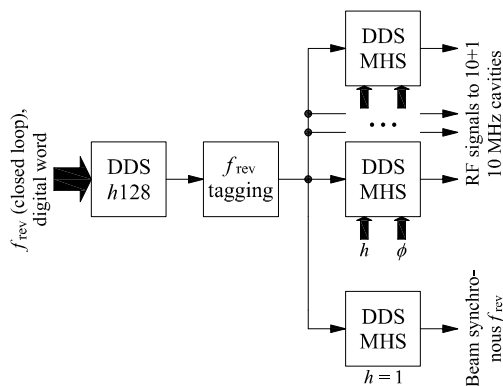

Figure 2: Simplified diagram of the master-slave DDS system to pilot the tuneable 10 MHz cavities during bunch splitting on the flat-bottom [6].

Harmonic Sources (MHS) [7], which can be programmed to any integer or non-integer harmonic number. The MHS have recently been upgraded with a digitally programmable phase offset register so that their output signal becomes

$$V_{RF}(t) \propto \sin(2\pi h f_{rev} t - h\Phi_n \pm \phi). \quad (1)$$

The first correction term in the argument of Eq. (1) compensates the time of flight of the beam to cavity n located at the azimuthal position Φ_n . The last term allows the output phase of the MHS to be freely programmed in the range of $\pm 180^\circ$. The sign of this new phase offset has been chosen such that programming a constantly increasing phase offset leads to a positive frequency offset $2\pi\Delta f = d\phi/dt$. The fact that the forward phases to the cavities are set back to zero after splitting, but not the beam-synchronous f_{rev} (see Fig. 2) explains why the bunches seem to move in the mountain range plot Fig. 1. The phase between beam and cavities remains fixed, coupled via the phase loop. Only the f_{rev} triggering the trace acquisitions moves with respect to the bunches.

It is worth noting that the forward phase control also turned out to be essential for the production of the lead ion beam for the LHC. Its lower velocity at injection requires the RF frequency to sweep by a factor of 2.5 (cf., only 10 % for protons) from injection to extraction. Proper programming of the forward phase to the RF cavities was required to compensate their frequency-dependent delay.

ADAPTING FOR INTENSITY CHANGES

As a pre-injector for the LHC, the PS must be able to provide beams covering an intensity range of at least 0.2 to $1.3 \cdot 10^{11}$ ppb at PS extraction [8]. Additionally, the batch length can be varied according to the number of bunches injected from the PS Booster. However, changing intensity may also affect the behaviour of the beam control loops. The phase measurement between cavity return sum and beam for the phase loop shows an intensity-dependent offset due to imperfections in the receiver front-ends. A remotely controllable offset adjustment has therefore been

06 Beam Instrumentation and Feedback

T04 Accelerator/Storage Ring Control Systems

introduced for each RF harmonic. Together with the forward phase programming mentioned above, the beam control can now be quickly re-optimized for a different intensity or batch length. Fig. 3 shows longitudinal profiles at extraction for two extreme cases of beams with 25 ns bunch spacing.

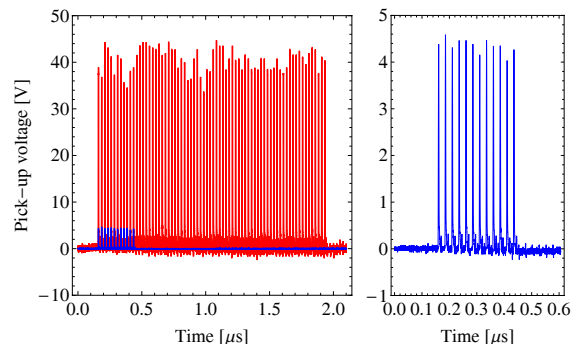

Figure 3: Longitudinal pick-up signal during the last turn for 72 bunches with almost $1.3 \cdot 10^{11}$ ppb (red, left plot) compared with 12 bunches with about 10 % of that intensity per bunch (blue, left/right plot). Note the different vertical scale of the right plot to magnify the low-intensity case.

REBUCKETING TO BUCKETS DERIVED FROM THE SPS RF

Upon arrival on the flat-top, the whole batch is synchronized with respect to the revolution frequency of the downstream SPS accelerator. As this coarse synchronization takes place at f_{rev} of the PS, each degree of phase error translates into 420° at 200 MHz, i.e., to more than one bucket at the RF frequency of the SPS. To improve precision, a fine synchronization loop is normally closed shortly before extraction, aligning the bunches to the external reference at $h = 84$. However, for the 50 ns and 75 ns variants, the fine synchronization loop can be avoided due to the rebucketing required to reach $h = 84$ prior to the bunch rotation at extraction (see Tab. 1). This process is robust against phase misalignments between the initial and final buckets. Hence the RF signal for the cavities on $h = 84$ can be directly derived (division by 5) from the RF signal from the SPS (Fig. 4). Any residual phase error from the coarse synchronization is decreased during rebucketing. Simulations indicate that the perturbation due to a phase error of up to $\Delta\phi_{h84} \simeq 60^\circ$ between the buckets before and after rebucketing is insignificant. Measurements in the SPS have confirmed that the phase jitter of the bunches at extraction is as small as when the fine synchronization loop is employed.

SIMPLIFICATION OF THE BEAM CONTROL STRUCTURE

The beam control for LHC-type beams comprises two different sets of RF sources. The MHS generate all har-

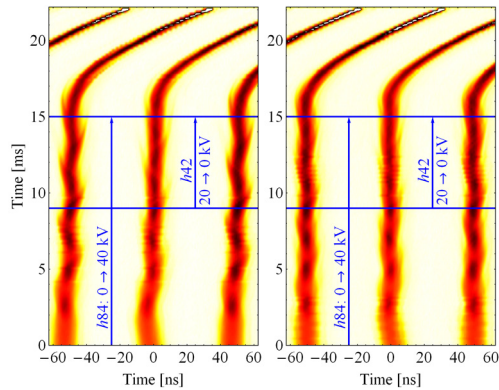

Figure 4: Mountain range measurement from rebucketing to extraction. Left: old scheme, involving beam phase, coarse and fine synchronization loops on $h = 84$. Right: rebucketing to an $h = 84$ (open-loop) bucket derived directly from the SPS RF. During the last 6 ms the trigger moves with respect to the bunches due to the extraction bump (forward RF to cavity is compensated in phase).

monics up to $h = 21$ (10 MHz) for the splittings on the flat-bottom and for acceleration. Higher harmonics ($h = 28, 42$ and 84), needed only on the flat-top, are derived by division from a DDS running at $h = 84$ (40 MHz). A sophisticated switching process is required to transfer the beam between these RF sources and several intensity-dependent adjustments are involved to synchronize them in frequency and phase. Instead, beam tests have started in 2008 to study the possibility of staying with the MHS system throughout the cycle. New frequency multipliers (without PLL) generate either $h = 42$ and 84 from $h = 21$ (LHC25ns, LHC50ns) or $h = 28$ and 84 from $h = 14$ (LHC75ns). They pilot the high-frequency cavities at 13.3/20 MHz and 40 MHz for the RF manipulations on the flat-top (Fig. 5). Longitudinal

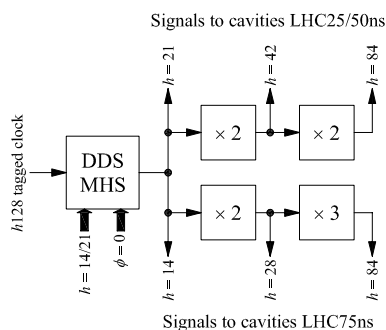

Figure 5: Generation of the RF signals for the 13.3/20 MHz and 40 MHz for the RF manipulations on the flat-top. The multipliers replace the DDS at $h = 84$ and the divider chains attached to it.

blow-up due to increased phase noise of the frequency multipliers is not observed as the RF manipulations on the flat-top are performed in less than 140 ms. Nor does the coupling of the MHS system to the measured dipole magnetic field (via the frequency programme) cause any problem.

Since 2009, the field measurement is integrated into the regulation [9] of the main magnet. This guarantees that a fixed field value within $\pm 10^{-5}$ T is distributed on the flat-top (though the true field might be different within the measurement error) and converted to a reproducible open-loop frequency by the frequency programme.

Beam has been successfully delivered to the SPS during a long machine development session and no unexpected side-effects of the new, simplified configuration of the beam control occurred. Moreover, the new configuration turned out to be more robust with respect to changes in beam intensity.

CONCLUSIONS

Various improvements have recently been implemented to the beam control for LHC-type beams in the PS. Forward and return offset adjustments allow to remotely optimize the beam control over a wide range of beam intensities. The complicated switching of RF sources with beam can be avoided, gaining in robustness without compromising beam quality. Unwanted interactions of beam phase and fine synchronization loops are removed by rebucketing to a rigid bucket. As the possibilities for further upgrades are rather limited with the present hardware, a more substantial upgrade to a fully digital beam control [10] is now being planned.

The authors would like to thank Thomas Bohl, Alan Findlay, Roland Garoby and Gerard Lobeau.

REFERENCES

- [1] R. Garoby, "Organization and Control of the PS Low Level RF in 1998", CERN PS/RF/Note 97-19, Geneva, Switzerland, 1996
- [2] A. Blas, R. Cappi, R. Garoby et al., "Beams in the CERN PS Complex after the Upgrades for LHC", EPAC'98, Stockholm, Sweden, 1998, pp. 505-507
- [3] R. Garoby, "LHC Proton Beams in the PS Complex: Status and Plans", 1st LHC Project Workshop, Chamonix, France, 2004, pp. 51-54
- [4] R. Garoby, "Demonstration of Triple Splitting in the CERN PS", EPAC'00, Vienna, Austria, 2000, pp. 304-306
- [5] S. Aumon, H. Damerou, S. Gilardoni, "Optimization of the Position of the Radial Loop Pickups in the CERN PS", *these proceedings*
- [6] R. Garoby, "Multi-harmonic RF source for the Anti-proton Production Beam of the AD", PS/RF/Note 97-10, CERN, Geneva, Switzerland, 1997
- [7] T. Anguelov, A. Ozturk, R. Garoby, "Multi-harmonic RF Source", PS/RF/Note 98-16, CERN, Geneva, Switzerland, 1998
- [8] M. Benedikt, "LHC Operational Beam Definitions for the Proton Injector Chain", LHC-OP-ES-0002 rev 1.0, CERN, Geneva, Switzerland, 2004
- [9] Q. King, M. Veenstra, private communication, 2009
- [10] M. E. Angoletta, A. Blas, A. Butterworth et al., "CERN's PS Booster LLRF Renovation: Plans and Initial Beam Tests", *these proceedings*