

# CONSTRUCTION AND BENCH TESTING OF A ROTATABLE COLLIMATOR FOR THE LHC COLLIMATION UPGRADE\*

Jeffrey Claiborne Smith<sup>†</sup>, Lewis Keller, Steven Lundgren, Thomas Markiewicz  
(SLAC, Menlo Park, California)

## Abstract

The Phase II upgrade to the LHC collimation system calls for complementing the 30 high robust Phase I graphite secondary collimators with 30 high Z Phase II collimators. The Phase II collimators must be robust in various operating conditions and accident scenarios. This paper reports on the final construction and testing of the prototype collimator to be installed in the SPS (Super Proton Synchrotron) at CERN. Bench-top measurements will demonstrate that the device is fully operational and has the mechanical and vacuum characteristics acceptable for installation in the SPS.

## THE COPPER ROTATABLE COLLIMATOR DESIGN

The principle function of the LHC collimation system is to protect the superconducting magnets from quenching due to particle losses. The collimation system must absorb upwards of 90 kW in the steady state operating condition (1 hr beam lifetime) and withstand transient periods where up to 450 kW is deposited for no more than 10 seconds. The system must also be robust against an accident scenario where up to 8 full intensity bunches impact on one collimator jaw due to an asynchronous firing of the beam abort system imparting 1 MJ over 200 ns. The high Z material of the phase II collimators provides better collimation efficiency compared to the low Z graphite phase I collimators but will not withstand the impact of the 8 full intensity bunches in the accident scenario without permanent damage, so a rotatable jaw has been designed which will be recoverable. Composed of two cylindrical jaws, if a beam happens to hit a jaw it can be rotated to introduce a clean surface for continued operation. 20 flat facets on the cylindrical jaw surface is sufficient to last the lifetime of the LHC. Details of the jaw design and construction can be found in [1] and [2]. The final jaw design is illustrated in figure 1.

Details of the device can be seen in figure 2 which shows the jaw end, cylindrical vacuum chamber and transition pieces. The Jaw is supported by a thin stainless steel bar that can flex and take up the thermal expansion of the jaw without the need of a universal joint. The use of a cylindrical vacuum chamber simplifies the design and construction and facilitates the use of thinner chamber walls compared to a rectangular design resulting in less radiation activation.

\*Work partially supported by the US Department of Energy through the US LHC Accelerator Research Program (LARP).

<sup>†</sup>js344@slac.stanford.edu

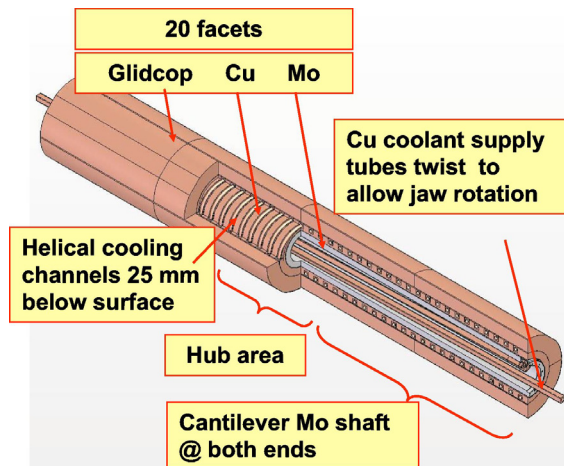

Figure 1: Cutaway of Jaw showing outer jaw surfaces and cooling tube routed through the center of the molybdenum shaft.

A temperature probe is positioned near the end of the jaw on the transition piece to monitor the temperature of the jaw during beam cleaning. The sensor would ideally be placed directly on the jaw but this proved impractical. Each end of the device incorporates a BPM assembly housing standard LHC warm section buttons. These BPMs will be used to align the jaw relative to the beam with a resolution of 25 microns or better. The rotation mechanism described in other papers [1] allows for precision alignment of the jaw via use of a Geneva Gear.

The RF foils will be 250 micron thick beryllium-copper sheets wide enough to completely block the rotation mechanism and supports from the line of sight of the beam. Studies have shown that a large RF foil is necessary to limit longitudinal trapped mode heating [4]. A sliding contact between the rotating jaw and the fixed RF foil is necessary. This contact uses 300 conducting rhodium coated 1 mm stainless steel ball bearings. The bearing race is bare copper so the rhodium coating on the balls is to prevent cold welding. The target DC resistance across the RF contact is 1 mOhm. A 4-wire measurement was performed to measure the contact resistance for both jaws and the resistance was found to be within acceptable levels. However, the contact resistance was highly dependent on the bearing race tightness and machine smoothness. We are investigating modifications to this setup to make a more resilient sliding contact. An additional set of ceramic ball bearings about the central molybdenum hub are to support the load of the jaw during rotation. Impedance considerations and

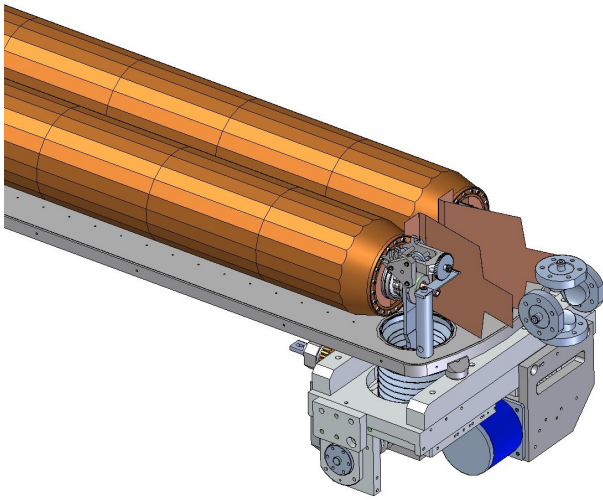

Figure 2: Jaw end showing RF transition pieces and rotation mechanism.

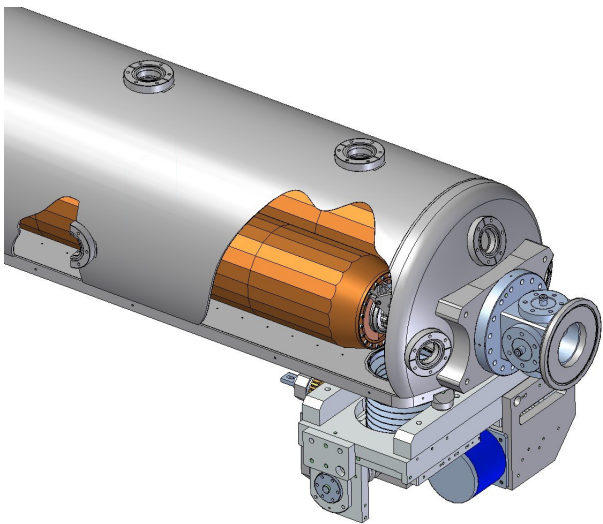

Figure 3: Full collimator prototype showing viewport and drive tables.

testing of the device is presented in another paper [5]. The full device including vacuum tank and drive table is shown in figure 3. The viewports are to observe the jaws and rotation mechanism during operation and to detect any damage during beam impact studies.

### ALIGNMENT, FLATNESS AND ROTATION PRECISION

The 1 meter long jaws being collimation surfaces require very good flatness and alignment with the beam to 25 microns. Each jaw was placed on a CMM to find three properties: the surface profile for each facet, the axis of rotation and concentricity of each facet and the gravity sag. The gravity sag was found to be minimal at just a couple microns due to the design having a central hub only sup-

porting the outer jaw at the center (see figure 1). The first jaw (RC0) had an average facet flatness of 38.5 microns with the worst facet being 50.6 microns. The jaw generally exhibits a bowed shape due to the machining method of the facets. The method was modified for the second jaw (RC1) which has an average flatness of 8.25 microns with the worst facet being 10.8 microns. It has therefore been shown that the 25 micron flatness specification is achievable. Each facet also exhibits a geometric angle error of less than 0.017 degrees which is also within requirements. The rotation axis was however measured to be off from the geometric axis of the jaw. This means that when a new facet is rotated into operating position a correcting must be applied to the positioning of the jaw to keep the jaw aligned to within 25 microns to the beam. A “look-up” table has been created that dictates the correction for each facet after rotation. The largest correction for any facet is 46 microns and the correction can easily be applied with the drive table. The rotation concentricity is dependent on the machining and alignment of the ceramic bearing race and for future jaws we will attempt to eliminate the need for the correction table.

In addition to requiring a facet flatness of 25 microns the facet must also be positioned to within 25 microns. The drive mechanism, identical to the CERN Phase I collimator drive table, has been demonstrated to position the jaws to within a couple of microns and the LVDTs have a position accuracy of within 1 micron and a long term stability of within  $\pm 10$  microns [3]. However, the rotation mechanism must also rotate the facet position so that the 25 micron flatness spec is sustained after rotation. The facet flatness of 12 microns RMS is added in quadrature with the facet angle error and simple geometry can then be used to calculate the rotation accuracy of the facet considering the beam will only directly come into contact with the center 8 mm of the 20 mm facet. The resultant angle precision is 0.154 degrees. The rotation mechanism has an angle precision of 0.035 degrees, therefore the desired alignment is achievable. The worm gear must also have minimal backlash when meshing with the driven wheel on the jaw. 0.154 degrees translates into a precision in the backlash on the worm gear to within 75 microns. Backlash less than 75 microns is easily achievable.

### FABRICATION AND ASSEMBLY OF SPS PROTOTYPE

Assembly of the SPS prototype is ongoing. The jaws have been mounted on the baseplate as shown in figure 4 and the rotation mechanism has been tested. Figure 5 shows the rotation mechanism attached to one jaw undergoing rotation tests. Critical to accurate rotation is ensuring the ratchet actuator actuates the ratchet every time. The actuator appears to have reliable long-term operation but a probe to test for complete actuation during operation is being investigated. Fortunately, by design the Geneva drive allows for several missed ratchets before the facet begins

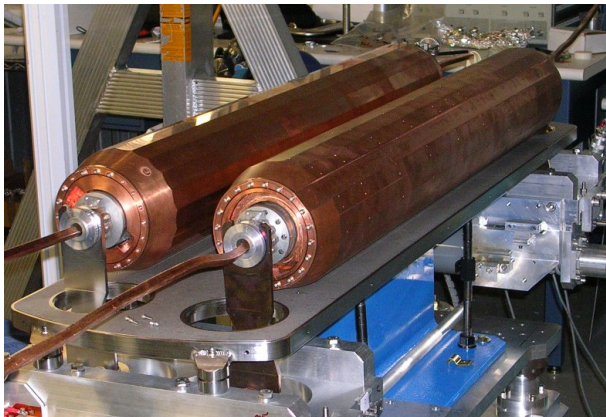

Figure 4: The two jaws mounted on the base-plate.

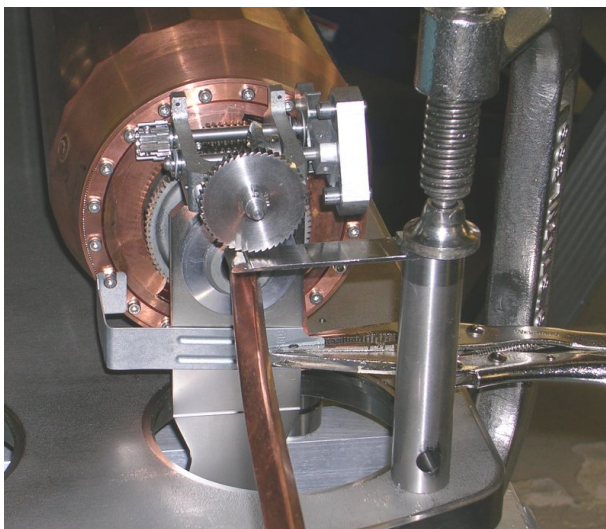

Figure 5: View of rotation mechanism attached to Jaw mounted on base plate.

to move out of alignment. Figure 6 is of the full collimator with vacuum tank and BPM assemblies mounted on the base plate but not yet welded.

### MECHANICAL TESTING

Prior to installation in the SPS the prototype must pass a series of tests and verifications before it will be permitted to be installed in the SPS. Precision positioning and rotation of the jaw and calibration of the jaw surface to a fixed reference point will be achieved by assembling the collimator without the cylindrical tank on a CMM and positioning and rotating several facets into operating position. The rotation axis concentricity may be highly dependent on the bearing race position and so it is to be measured after final assembly. The device is to also be oriented in the 90 degree position to test the capability of the stepper motors to position the jaws when working against the full weight of the jaw. Vacuum tests will be performed to SLAC PEP-II standards. All components will be cleaned prior to vacuum

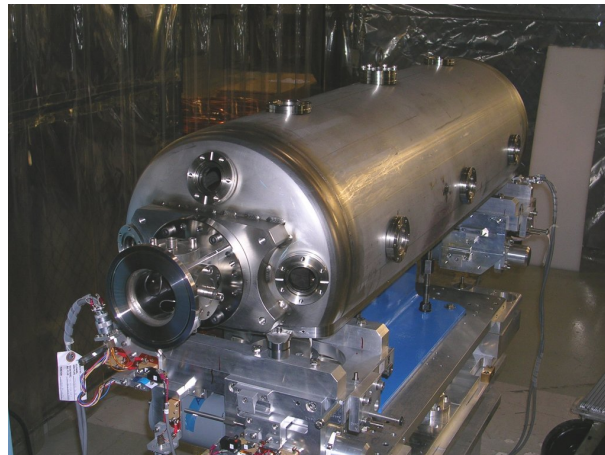

Figure 6: The full collimator in tank with BPM assemblies.

bake-out. The jaws will be hydrogen fired, other internal components will be vacuum fired and the tank and base-plate will be chemically cleaned. The mechanical stops and limit switches are to be properly positioned so that the jaws are protected from accidental collisions. Finally, a reference point outside the tank will be used to align the jaws with the beam line reference. Once shipped to CERN, the device will undergo a standard LHC collimator testing regimen and be equipped with electrical and water fittings to interface in the SPS systems.

### ACKNOWLEDGMENTS

The authors are greatly indebted to numerous people who have aided in the fabrication and design of the rotatable collimator including Ralph Assmann, Oliver Aberle, Alessandro Bertarelli, Alessandro Dallocchio, Fritz Caspers, Elias Metral and Gianluigi Arduini at CERN.

### REFERENCES

- [1] Smith, J. *et al.*, "Design of a Rotatable Copper Collimator for the LHC Phase II Collimation Upgrade," Proceedings EPAC08 MOPC096 (2008)
- [2] Keller, L. *et al.*, "LHC Phase II Rotatable Collimator - RC1 Conceptual Design Report," see: <http://www-project.slac.stanford.edu/ilc/larp/rc/documentation/documentation.htm> (2009)
- [3] Masi, A. "Motorization and Low-Level Control of the LHC Collimators," see: <http://indico.cern.ch/conferenceDisplay.py?confId=68258>
- [4] Xiao, Liling, *et al.*, "Wakefield Study for SLAC Rotatable Collimator Design for the LHC Phase II Upgrade," Proceedings IPAC10 TUPEC079 (2010)
- [5] Smith, J. *et al.*, "Bench-Top Impedance and BPM Measurements of a Rotatable Collimator for the LHC Collimation Upgrade," Proceedings IPAC10 TUPEB079 (2010)