

DUAL-HARMONIC PHASE CONTROL IN THE J-PARC RCS

Fumihiko Tamura*, Alexander Schnase, Masahito Yoshii,
 Chihiro Ohmori, Masanobu Yamamoto, Masahiro Nomura, Makoto Toda,
 Hiromitsu Suzuki, Taihei Shimada, Keigo Hara, Katsushi Hasegawa
 J-PARC Center, KEK & JAEA, Tokai-mura, Naka-gun, Ibaraki-ken, Japan 319-1195

Abstract

The wide-band RF cavities in the J-PARC RCS are running in the dual-harmonic operation, in which each single cavity is driven by a superposition of the fundamental and the second harmonic RF signals. By the dual-harmonic operation large amplitude second harmonic signals for the bunch shape manipulation are generated without extra cavities. The phase control of the second harmonic RF is a key for the bunch shape manipulation. The fundamental RF signal is controlled by the phase feedback loop to damp the dipole oscillation. The second harmonic is locked to the phase of the vector-sum phase of the fundamental RF signals. We present the system detail and the performance in the beam operation of the RCS.

INTRODUCTION

The bunch shape manipulation is very important in a high-current proton synchrotron to alleviate the space-charge tune shift. The second harmonic RF is useful for the manipulation. In the rapid cycling synchrotron (RCS) of the Japan Proton Accelerator Research Complex (J-PARC) [1, 2], the second harmonic RF is realized by the dual-harmonic operation [3, 4], in which each single cavity is driven by a superposition of the fundamental ($h = 2$) accelerating RF and the second harmonic ($h = 4$) RF signals. Because of the limited space of the RCS ring, only by the dual-harmonic operation the large amplitude second harmonic RF can be generated. For dual-harmonic operation, we employ wide-band cavities loaded by magnetic-alloy cores. The Q-value of the cavities is in the order of 2.

The phase control of both of the fundamental and the second harmonic RF is a key for the stable acceleration of the high-current proton beams. The dipole oscillation causes beam losses not only by the aperture limit of the dispersion-peak in the ring, but also by the tune spread due to the chromaticity, especially in the case of the high beam current. The dipole oscillation is damped by the phase feedback loop for the fundamental RF. For the bunch shape manipulation, the RF bucket shape control is essential. The relative phase of the second harmonic to the fundamental must be controlled to generate the desired RF bucket shape composed of the fundamental and the second harmonic RF. The second harmonic RF has its own phase loop.

In the following we describe the system details and the performance in the beam operation.

Table 1: Parameters of the J-PARC RCS and the RF System

circumference	348.333 m
energy	0.181–3 GeV
accelerating frequency	0.938–1.671 MHz
harmonic number	2
maximum RF voltage	450 kV
repetition rate	25 Hz
No. of cavities	11
Q-value	2

PHASE FEEDBACK SYSTEM

The phase feedback system is implemented as a part of the low-level RF (LLRF) control system. We developed a full-digital LLRF control system. The LLRF system overview is described in [5].

The phase control refers to the vector-sum of the cavity voltages. The schematic of the generation of the vector-sum is shown in Fig. 1. The cavity voltage monitor signals are input to the RFG (RF Generator) modules. The RFG module contains the dual-harmonic AVC described in [3]. The monitor signals are converted to digital signals, and led into the fundamental ($h = 2$) and the second harmonic ($h = 4$) detection blocks. In these blocks, I/Q vectors of selected harmonics are generated by using the phase reference signals, which are distributed to all modules [5]. The I/Q vectors are rotated according to the cavity position in the ring, and sent to the SUM module.

In the SUM module, the I/Q vectors of ($h = 2, 4$) from RFG01 to RFG11 are summed. The summation of the vectors is fed into the coordinate transformer, which calculates

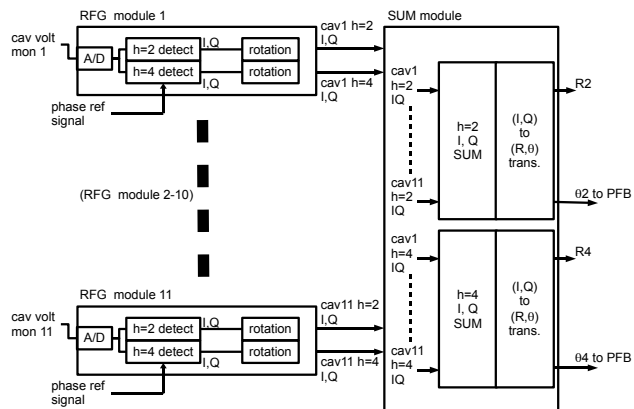

Figure 1: Schematic diagram of the vector-sum.

* fumihiko.tamura@j-parc.jp

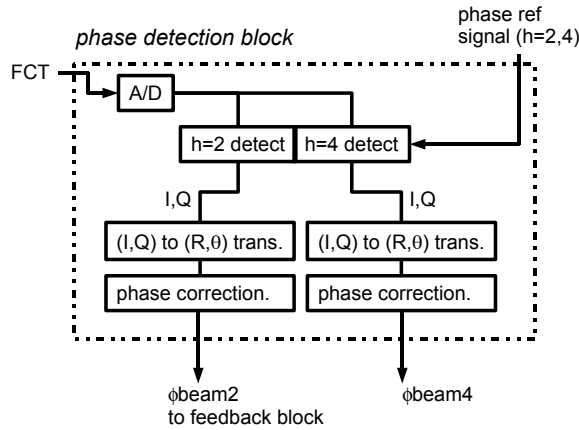

Figure 2: Schematic of the phase detection block in the PFB module.

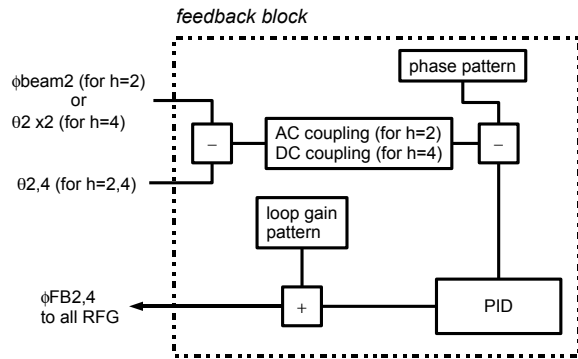

Figure 3: Phase feedback diagram. For the fundamental RF ($h = 2$), ϕ_2 and θ_2 is compared. For the second harmonic ($h = 4$), θ_4 is compared with $\theta_2 \times 2$.

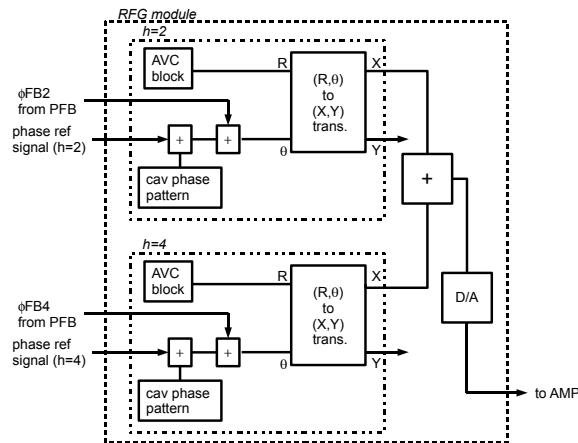

Figure 4: Generation of dual-harmonic RF signal using the feedback signals $\phi_{FB2,4}$.

the amplitudes (R_2, R_4) and the phases (θ_2, θ_4) from I/Q vectors. The vector-sum phases (θ_2, θ_4) are sent to the PFB (Phase FeedBack) module.

The diagram of the phase detection block in the PFB module is illustrated in Fig. 2. In the phase detection block, the beam signal from the fast current transformer (FCT) is converted to a digital signal. The digitized signal is led into the ($h = 2$) and ($h = 4$) detection blocks and the coordinate transformers, which are similar to the RFG. After applying the phase correction pattern, the fundamental ($h = 2$) beam phase (ϕ_{beam2}) is sent to the feedback block.

The schematic diagram of the feedback block is shown in Fig. 3. The feedback blocks for ($h = 2$) and ($h = 4$) work differently. Since the role of the phase feedback for the fundamental ($h = 2$) is to damp the dipole oscillation, the ($h = 2$) feedback block compares the beam phase (ϕ_{beam4}) and the vector-sum cavity phase (θ_2). Also, the AC coupling is applied.

On the other hand, the second harmonic ($h = 4$) is locked to twice of the fundamental ($h = 2$) cavity phase ($\theta_2 \times 2$) to get the desired bucket shape by superposition of the fundamental and second harmonic. For this purpose, the DC coupling is used.

In both cases of ($h = 2, 4$), the output of the AC/DC coupling circuit is compared with the phase patterns. The error signals are led into the PID circuit. Finally, by multiplying the loop gain pattern, the feedback signals $\phi_{FB2,4}$ are generated. The signals $\phi_{FB2,4}$ are distributed to all RFG modules via the back-plane. As illustrated in Fig. 4, the RFG module generates the dual-harmonic RF signal of the phase of the sum of the phase reference signal and the $\phi_{FB2,4}$. The amplitudes of the harmonics are controlled by the AVC blocks. The fundamental ($h = 2$) and the second harmonic ($h = 4$) RF signals are summed. The digital RF signal is converted into the analog RF signal. For each of 11 systems, the RF signal is sent to the amplifier to drive the cavity. Therefore, all cavity phases are modulated in a parallel direction.

PERFORMANCE

In the J-PARC RCS, the “delta-R BPM” is located near the dispersion peak to see the matching between the bending field and the RF frequency. The RF frequency pattern is tuned so that the delta-R signal is small. The dispersion of the RCS is about 4.8 m near the delta-R BPM. The delta-R signal also shows the longitudinal dipole oscillation. In Fig 5, the delta-R signals for a full acceleration period without and with the phase feedback of the fundamental RF are plotted. In this case the proportional gain and differential gain are zero, and the integral gain is 0.006. The large amplitude dipole oscillation, which corresponds to a momentum deviation of $dp/p \sim \pm 0.1\%$, remains until end of the acceleration without the phase feedback, while it is rapidly damped out with the phase feedback.

For longitudinal painting, the second harmonic RF is applied from the beginning of the injection until the early

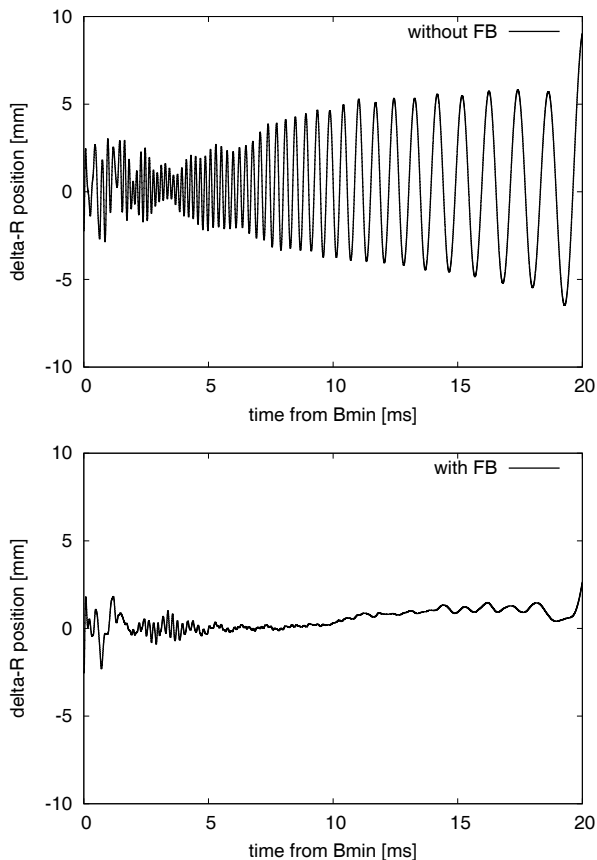

Figure 5: The delta-R BPM signal. Top: without phase feedback of the fundamental RF, bottom: with phase feedback.

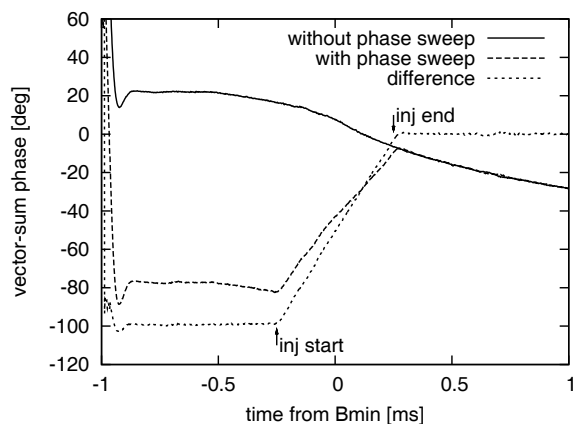

Figure 6: The measured phases of the second harmonic vector-sum voltages. Without and with the second harmonic phase sweep (100 degrees). Also, the difference between without and with the phase sweep is shown.

stage of the acceleration at 2 ms after B_{\min} . Without the second harmonic phase sweep described in [4], the phase of the second harmonic relative to the fundamental is locked to twice of the synchronous phase ($\phi_s \times 2$), so that the zero-cross of the second harmonic is located at the center of the bunch.

In case of the second harmonic phase sweep, the second harmonic phase relative to the fundamental was swept as

$$\phi_{(h=4)} = \frac{\phi_{\text{sweep}}}{T_{\text{inj}}} \left(t - \frac{T_{\text{inj}}}{2} \right) - 2\phi_s, \quad (1)$$

where $\phi_{(h=4)}$ is the second harmonic phase, ϕ_{sweep} the sweep range, T_{inj} the duration of the injection, and ϕ_s the synchronous phase of the beam. At the beginning of the injection, the second harmonic phase has a offset relative to the phase $2\phi_s$, and the offset is reduced linearly. It goes to zero at the end of the injection. By the phase sweep, the bucket shape is modified during the injection period to improve the bunching factor, which is defined as the ratio between the average and peak current.

The measured phases of the second harmonic of the vector-sum cavity voltages near the injection period are shown in Fig 6. In the graph, the phases in the cases without and with the phase sweep with the range of 100 degrees, and the difference between with and without, which corresponds to the sweep phase itself, are shown. The sweep is as expected, thus, the phase feedback of the second harmonic RF works well.

SUMMARY

We summarize the article as follows. The system detail of the dual-harmonic phase control system in the J-PARC RCS, which is necessary to accelerate the high intensity proton beam, is described. The fundamental RF phase feedback damps the dipole oscillation. The second harmonic phase feedback locks to the phase of the fundamental RF to generate desired RF bucket shape. The system works well for both of the fundamental and the second harmonic.

REFERENCES

- [1] "JHF accelerator design study report." KEK-Report 97-16, 1997.
- [2] "Accelerator technical design report for J-PARC." JAERI-TECH 2003-044, 2003.
- [3] F. Tamura *et al.*, "Dual-harmonic auto voltage control for the rapid cycling synchrotron of the Japan Proton Accelerator Research Complex," *Phys. Rev. ST Accel. Beams*, vol. 11, 072001, Jul 2008.
- [4] F. Tamura *et al.*, "Longitudinal painting with large amplitude second harmonic rf voltages in the rapid cycling synchrotron of the Japan Proton Accelerator Research Complex," *Phys. Rev. ST Accel. Beams*, vol. 12, 041001, Apr 2009.
- [5] F. Tamura *et al.*, "Low Level RF Control System of J-PARC Synchrotrons," in *Proceedings of the Particle Accelerator Conference (PAC 2005)*, pp. 3624–3626, 2005.