

THE INJECTION SYSTEM OF THE INFN-SUPERB FACTORY PROJECT PRELIMINARY DESIGN

R. Boni, S. Guiducci, M. A. Preger, P. Raimondi, INFN-LNF, Frascati, Italy
 O. Dadoun, F. Poirier, A. Variola, LAL/IN2P3, CNRS Orsay, France
 A. Chancé, CEA, Gif-sur-Ivette, France; J. Seeman, SLAC, CA 94025, USA

Abstract

The ultra high luminosity B-factory (SuperB) project of INFN requires a high performance and reliable injection system, providing electrons at 4 GeV and positrons at 7 GeV, to fulfil the very tight requirements of the collider. Due to the short beam lifetime, continuous injection of electron and positron bunches in both LER and HER rings is necessary to maintain an high average luminosity. Polarized electrons are required for experiments and must be delivered by the injection system, due to the beam lifetime shorter than the ring polarization build-up: they will be produced by means of a SLAC-SLC polarized gun. The emittance and the energy spread of the e^-/e^+ beams are reduced in a 1 GeV Damping Ring (DR) before injection in the main rings. Two schemes for positron production are under study, one with e^-/e^+ conversion at low energy (< 1 GeV) and one with conversion at 6 GeV and a recirculation line to bring the positrons back to the DR. Acceleration through the Linac is provided by a 2856 MHz RF system made of travelling wave (TW), room temperature accelerating structures.

THE INJECTION SYSTEM PROCESS

The injection system of the SuperB project [1] proposed by the Istituto Nazionale di Fisica Nucleare (INFN, Italy), aims to provide electrons and positrons charge with large margin to keep the current and the luminosity almost constant during operation. The beam lifetime of the SuperB factory rings will be about 4+5 minutes. With 978 bunches/ring and a e^+ bunch population of $5 \cdot 10^{10}$, the particles lost per second per ring are about $1.8 \cdot 10^{11}$. With 5 injected bunches per pulse and an injection rate of 25 Hz per ring, each injected bunch must provide a charge of about 240 pC ($1.5 \cdot 10^9$ particles/bunch) that is about 3%

of the SuperB stored bunch charge. This value is about 60 times lower than the bunch charge emitted by the gun.

The layout of the SuperB injection system, in the low energy e^+ production scheme, is shown in Fig. 1 with a schematic view of the injection/extraction beam lines to/from the DR.

The SuperB injector consists of an electron source, a low energy S-band linac, a positron production with capture system utilizing a high Z-target (tungsten) with an adiabatic matching device (AMD) and an L-band positron linac. The low charge electron bunches for injection into the e^- LER ring pass through a hole in the target by means of a magnetic chicane. A single 1 GeV DR is utilized to reduce beam emittance and energy spread of both e^- and e^+ bunches before acceleration to the respective final energies.

The injection process is the following:

1) a train of five 1 nsec long, 4.2 nsec apart, e^- bunches is generated by the gun, bunched to 10 psec and accelerated up to the W target. The emerging e^+ bunches are captured, accelerated to 1 GeV through the L-band linac and injected into the damping ring. The damped e^+ bunch train is then extracted after 20 msec, compressed and accelerated to the final 6.7 GeV energy by means of a 5.7 GeV S-band linac.

2) simultaneously to the e^+ extraction from the DR, another train of e^- bunches is generated, compressed to 10 psec and, passing through the hole in the target, accelerated to 1 GeV along the S-band and L-band linacs and injected in the DR. The damped e^- bunch train is extracted after 20 msec and, in turn, accelerated to the final 4 GeV energy.

The main rings are filled alternately at 25 Hz. The klystrons operate at 50 Hz.

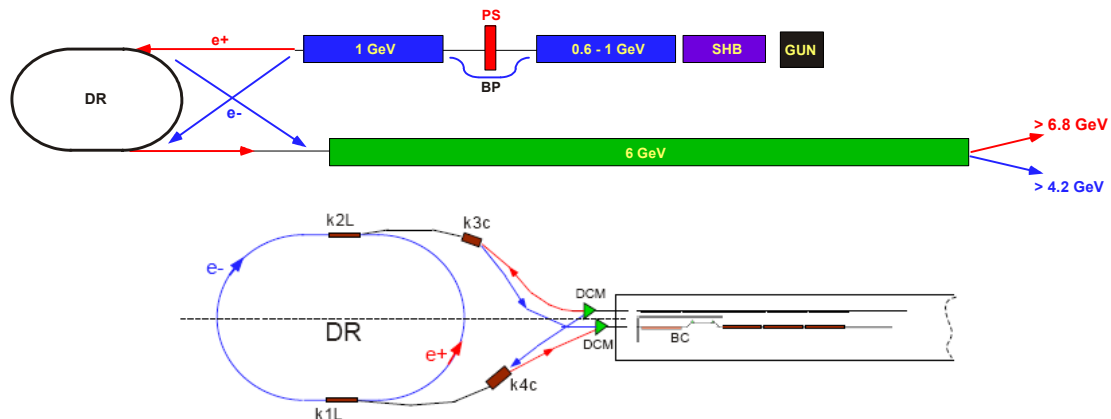

Figure 1: top) SuperB injector schematic layout; bottom) scheme of the transfer lines to/from the Damping Ring.

Fig. 2 shows the timing process of the SuperB injection system.

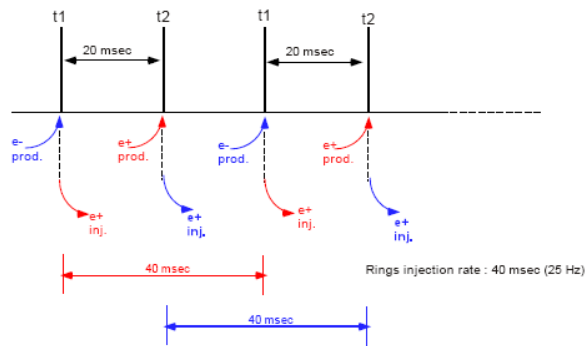

Figure 2: Timing process.

THE INJECTOR LAYOUT

The electron gun consists of a SLAC GaAs Cathode polarized gun [2], illuminated by a frequency-doubled Nd:YLF, linearly polarized laser system. The gun produces 1 ns pulses with intensity up to $1 \cdot 10^{11}$ electron/pulse at 120 Hz repetition rate. The electrons from the gun are transversely polarized. The vertical polarization, averaged over the electron bunch, is expected to be $\approx 88\%$. To be captured and accelerated by the S-band linac, the electron bunches are compressed down to 10 psec with a Sub-Harmonic Bunching system (SHB) following the gun. The SHB consists of 2 standing wave cavities operating at 238 MHz and 476 MHz, the 12th and the 6th sub-harmonics of 2856 MHz respectively, followed by an S-band buncher. The SHB is followed by an S-band room temperature 0.6 GeV linac that utilizes three 60 MW klystrons, feeding three TW accelerating sections with pulse compressor. The energy gain per RF station is 220 MeV. The positron target is then followed by a 1 GeV, L-band linac that helps in increasing the positron capture and transport. L-band 20 MW klystrons and accelerating guides operate already at 1300 MHz [3] but re-designing them at 1428 MHz should not present technical hitches.

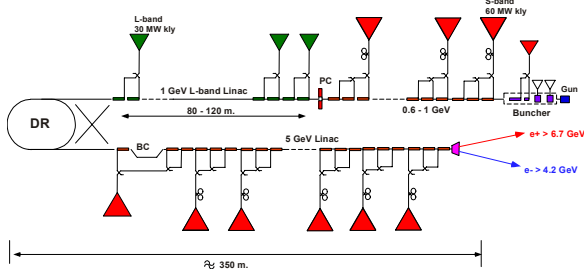

Figure 3: RF layout of the SuperB Injector.

After extraction from the DR, the bunches are shortened by a magnetic bunch compressor (BC) and accelerated to the respective nominal energies along the 2856 MHz linac composed by 87 accelerating sections, powered in groups of three to about 23.5 MV/m. In the

electron mode, 12 out of 29 RF stations of the high energy linac are switched off so we can accelerate the beam to 4.2 GeV without intermediate extraction and a dedicated transfer line.

Positron production

The positron production strategy is illustrated in another paper of this conference proceedings [4]. Positrons production and capture scheme are based on low energy electrons up to 1 GeV and an adiabatic matching device followed by the L-band linac. A total accepted yield of about 20 % can be obtained.

Damping Ring

The lattice is based on the same kind of low emittance cell adopted for the SuperB main rings. The phase advance per cell of $0.75 \cdot 2\pi$ in the horizontal plane and $0.25 \cdot 2\pi$ in the vertical one helps in cancelling the non linear contributions of the chromaticity correcting sextupoles. This kind of cell, due to the small dispersion in the dipoles, yields a low value of the momentum compaction, and therefore a short bunch length, which, however, must be further reduced by a bunch compression system at extraction. Betatron damping times slightly larger than 7 msec ensure adequate reduction of the injected beam emittance and energy spread at the maximum repetition rate of 50 Hz foreseen by the the injection scheme. Fig. 4 shows a schematic layout of the ring, while Table 1 summarizes the main parameters of the damping ring. Fig. 5 shows the optical functions of the ring. Electrons are injected at one of the two septa (S in the figure) and extracted from the other one. Positrons follow the opposite path with the same fields in the ring. A train of 5 consecutive bunches from the Linac are stored in the damping ring at each injection pulse by means of the fast kicker, indicated with K in the figure, downstream the septum, damped and finally extracted by the second kicker upstream the extraction septum.

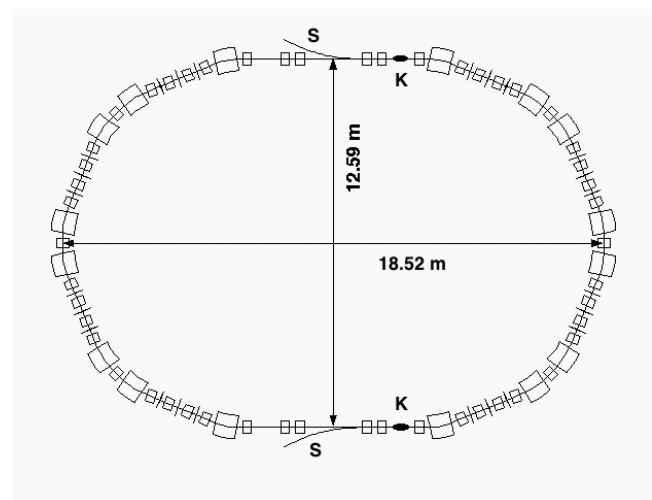

Figure 4: Damping ring layout.

Table 1: Damping ring parameters

Parameter	Units	Value
Energy	GeV	1.0
Circumference	m	51.0
Horizontal betatron tune		7.403
Vertical betatron tune		2.717
Uncorrected hor. chromaticity		-11.5
Uncorrected vert. chromaticity		-6.5
Hor. phase advance per cell	degrees	270
Vertical phase advance per cell	degrees	90
Maximum horizontal beta	m	7.9
Maximum vertical beta	m	7.3
Maximum dispersion	m	0.77
Equilibrium hor. emittance	nm	23
Hor. emittance at extraction	nm	33
Momentum compaction		0.0057
Hor. betatron damping time	msec	7.26
Vertical betatron damping time	msec	7.36
Synchrotron damping time	msec	3.70
Equilibrium energy spread		6.2×10^{-4}
RF frequency	MHz	476
Harmonic number		81
RF peak voltage	MV	0.5
Bunch length	cm	0.48

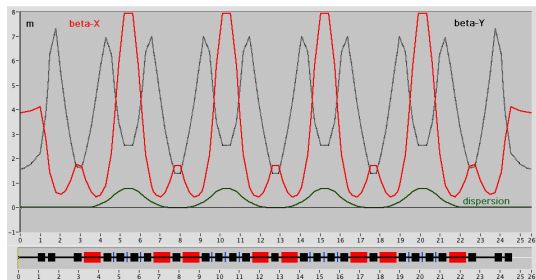

Figure 5: Optical functions of half damping ring. Dipoles are red, quadrupoles black, sextupoles blue.

Transfer lines to and from the Damping Ring

To make the transfer lines (TL), we have envisaged the use of as many PEP II magnets as possible. The maximum field of the PEP II dipoles is 0.93 T for a length of 0.45. The quadrupoles are 0.43 m long for a gradient of 9.5 T/m.

Being E1 and E2 respectively the TL from the 1-GeV linac to the DR and from the DR to the second linac for the electron beam. The TL's P1 and P2 are their equivalent for the positron beam. A layout of the four TL is given on Fig. 6. The injection (extraction) septa of the DR correspond to the first magnets on the left. The four TL must be achromatic. In the linac, the transfer matrix in the horizontal (vertical) plane for the electron beam is the one in the vertical (horizontal) plane for the positron beam. The vertical (horizontal) betatron functions at the beginning of E1 must then be equal to the ones horizontal (vertical) for P1. We have the same constraints at the end of E2 and P2. The bunch compressor is located at the end of E2 and P2 to minimize the energy spread of the beam after acceleration in the linac and optimize injection in the

main rings. The best compromise for the compression factor is ≈ 9 .

The bunch compressor consists in a 2.856-GHz 19.3-MV RF cavity, located in a 3.5 m long drift followed by a 13.1-m-long C-chicane. The chicane consists in two 1.35-m-long 0.83-T separators at its beginning and its end. Six other 0.83 T magnets are inserted in between. The parameters for the four TL are resumed in Table 2.

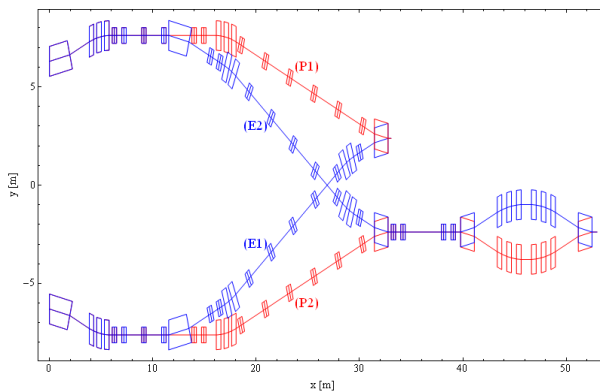

Figure 6: Layout of the transfer lines. Positron beams are red, electron beams blue.

Table 2: Transfer lines parameters

	Units	E1	E2	P1	P2
Total length	m	35.7	56.1	34.1	54.4
Dipole field	T	0.83	0.83	0.83	0.83
Max QP gradient	T/m	4.8	6.6	6.6	7.1
Max β_x	m	20.6	35.6	19.5	27.2
Min β_x	m	1.07	0.53	0.53	0.63
Max β_y	m	43.5	57.7	58.8	42.8
Min β_y	m	1.56	0.42	0.39	0.46
Max D_x	m	3.56	4.94	2.07	2.29
Min D_x	m	-3.6	-3.5	-2.9	-2.8

Main Rings Injection

Since we inject with colliding beams we want to keep the betatron oscillation of the injected beam as low as possible to avoid any perturbation to luminosity and detector backgrounds. The main rings configuration has non-zero dispersion at injection and an energy offset of the injected beam. This allows smaller oscillations of the injected beams at the interaction point, where dispersion is zero. From linear optics calculations the betatron oscillations of the injected beam are: $16\sigma_x$ for LER and $12\sigma_x$ for HER; this should provide enough safety margins also when beam-beam and nonlinear effects are taken into account.

REFERENCES

- [1] M.E. Biagini et al., The SuperB Accelerator Overview, these proceedings
- [2] J.E. Clendenin et al. The SLAC Polarized Electron Source, SLAC-PUB-9509, Oct. 2002.
- [3] G. Isoyama et al., Upgrade of the L-band Linac at ISIR Osaka University, Proceedings of APAC-2004, Gyeongju, Korea.
- [4] F. Poirier et al., Positron production and capture based on low energy electrons for SuperB, these proceedings.