

LIQUID HYDROGEN ABSORBER FOR MICE

S. Ishimoto, S. Suzuki, M. Yoshida, KEK, Tsukuba, Ibaraki, 305-0801 Japan
 M.A. Green, LBNL, Berkeley, CA 94720, USA
 Y. Kuno, Osaka Univ., Toyonaka, Osaka, 560-0043 Japan
 W. Lau, Oxford Univ., Oxford, OX1 3RH, UK

Abstract

Liquid hydrogen absorbers for the Muon Ionization Cooling Experiment (MICE) have been developed, and the first absorber has been tested at KEK. In the preliminary test at KEK we have successfully filled the absorber with ~2 liters of liquid hydrogen. The measured hydrogen condensation speed was 2.5 liters/day at 1.0 bar. No hydrogen leakage to vacuum was found between 300 K and 20 K.

The MICE experiment includes three AFC (absorber focusing coil) modules, each containing a 21 liter liquid hydrogen absorber made of aluminum. The AFC module has safety windows to separate its vacuum from that of neighboring modules. Liquid hydrogen is supplied from a cryocooler with cooling power 1.5 W at 4.2 K.

The first absorber will be assembled in the AFC module and installed in MICE at RAL.

INTRODUCTION

An important part of the MICE experiment is muon energy absorber. In an absorbing material, muons lose energy due to ionization loss. Hydrogen is the most suitable material, because of its large ionization loss and small probability of multiple scattering [1]-[6].

The AFC modules, each including a 21 liter liquid hydrogen absorber, are designed and under construction. The first absorber has been independently cooling-tested in a test cryostat at KEK. The purpose of this test is to

check the overall performance including hydrogen leakage and heat inputs to the absorber.

In MICE, hydrogen will be supplied from a metal-hydride hydrogen absorption system, and cooled by a Cryomech PT415 cryocooler with cooling power 1.5W at 4.2K. In the KEK test, a Sumitomo RDK-415D cryocooler with cooling power 1.5 W at 4.2K was used. Liquid hydrogen was supplied to the absorber from the bottom of a condenser attached to the second stage of the cryocooler. Evaporated hydrogen gas returned to the top of the condenser.

Hydrogen is explosive when mixed with oxygen or air. Safety is thus the main concern in absorber design. We introduced the following factors to enhance safety: (1) window design and testing to a safety factor of 4, (2) a double window system which allows for the bursting of at least one of the two windows, and (3) coverage of all vacuum chambers with argon gas to avoid air condensation on cold surfaces.

INSTRUMENTATION

Figure 1 shows the AFC module. The liquid hydrogen absorber was set at the center of the focusing superconducting (SC) magnet. The magnet bore diameter is 470 mm. The AFC module length along the beam is 844 mm. The main flange diameter is 1,514 mm. Double windows are used for safety. The space between these windows is vacuum pumped.

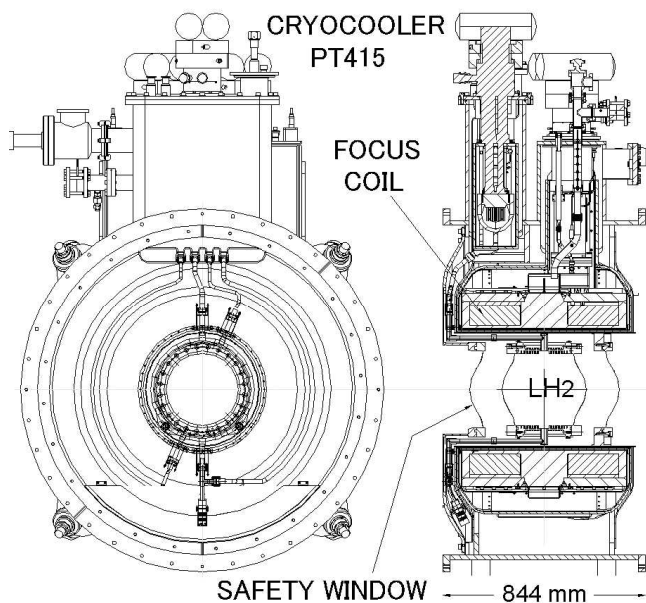

Figure 1: MICE AFC module with liquid hydrogen absorber.

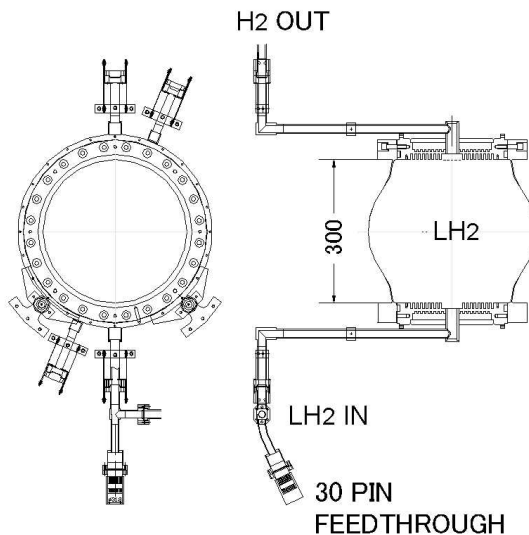

Figure 2: MICE liquid hydrogen absorber.

Figure 2 shows the liquid hydrogen absorber. It is made of aluminum, with 300 mm inner diameter and 21 liter volume. The aluminum windows are a double-radius bell shape with tapered thickness of 0.18 mm at center.

The liquid hydrogen absorber has an internal cooling channel with heat exchanger. The absorber was pre-cooled with liquid nitrogen via this cooling channel. This channel also makes it possible to cool directly using liquid helium. Four mini indium-seal flanges were used to connect aluminum pipes from the absorber and stainless steel pipes from the cryocooler.

Figure 3 is an inside view of the liquid hydrogen absorber. Two O-rings made from $\phi=1.5$ mm indium wire in grooves sealed the absorber body and windows. Also shown are the heat exchanger fins and 5 pairs of thermometers, LakeShore Cernox 1050-SD. The 5 Cernox thermometers were placed inside the absorber at 5 locations, and were monitored with a LakeShore 218S.

A pair of Cernox sensors monitored the liquid hydrogen level. One of these was operated with normal current as a thermometer, and the other was used in overcurrent mode as a level sensor. The difference of measured temperatures is small when these sensors are in liquid due to good cooling efficiency. On the other hand, it becomes larger when these sensors are in gas, with its worse cooling efficiency.

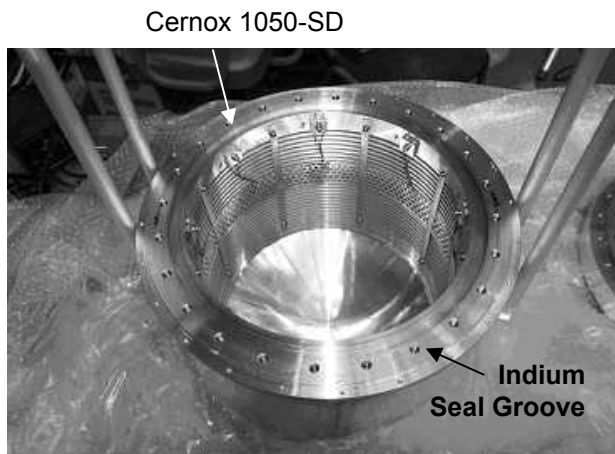

Figure 3: Inside view of liquid hydrogen absorber

These sensor-wires were extracted to vacuum at the middle of the liquid hydrogen inlet pipe using a 30 pin hermetic feedthrough as in Figure 4. The sensors are connected by 2 wires between sensors to the feedthrough, and by 4 wires after it.

Five additional Cernox thermometers were mounted on the hydrogen and liquid helium in/out lines and absorber body. These 5 thermometers were attached in the vacuum region.

To minimize heat input from the magnet bore, the liquid hydrogen absorber was mounted on glass-epoxy (G10) supports. To minimize radiative heat input from surrounding material, multilayer insulation (MLI) was wrapped around the entire absorber body and all pipes

and low-temperature parts. Figure 4 shows the liquid hydrogen absorber wrapped with MLI and its G10 supports. (In the figure, the 30 pin feedthrough and liquid hydrogen inlet pipe are outside the MLI.) The window surface was wrapped with one set of MLI, 5 aluminized Mylar sheets and 6 Nylon mesh spacers. Other parts were wrapped with 2–3 sets of MLI.

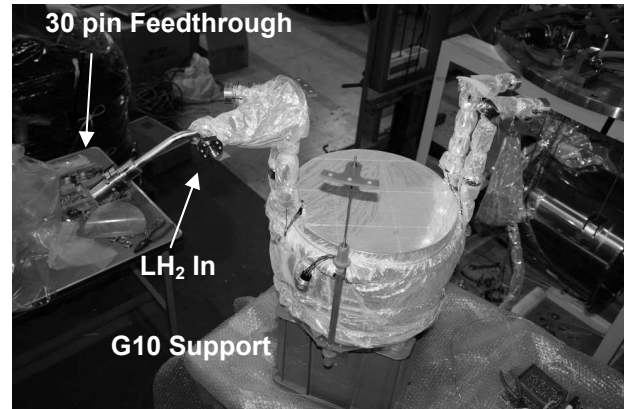

Figure 4: Photo of liquid hydrogen absorber wrapped with MLI, with G10 support attached.

COOLING TEST

The liquid hydrogen absorber development and cooling test were performed at KEK using a test cryostat shown in Figure 5. Test aluminum windows with simple radius and 1.5 mm thickness were used instead of the delicate actual windows. A stainless steel pipe of inner diameter 470 mm was used as a mock-up of the actual magnet bore.

Gaseous hydrogen was supplied from a 2 m³ tank, and condensed in a condenser attached to the Sumitomo RDK-415D G-M cryocooler.

Pressure, vacuum and thermometers were monitored by a Keithley 2700 data-logger and a LakeShore 218S. Data from these instruments were acquired with a GP-IB system and LabView software running on a personal computer.

TEST RESULTS

Cooling time results are presented in Figure 6. It takes about 3.5 days from 300 K to 80 K without liquid nitrogen pre-cooling, and 0.5 day from 80 K to 20 K.

Figure 7 shows the hydrogen tank pressure with 2 m³ volume. The liquid hydrogen filling speed into the absorber could be obtained from a gradient of the tank pressure. The liquid hydrogen filling speed at about atmospheric pressure was measured as ~2.5 liters/day.

After ~2.0 liters of liquid hydrogen had been transferred into the absorber, the cryocooler was turned off and the cooling test stopped. The 2 liter limit of liquid hydrogen volume is due to safety requirements at the KEK test area.

During the cooling test, the vacuum level was monitored as $\sim 10^{-7}$ mbar when liquid hydrogen was in

the absorber. We observed no evidence of hydrogen leak to vacuum or air.

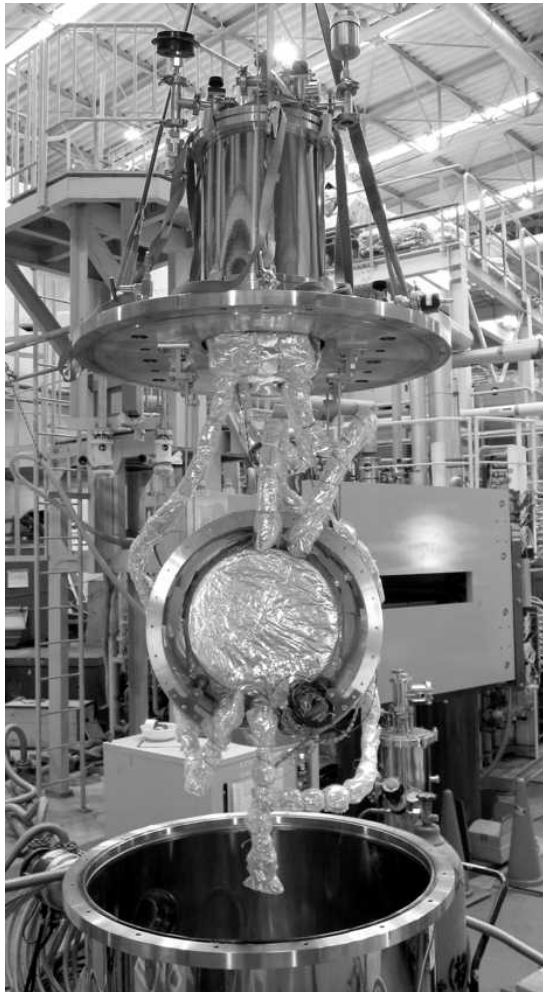

Figure 5: Liquid hydrogen absorber and test cryostat. The large stainless steel pipe outside absorber is a dummy of SC magnet bore.

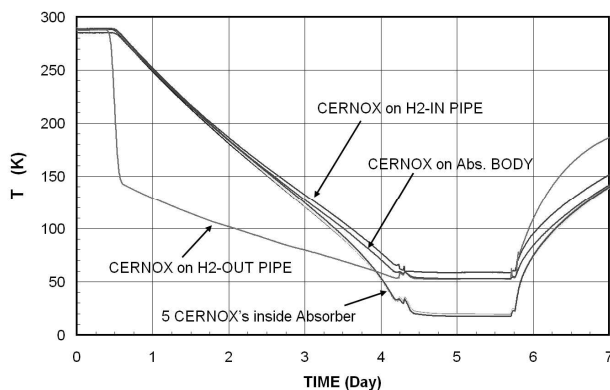

Figure 6: Cooling time of liquid hydrogen absorber. Eight Cernox thermometers were measured by LakeShore 218S.

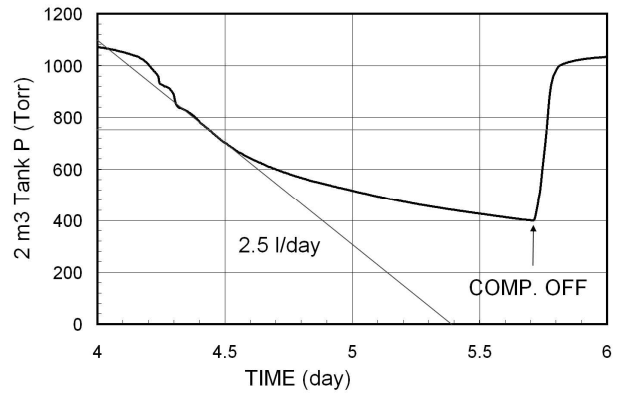

Figure 7: The hydrogen 2 m³ tank pressure and filling speed of liquid hydrogen in absorber.

CONCLUSION

The first MICE liquid hydrogen absorber was fabricated and successfully cooling-tested at KEK. The condensation speed was measured as 2.5 liters/day at 1.0 bar. We observed no evidence of hydrogen leak.

The pre-cooling time without liquid nitrogen was 4 days. It was estimated as about 0.5 day with liquid nitrogen pre-cooling. The filling time of the 21 liter absorber was estimated as ~ 8 days. Either better heat insulation or a higher cooling power unit such as the Cryomech PT415 will improve the filling time.

The first absorber will be shipped to RAL. The second and third absorbers will then be assembled and tested at KEK. They will be integrated into the AFC modules and used for the MICE experiment at RAL in the near future.

REFERENCES

- [1] S. Ishimoto *et al.*, Nucl. Instr. and Meth. **A 503** (2003) 392–395.
- [2] D. M. Kaplan *et al.*, Nucl. Instr. and Meth. **A 503** (2003) 396–400.
- [3] M. A. C. Cummings *et al.*, J. Phys. **G 29** (2003) 1689–1692.
- [4] D. E. Baynham *et al.*, Advances in Cryogenics **51**, pp. 1076–1083, AIP Press, Melville, NY (2005).
- [5] W. Lau *et al.*, Advances in Cryogenics **51**, pp. 1084–1091, AIP Press, Melville, NY (2005).
- [6] M. A. Green *et al.*, Proceedings of the 2005 Particle Accelerator Conference, p. 1601.