

PRELIMINARY DESIGN OF THE AEGIS TEST FACILITY

Luca Dassa, University of Brescia, Brescia, Italy
 Diego Perini, CERN, Geneva, Switzerland
 Danilo Cambiaghi, University of Brescia, Brescia, Italy

Abstract

The AEGIS experiment is expected to be installed at the CERN Antiproton Decelerator in a very close future, since the main goal of the AEGIS experiment is the measurement of gravity impact on antihydrogen, which will be produced on the purpose.

Antihydrogen production implies very challenging environmental conditions: at the heart of the AEGIS facility 50 mK temperature, $1e-12$ mbar pressure and a 1 T magnetic field are required. Interfacing extreme cryogenics with ultra high vacuum will affect very strongly the design of the whole facility, requiring a very careful mechanical design.

This paper presents an overview of the actual design of the AEGIS experimental facility, paying special care to mechanical aspects. Each subsystem of the facility – ranging from the positron source to the recombination region and the measurement region – will be shortly described. The ultra cold region, which is the most critical with respect to the antihydrogen formation, will be dealt in detail. The assembly procedures will be considered too, as they are expected to be critical to make the set-up phase easier, as well as to make possible any future improvement of the facility itself.

INTRODUCTION

One of the most important troubles of the modern physics is the understanding of the role of the dark matter and the dark energy in the universe. A new theory replaces the role of the dark matter with the anti-matter. In order to increase the knowledge about anti-matter, the Aegis experiment intends to perform a direct measurement of the Earth's gravitational acceleration g on pulse beam of antihydrogen by means of a classical Moiré interferometer [1]. The antiproton will be provided at CERN by the Antiproton Decelerator (AD), where the

Aegis facility will be installed. The common background of the Aegis collaboration is the Athena facility [2], the first experiment to produce, in 2002, a large amount of antihydrogens. The new experimental facility, composed and designed by different groups, requires particular care into the integration of different components, since the requirements in term of pressure and temperature at the heart of the facility are very severe: $1e-12$ mbar and 50 mK in 1 T magnetic field. Due to the innovative aspects of this facility all the experts involved into the design are moving almost at the border of their knowledge.

The integration overseers and the mechanical designers have to fit different aspects in a single “machine” never designed before. The aim of this paper is to show the original solutions suggested in order to compose a complex device able to satisfy all the different requirements.

THE AEGIS FACILITY

As shown in figure 1 the Aegis facility can be ideally divided in different sections: AD transfer line (1), positron source + positron accumulator + positron transfer line (2), main cryostat (3), deflectometer (4).

The AD transfer line, designed by the CERN AD technicians, will provide the focus point in a proper region of the experiment. The package “positron source + positron accumulator + positron transfer line” is partially designed by the Aegis collaboration and partially bought. Positron source and positron accumulator are not very critical with respect to the integration point of view since they are in series and placed above the AD transfer line on proper supports. Otherwise the positron transfer line requires special care since it has different tasks: transfer the positrons from the positron source axis to the experiment main axis, contain all the pumps needed to reach the UHV pressure into the Aegis main vacuum

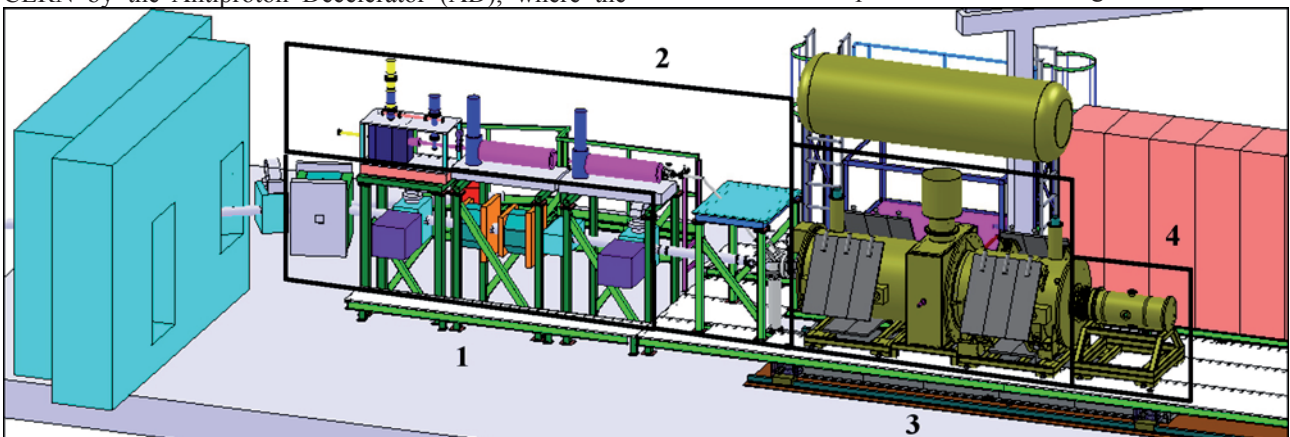

Figure 1: Aegis Facility into the Antiproton Decelerator at CERN.

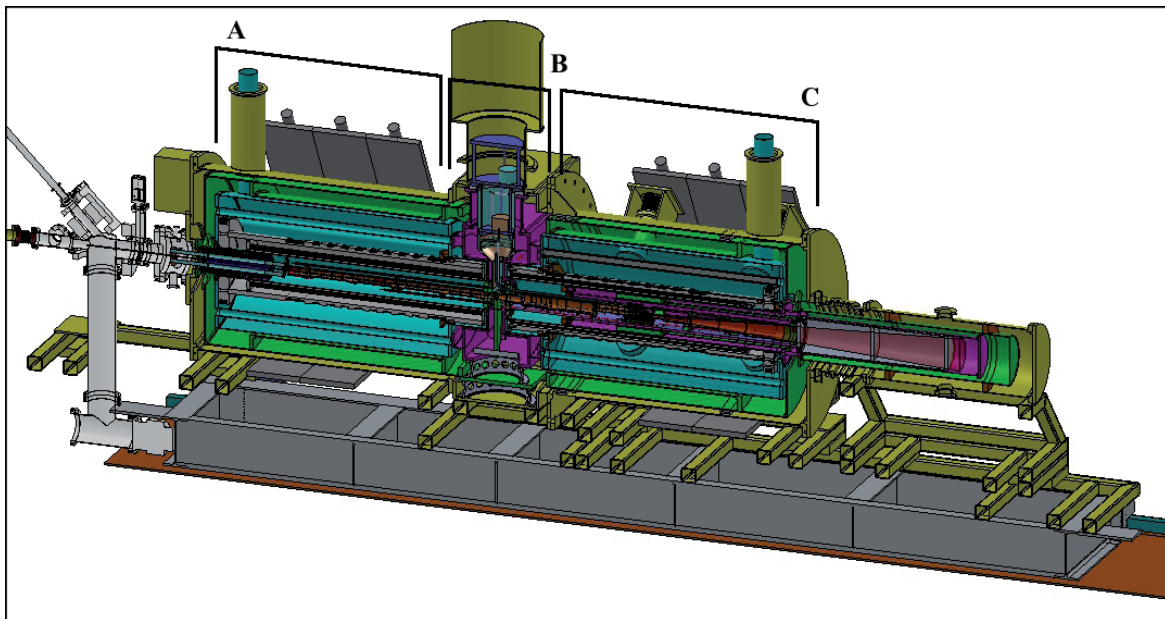

Figure 2: Section of the Aegis main cryostat

chamber, contain instrumentation needed to monitor the particles behaviour. In any case the volume allocated for the positron transfer line is well defined and the interfaces with other subsystems are clear.

The most complex region of the Aegis experiment is the main cryostat, where, in order to generate the Hbar, there are the most strong requirements in term of pressure and temperature. In this region, different groups are involved and the coordination is strongly required: cryogenic requirements, magnetic requirements, vacuum requirements are to be guaranteed in the middle of a collaboration of different groups: the experts of the CERN Cryogenics laboratory (TE-CRG-CI group), the CERN magnet designer, the traps designers, the laser experts and the target experts. The main requirements are: easy opening procedure; unique internal UHV chamber crossing the cryostat; unique external HV chamber for insulating purposes; sub-components of the main cryostat (A, B and C in figure 2) self standing when the main cryostat is open; sub-cryostats A (5 Tesla magnet) and C (1 Tesla magnet) composed by outer vacuum vessel, nitrogen vessel, helium vessel; design not over-constrained when the entire cryostat is closed, only one fixed point with respect to the thermal shrinkage;

possibility to align the overall device with respect to the AD beam axis.

A big chariot (grey in figure 2 and 3) supports the main cryostat and the deflectometer. It can be moved in the direction of the main axis when it is necessary to open the cryostat and have access to the traps (see figure 3). The same big chariot has 4 degrees of freedom (thanks to jacks similar to LHC dipoles [3]) in order to adjust to the AD beam axis.

The fix point for the main cryostat is the region between the two sub-cryostats, named B in figure 2. This region is composed by an outer vessel, a nitrogen shield and a sector of the inner UHV chamber. A fiber glass foot, fixed to the main chariot, connects in series the three previous components. The two sets of traps (one for 5 Tesla traps and the other one for 1 Tesla traps) are fixed to the region B such as a cantilever beam.

Each sub-cryostats is self standing: its frame is the outer vacuum vessel (yellow in figures 2 and 3); the nitrogen vessel is directly supported by the outer vessel with 3 fibre glass feet, the helium vessel is supported by the outer vessel with 8 Kevlar wires (4 on the front side and 4 on the rear side, in the shape of a cross), with selectable length. Since the Kevlar wires have an high

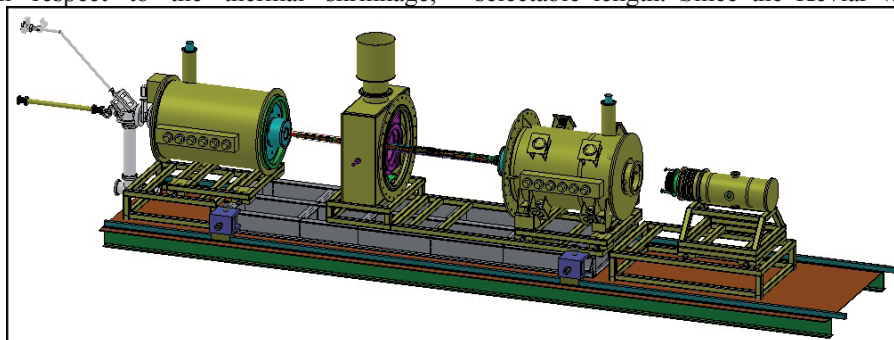

Figure 3: assembly of the Aegis facility

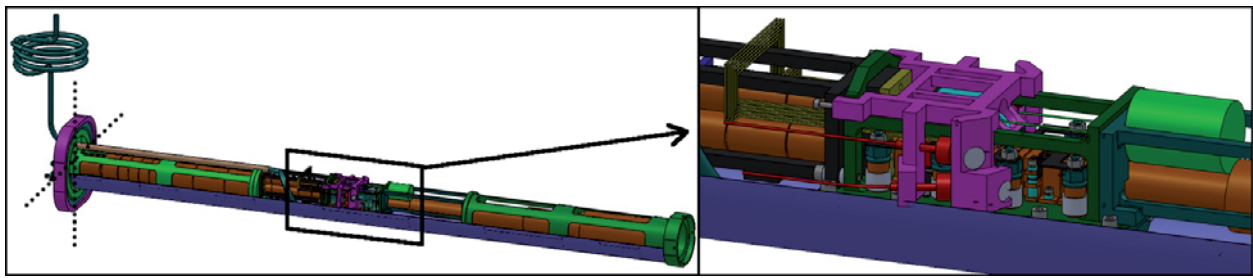

Figure 4: 1 Tesla traps

strength, it is possible to use small cross section in order to support high load and decrease in the same time the heat transfer. Each outer vessel can be moved with respect to the main chariot by way of 4 jacks, similar to the LHC jacks but smaller.

In order to assembly the cryostat, the big chariot (with region B, rigidly linked to it) is aligned with respect to the AD beam axis. Each sub-cryostat is moved on rails in order to reach the flanges of the region B. In fact each sub-cryostat is connected to the region B by way of two flanges, the first one for inner UHV chamber, the outer one - on the outer vacuum vessel - in order to create the chamber for insulating purposes. In order to fit both flanges, it is necessary to act on the outer vessel jacks and on the Kevlar wires on each sub-cryostat. Once the main cryostat is closed, it is possible to release some Kevlar wires in order to reduce the over-constraints.

The deflectometer, the instrument able to measure the effect of the gravity on the Hbar, is autonomously supported and connected to the main cryostat by way of two concentric flanges in order to close the two vacuum chambers. Proper bellows will avoid an over-constrained design. The deflectometer doesn't have a dedicated active cooling but it is cooled directly by the nitrogen vessel and the helium vessel of the closest sub-cryostat.

THE 1 TESLA TRAPS

Into the UHV chamber crossing the main cryostat, some trap packages will be installed in order to handle the particles. If the 5 Tesla packages don't have special requirements, the 1 Tesla set of traps requires an high coordination effort. This is the heart of the Aegis facility where Hbar is generated: in a volume with small cross-section (142 mm in diameter) it is necessary to place the mixing chamber of the dilution refrigerator, the electrodes for handling the particles, the target for transforming the positrons in positronium, the laser beams for exciting the positronium before the collision with antiprotons. Each component is studied by a different scientist and the coordination has to compose the different requirements. In addition the scientists require to move the 1 Tesla package around two axis (± 1 mrad) with respect to the axis of the main magnetic field, during standard functioning of the facility (see the dotted lines in figure 4).

The actual solution is shown in figure 4. The two laser beams are transferred into the UHV chamber by way of optical fibres; each beam will be bended by a mirror in

order to reach the positronium. The target, the two mirrors and the fibre heads will be supported together and thermalized at 1.5 K. The set of the ultracold electrodes (50 mK) will be placed directly on the cover of the mixing chamber and the cooling will be performed by way of proper rods [4] in development at the CERN CryoLab. In addition to pay attention to materials and the thermal shrinkage of the component, it is necessary to place 100 cables around the traps and the pipe for mixing chamber helium supply. An active cooling shield around the traps is foreseen in order to have a stable temperature of 1.5 K. In order to displace the traps, two solutions are under evaluation: the use of Kevlar wires actuated from outside and the use of piezoelectric actuators installed directly on the helium vessel. The main issue is the necessity to move with a very small displacement an heavy package (about 40 kg) at 1.5 K and with a pressure of 1e-12 mbar.

CONCLUSIONS

This paper presents a short overview of the actual status of the Aegis facility. It is clear that the coordination plays a key role and cannot be underestimated in order to progress with detailed design. Future publications will detail different aspects of the Aegis facility.

REFERENCES

- [1] Aegis collaboration, "Proposal for the AEGIS experiment at the CERN Antiproton Decelerator (Antimatter Experiment: Gravity, Interferometry, Spectroscopy)", June 8, 2007
- [2] Athena collaboration, "The ATHENA antyhydrogen apparatus", Nuclear Instruments and Methods in Physics Research A 518 (2004) 679-711
- [3] J. Dwivedi, A. Kumar, S.G. Goswami, V. Madhumurthy, V. Parma, H.C. Soni, "The alignment jacks of the LHC cryomagnets", LHC Project Report 725
- [4] Eisel T. et al, "Cooling of electrically insulated electrodes down to 0.1K.", Proceedings of the twenty third Cryogenic Engineering Conference, Poland; 2010 (submitted for publication)