

TECHNIQUES FOR OBSERVATION OF BEAM DYNAMICS IN THE PRESENCE OF AN ELECTRON CLOUD*

M. G. Billing, G. Dugan, R. Meller, M. Palmer, M. Rendina, N. Rider, J. Sikora, C. Strohman, CLASSE, Cornell University, Ithaca, NY 14853

R.L. Holtzapple, California Polytechnic State University, San Luis Obispo, CA 93407, USA

Abstract

During the last several years the Cornell Electron Storage Ring (CESR) has been studying the effects of electron clouds on stored beams in order to understand their impact on future linear-collider damping ring designs. One of the important issues is the way that the electron cloud alters the dynamics of bunches within a train. Techniques for observing the dynamical effects of beams interacting with the electron cloud have been developed. These methods will be discussed and examples of measurements will be presented.

EXPERIMENTAL PROGRAM

The CESR-Test Accelerator (CESR-TA) project[1] makes use of the CESR storage ring for two major experimental focuses. The first is developing optics measurement and correction techniques to produce low emittance beams for future linear collider damping rings. The scope includes understanding and correcting the storage ring's linear optics, coupling and vertical dispersion to produce small transverse beam sizes and for low emittance tuning (LET.) The second is to study the properties of electron clouds produced by positron and electron beams in trains of various lengths and for different bunch spacings. These efforts include observations, which are either to study the cloud buildup from primary and secondary electrons generated through the trains (such as tune shift of bunches) or to study the spatial distribution of clouds for different types of vacuum chambers' surfaces using retarding field analyzers (RFAs), TE-wave measurements and shielded pickups.

TECHNIQUES FOR LET

In order to produce low emittance beams, it is necessary to control the storage ring optics accurately. The linear optics are routinely measured via the betatron phase measurement system, composed of a tune tracker system and the CESR beam position monitor (CBPM) modules[2]. Figure 1A shows a block diagram of the Tune Tracker System, which has a tune receiver that processes signals from a stripline beam position monitor (BPM.) This is connected to the tune tracker chassis that phase locks one of the betatron tunes via a power amplifier driving a shaker (deflecting) magnet. The phase locked loop's output reference sinusoidal signal has its phase sampled at each of CESR's turns in the BPM clock

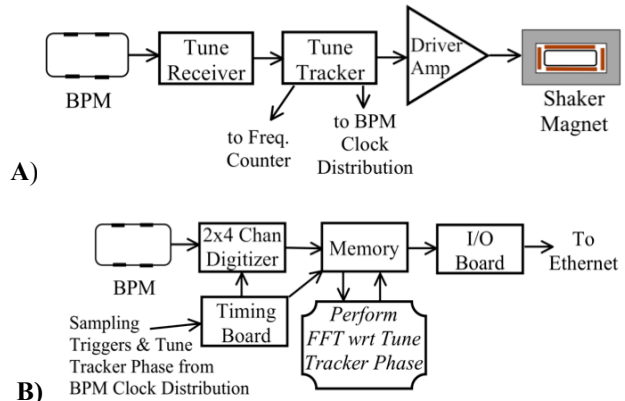

Figure 1. Block diagrams of A) the Tune Tracker for phase locking betatron tunes and B) a CBPM module while the FFT is being applied to turn-by-turn data.

card in the timing system. The digitized phase's value is encoded on a turn-by-turn basis into the timing clock distributed to each of the CBPM modules. A CBPM module (block diagram in figure 1B) digitizes the beam's signal from each button for 40,000 turns and then perform a fast Fourier transform (FFT) of it with respect to the tune tracker phase, ultimately resulting in the horizontal and vertical components at the betatron tune. Both horizontal and vertical eigen modes are measured simultaneously yielding betatron phase advances and one coupling matrix element at each BPM location. With the independent powering of the CESR quadrupoles, any errors compared with the design optics may be corrected to less than $\pm 0.1^\circ$ in phase. A second technique is being studied for optics corrections using a fully-coupled model independent analysis (MIA) of turn-by-turn trajectories with the beam being driven by the tune trackers first in one eigen-mode and then the other.[3] This method uses the amplitude of the betatron oscillation in addition to the phase; first results give betas consistent within a few percent between the two methods.

To produce the smallest vertical emittances, the vertical dispersion must be kept at the lowest possible levels. Dispersion measurements are made conventionally using the orbit displacement from a change of the RF cavity frequency. A new technique has also been developed and is now employed routinely using a tune tracker exciting the RF phase of one of the accelerator cavities at the synchrotron tune and measuring the turn-by-turn trajectory of the beam.[4] The latter method requires only a small perturbation of the beam and is insensitive to any change in the orbit during the measurement.

* Work supported by NSF & DOE contracts and an NSF Career Grant.

During LET studies of the beams different vertical beam size monitors are available. One, called the xBSM, uses x-rays from one of the CHESS beam lines imaged via a pin-hole, a Fresnel zone plate or a coded aperture onto a 32-channel linear x-ray detector read out with a pre-amplifier in front of a bunch-by-bunch and turn-by-turn data acquisition system.[5] In addition to providing beam size information for LET this detector system is part of a tune plane scanning system.

ELECTRON CLOUD OBSERVATIONS

Electron clouds generated by either positron or electron beams in trains of bunches with spacings as low as 4 nsec are studied with a variety of techniques. RFAs are installed in a number of different vacuum chamber environments, such as bending magnets, superconducting wigglers, a quadrupole, allowing the examination of different geometries, vacuum chamber surface materials or preparations.[6] RFAs collect electrons via biased time-averaged collectors, viewing the cloud through sets of holes in the chamber's wall. These provide information about the spatial distribution of the electron clouds.

Another technique for measuring the local cloud density, called the TE-wave method, utilizes microwaves near the beam pipe's cutoff frequency detected on BPM buttons.[7] This method is employed above the cutoff frequency to measure the electron cloud's modulation of the TE-mode's transmission along the vacuum chamber between two sets of buttons or below the cutoff frequency to measure the local cloud density. The observations from TE-waves give average cloud densities and the FFT of the cloud's time development.

Within the last year shielded button detectors have been added at a few vacuum chamber locations to give more information about the time evolution of the electron clouds. These are button BPM structures, which are located outside of arrays of holes through the vacuum chamber walls. The signals arriving from the buttons are observed on an oscilloscope when different bias voltages are applied to the BPM electrode. Figure 2 shows a set of oscilloscope signals taken with pairs of 3 mA positron bunches with different spacings in the aluminum vacuum chamber at 15W. There is a fast bipolar signal from the bunch's electromagnetic (E-M) fields when each bunch passes; following this is the cloud's signal from the electrons, which pass through the holes in the chamber wall. Notice that the electron cloud signal is significantly enhanced by the passage of the second bunch as its E-M fields accelerate electrons from the cloud toward the shielded button. As the second bunch is delayed, the signal from the cloud's response samples the time evolution of the cloud from the first bunch. The shape of the signal in the shielded button carries information about the flight time of the electrons in the cloud to the detector.

The global effect of the electron clouds in all of the CESR vacuum chambers has been studied via coherent tune shift measurements for the bunches within a train of positrons or electrons and by witness bunches following

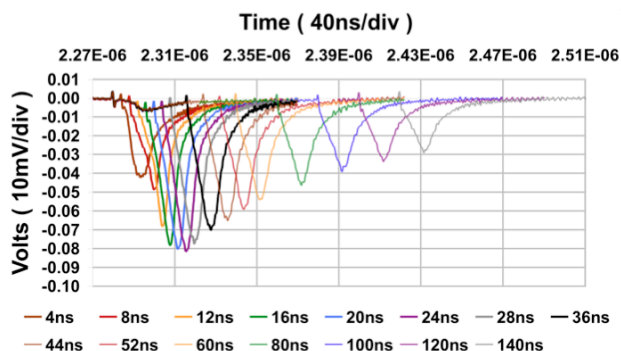

Figure 2. Response signals from the electron cloud generated by the passage of one or two positron bunches with the second bunch at different delays.

the train. The capability to store either beam permits some separation of electron cloud effects from wake-field effects. For coherent tune observations several methods can be used to excite the bunches. The method most commonly employed is to “ping the beam”, i.e. to deflect all of the bunches in the train in a single turn with pulsed ferrite steering magnets, first in one plane and then the other. A second method is being developed, which begins with a sine-wave generator that has its frequency swept across the range of the bunches' tunes. Its signal is connected to the external modulator input for the 14 nsec feedback system. This allows the excitation of individual bunches along the train by combining this external modulation signal with the feedback system's output to drive the power amplifier for the stripline feedback kicker. Although this gated shaking method requires more observations to study all of the bunches within a train, it has the advantage over the “pinging” method of reducing the excitation of the electron cloud by preceding bunches, which drive the response of the succeeding bunches within the train. Initial results of the study of the second excitation method look promising.

The observations of the tunes of the bunches within the train or for witness bunches after the train have been performed a few different ways. The most common method is to simultaneously take turn-by-turn data for all bunches with one or more of the CBPM modules while the beam is being excited by either the horizontal or vertical pinger.[8] This measurement makes use of the CBPM module's capabilities of recording turn-by-turn positions for all bunches (with the bunch spacings most often selected for study being 14 nsec and 4 nsec, although other multiples of 2 nsec have also been investigated.) An FFT of the damped oscillation for each bunch from this data yields its tune, ultimately giving the tune shift that occurs through the train.

Two alternate methods for tune shift observations have been tested with limited success. One method examined signals from the transverse dipole mode feedback system for 4 nsec-spaced bunches produced by Dimtel Inc.[9] When the monitor signal gate is set for a particular bunch with sufficiently high feedback gain and optimized feedback phase, a notch develops in the coherent

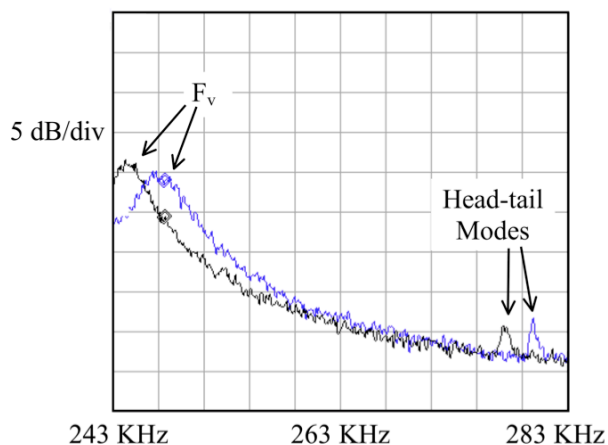

Figure 3. Spectra of the last bunch in a 45 bunch-long 1.3 mA positron train, spaced by 14 nsec. The vertical dipole modes are labeled F_v , while the head-tail modes are the left-hand peaks. Blue trace is before shifting the vertical tune; black trace is after shifting the tune.

spectrum at the frequency, which was at the bunch's spectral peak without feedback. The notch occurs because at a high gain, any energy present in the feedback system's input signal in the band of frequencies, which resonantly excites the bunch's motion, will be preferentially absorbed from the damping of the bunch. Although this method is most promising for detecting tunes of bunches with small excitations, it has been difficult to maintain the necessary phase precision throughout the train when there is a large tune shift. The second method employs signals routed through CESR's original relay BPM system to one of the six processors, where an adjustable-delay 6 nsec wide gate is applied before peak rectifying the button signal with a diode stretcher. The BPM processor sends the stretched signal to a spectrum analyzer in the control room for analysis.

The tune excitation and tune shift measurement methods described above produce information about the beam's stability, i.e. the bunch-by-bunch damping rates of the coherent dipole oscillations. From the pinger or gated shaking excitation observed by the turn-by-turn CBPM measurements, this is determined from the exponential decay of each bunch's oscillation amplitude. From the relay BPM's signal gated on a particular bunch, the damping rates are visible on a spectrum analyzer tuned to the oscillation frequency and displaying the oscillation amplitude vs. time. The damping rates may be determined from the 4 nsec or 14 nsec feedback system, when either is in operation, by turning off or reversing the sign of the feedback gain for individual bunches producing grow-damp measurements. Damping rate measurements are particularly useful for quantifying dynamical effects, which alter the stability of a bunch's oscillations at currents below the onset of unstable motion occurring at the instability threshold current.

Another class of observations in CESR focuses on the tune shift and stability of transverse head-tail modes. Three methods have been successful for observing this

class of oscillations. The first two techniques observe the signal from either the tune receiver for the ensemble of bunches or from the relay BPM system gated on a particular bunch, when a head-tail mode's self-excited oscillation amplitude grows above a threshold level. The latter of these two methods permits the measurement of the tune shift and self-excited amplitude along the train of bunches. The third technique observes the head-tail modes with the relay BPM system gated on a particular bunch when they are excited using the combination of the single-betatron wavelength pulsed injection bump, which leaves a small transient energy oscillation, preceding the triggering of a pinger magnet. This last method allows the measurement of head-tail modes before they become self-excited. As an example, figure 3 displays the spectra from the last bunch in a 45 bunch-long, 14 nsec-spaced train of positron bunches, before and after shifting the vertical tune for a 2 GeV beam. The vertical dipole mode is the large peak to the left side of the spectra; the head-tail mode is shifted above the vertical tune by a little more than the synchrotron oscillation frequency (25.9 KHz.)

CONCLUSIONS

A number of different methods for observing the effects of electron clouds in storage rings have been presented. In many cases there have been different methods for observing the same effect and, although not all of these are used in the routine data collection, they are powerful tools for cross-checking the observations.

ACKNOWLEDGEMENTS

The authors would especially like to thank S. De Santis for the analysis of the shielded button data.

REFERENCES

- [1] M. A. Palmer, "Electron Cloud at Low Emittance in CEsrTA", TUYMH02, these proceedings.
- [2] M. A. Palmer, et al, "CESR Beam Position Monitor System Upgrade for CEsrTA and CHESS Operations", MOPE089, these proceedings.
- [3] M. Billing, et al, "Model Independent Analysis with Coupled Beam Motion", PAC2009 Proceedings.
- [4] J. P. Shanks, et al, "CesrTA Low Emittance Tuning", THPE046, these proceedings.
- [5] J. Alexander, et al, "CESR-ta x-Ray Beam Size Monitor Operation", MOPE090, these proceedings.
- [6] J. Calvey, et al, "CesrTA Retarding Field Analyzer Measurements in Drifts, Dipoles, Quadrupoles and Wigglers", TUPD023, these proceedings.
- [7] S. De Santis, et al, "TE Wave Measurements of the Electron Cloud in the Cesr-TA Synchrotron Ring", MOPE088, these proceedings.
- [8] J. A. Crittenden, et al, "Progress in Studies of Electron-cloud-induced Optics Distortions at CesrTA", TUPD024, these proceedings.
- [9] Dimtel Inc., www.dimtel.com.