

## OPERATION OF THE PEFP 20MEV PROTON LINAC AT KAERI\*

Hyeok-Jung Kwon<sup>#</sup>, Yong-Sub Cho, Han-Sung Kim, Kyeong-Tae Seol, Dae-Il Kim, Ji-Ho Jang, In-Seok Hong, Young-Gi Song, Eun-Mi An, Kyung-Jean Min, Sang-Pil Yun, Bum-Sik Park  
PEFP, KAERI, Daejeon 305-353, Korea

### Abstract

The 20MeV proton accelerator has been operating since 2007 when it got an operational license at Korea Atomic Energy Research Institute (KAERI) by Proton Engineering Frontier Project (PEFP). Beam property such as an emittance was measured at the low energy beam transport (LEBT) to characterize the beam into the RFQ. In addition, several parts were modified to test the adaptability of those which would be used for the 100MeV linac. The modulator for the 100MeV linac was installed and tested in the 20MeV linac test bench. In addition, low level RF (LLRF) system was modified in the overall configuration and the operator interface (OPI) with EPICS. In this paper, the beam property measurement results and the modification of the linac are presented.

### INTRODUCTION

A 100MeV, 20mA proton accelerator is developed by PEFP. It will be installed at Gyeong-Ju site at 2012 [1]. As a front end part of the 100MeV accelerator, a 20MeV linac has been installed and operating at KAERI site. The operation goals of the 20MeV linac at KAERI site are as follows.

- It supply beam to users
- It is used for the machine study
- It is used for the test bench of the 100MeV machine components

The 20MeV linac got an operation license at 2007 and has supplied beam to 150 samples per year in average. In addition to the beam supply to users, the beam properties and machine performance have been studied to characterize the machine and setup the commissioning plan of the 100MeV accelerator. Also, the 100MeV machine components have been tested at 20MeV linac test bench to check its performance before they would be used for the 100MeV machine.

### LEBT EMITTANCE MEASUREMENT

The beam emittance of the LEBT was measured to study the beam matching into the RFQ. The LEBT consists of two solenoid magnets and two steering magnets [2]. An Allison type emittance scanner was used for the measurement, which was installed between two solenoid magnets. The design parameters of the emittance scanner are shown in Table 1. The design normalized rms emittance of the linac was  $0.2 \pi \text{ mm mrad}$ . The pulsed beam from the ion source was achieved by the semiconductor switch located at the beam extraction high voltage power supply. The beam pulse width was 2ms and

the measurement results showed that the beam distribution did not reach the steady state condition as shown in Fig. 1 because of the finite neutralization time. The beam emittance decreased as time went by. The dependency of the emittance on the LEBT gas pressure was measured to check the neutralization effect as shown in Fig. 2. The results showed that the emittance also decreased as the pressure increased. The measured unnormalized rms emittance was  $33 \pi \text{ mm mrad}$ , which was larger than the design value. One of the reasons for the large value was attributed to the misalignment of the extraction electrode and the 1<sup>st</sup> solenoid. We are going to check the emittance after we confirm the alignment of the LEBT component.

Table 1: Design Parameters of the Emittance Scanner

Parameters	Value
Chamber length	65mm
Electrode length	57mm
Plate margin	4mm
Slit width	0.1mm
Beam voltage	50keV
Gap distance	2.5mm
Maximum voltage	600V
Maximum analyzable angle	68.5mrad
Mechanical angular resolution	1.5mrad
Maximum beam radius	60mm

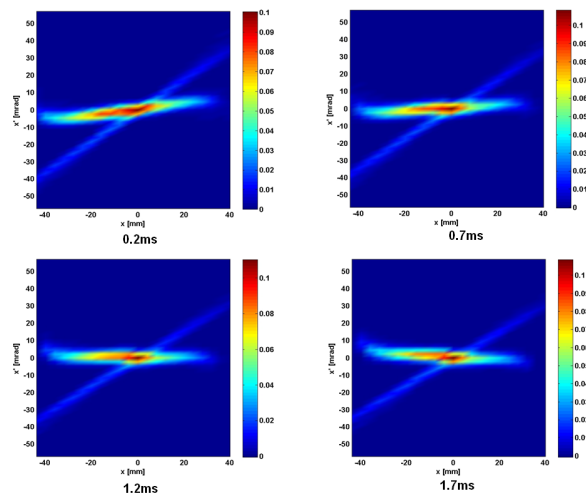

Figure 1: Phase space distribution of the beam from the LEBT at selected time

\* This work is supported by MEST of the Korean government

<sup>#</sup>hjkwon@kaeri.re.kr

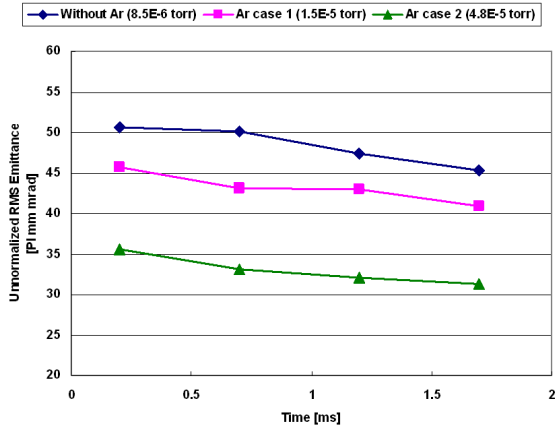

Figure 2: LEBT emittance depending on the LEBT pressure and time

### MACHINE COMPONENT PERFORMANCE TEST

Several components were modified and tested by using 20MeV linac not only for the upgrade of the 20MeV linac itself but also for the test of the 100MeV accelerator components.

#### Modulator

The modulator for the 100MeV accelerator was installed to drive the 20MeV linac. The purpose of the test was to test the modulator in the real system in advance before it would be installed for the 100MeV accelerator at Gyeong-Ju site. The specifications of the modulator are shown in Table 2.

Table 2: Specifications of the Modulator

Parameters	Value
Input voltage	3300Vac
Output voltage	-105kV
Output current	50A
Output peak power	5.8MW
Output average power	520kW @ 9% duty
Efficiency	> 92%
Pulse width / repetition rate	1.5ms / 60Hz
Flat top voltage regulation / droop	1% / 1%
Arc energy	< 20J

It used high frequency switching method by using Insulated Gate Bipolar Transistor (IGBT), which topology was used for the SNS modulator originally. There were two klystrons in the 20MeV linac and one modulator was used to drive the two klystrons simultaneously. The klystron (TH2089F, THALES) for 20MeV linac has a triode type electron gun. Therefore, modulating anode voltage should be supplied. Voltage dividing resistors

were used to supply the modulating anode voltage. In addition, capacitors were installed in parallel with the resistors to reduce the voltage rising time. The initial operation parameters of the modulator were 2.4MW peak power with 1ms pulse width and 4Hz repetition rate. The initial test results such as voltage and current profile of the modulator and the long term voltage stability are shown in Fig. 3, Fig. 4 respectively. The difference of the current profile of the two klystrons (Ch3, Ch4 in Fig. 3) was mainly due to the difference of the high voltage line inductance. The voltage droop was 1.8%. In fact, the voltage droop at full peak power was 3%. We are going to reduce the droop within 1% by controlling the IGBT switching pulse width or frequency. The voltage decreased about 0.8% and the fluctuation was less than 0.2% in standard deviation during 8 hours operation as shown in Fig. 4. The reduced average power was considered to be the reason of the voltage decrease of the long term operation. The average power would be increased after the modulating anode voltage dividing system was modified and the overall control system was upgraded.

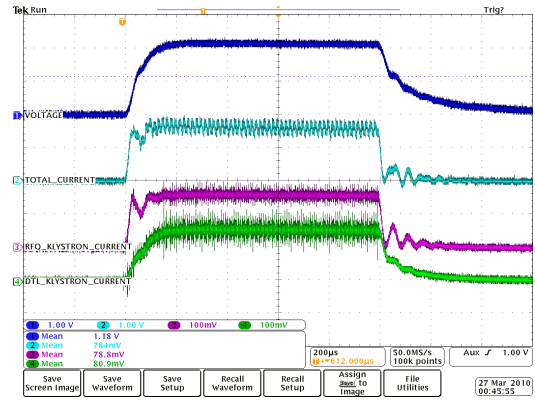

Figure 3: Modulator voltage and current pulse profile

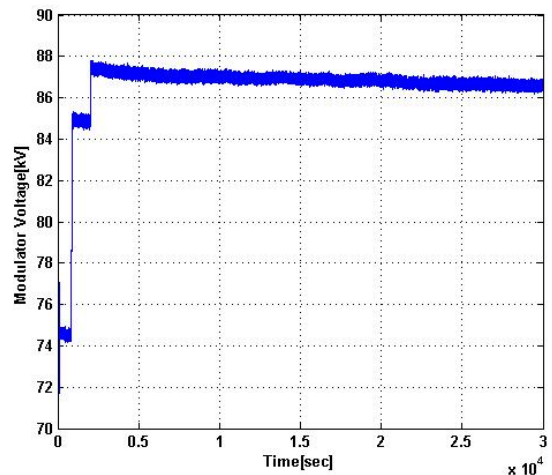

Figure 4: Voltage stability during initial operation

### Low Level RF System

The low level RF system of the 20MeV linac was modified. It adopted new control board and new EPICS operator interface (OPI).

A commercial multi-channel, high-speed data converter (Pentek 7142) was adopted as a new control board for the digital LLRF system. The specifications of the board are as follows.

- ADC: 125MHz, 14bits, 4Ch.
- DAC: 320MHz, 16bits, 1Ch.
- FPGA: Xilinx Virtex4 XC4VSX55
- Memory: DDR2 SDRAM (64M×32)
- Clock: External (1to 300MHz), internal (125MHz)
- Gate: Internal or external

The main characteristic of the new board was its capability to produce the synchronized phase IF signal at every trigger. Therefore, the IQ modulator installed at the analogue box and other auxiliary components for the IQ modulator could be eliminated. The block diagram of the modified LLRF system is shown in Fig. 5. We are going to use a LO (300MHz) as a reference signal and down convert the RF signal from the cavity or up convert signal from the board using the same reference signal. The analogue system was also modified to accommodate the IF signal directly from the control board. An EPICS control system based on the VME was newly developed and described more precisely elsewhere [3].

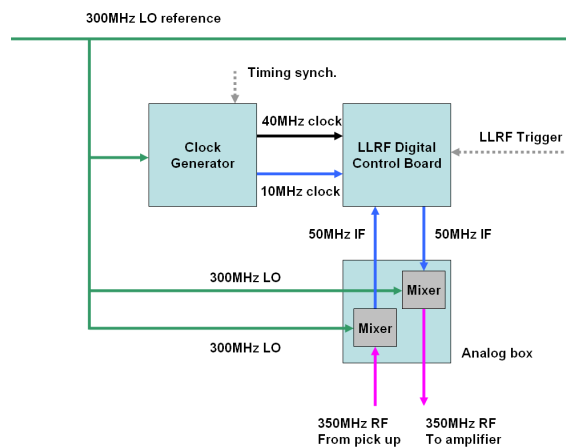

Figure 5: Block diagram of the modified LLRF system

The control system adopted general PI control algorithm using I/Q signal. The FPGA board clock was 10MHz and the latency of the control system was 1 $\mu$ s. The preliminary test results of the LLRF system by using 20MeV linac are shown in Fig. 5 and Fig. 6 respectively. The amplitude and phase of the cavity could be controlled

within 1% and 1 degree respectively as shown in the Figure.

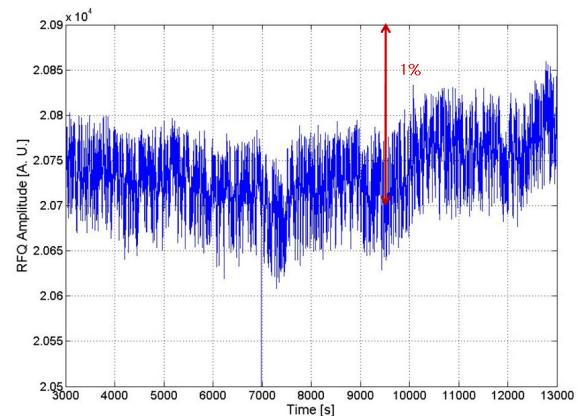

Figure 6: RF amplitude during 20MeV linac operation

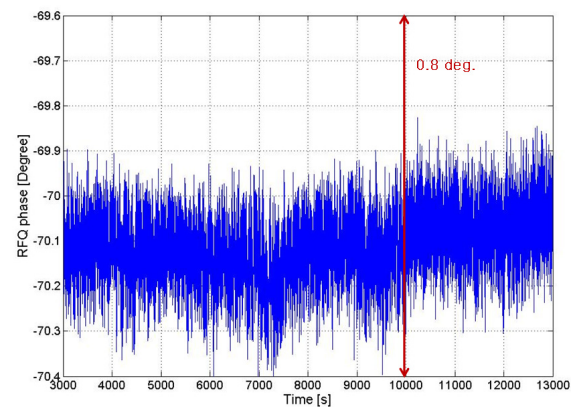

Figure 7: RF phase during 20MeV linac operation

## CONCLUSION

A 20MeV accelerator is operating not only for users but also for the test bench of the 100MeV accelerator components and beam study. These all efforts will be used as the basis for the commissioning and operation scenario of the 100MeV accelerator.

## REFERENCES

- [1] B. H. Choi, "Status of the PEPF" in these proceedings.
- [2] H. J. Kwon, et al., Journal of the Korean Physical Society, Vol. 54, No. 5, May 2009, 2015~2019.
- [3] Y. G. Song, et al., "Preliminary Implementation for the RF and Beam Current Monitor System Using EPICS" in these proceedings.