

# EIGHTY YEARS OF CYCLOTRONS

M.K. Craddock, University of British Columbia and TRIUMF, Vancouver, B.C., Canada

## Abstract

Lawrence's invention of the cyclotron in 1930 not only revolutionized nuclear physics, but proved the starting point for a whole variety of recirculating accelerators, from microtrons to FFAGs to synchrotrons, that have had an enormous impact in almost every branch of science and several areas of medicine and industry. Cyclotrons (i.e. fixed-field accelerators) themselves have proved remarkably adaptable, incorporating a variety of new ideas and technologies over the years: frequency modulation, edge focusing, AG focusing, axial and azimuthal injection, ring geometries, stripping extraction, superconducting magnets and rf... Long may they flourish!

## INTRODUCTION

It was 80 years ago this month that Ernest Lawrence [1] first announced successful tests of a “magnetic resonance accelerator” - what was later to become known by its nickname “cyclotron”. We can also celebrate the round-number anniversaries of a couple of cyclotron family members (counting from experimental demonstration):

- 60 years of isochronous cyclotrons (1950)
- 10 years of proton FFAGs (2000).

In the space available it's been impossible to do justice to the achievements of the whole 80 years at the same level of detail. Instead, I will concentrate on the earlier, perhaps less familiar, years, and only mention highlights from the later ones. For those seeking more detail, I recommend my sources [2-7] and also [8].

## INVENTION

Lawrence had moved from Yale to Berkeley in 1928, hoping to advance from research on the photoelectric effect to nuclear physics – the exciting new field promised by Rutherford's 1919 Manchester discovery that nuclear reactions could be induced by MeV particles – and especially exciting if radioactive sources could be replaced by intense beams accelerated artificially!

In the 1920s dc voltages >200 kV were hard to produce and control. But perhaps energy could be added in a series of low-voltage steps, using pulsed or ac voltages, synchronized to the particle's arrival at the accelerating gaps: "resonance acceleration"?

The first such proposal, by Gustav Ising in Stockholm (1924), was to feed high-voltage pulses by transmission line to a series of drift tubes. But nothing was built, and publication in Swedish had little impact. His work was however noted by a Norwegian grad student in Germany, Rolf Widerøe, who in 1928 built a two-gap linac powered by a 1-MHz 25-kV oscillator, accelerating Na<sup>+</sup> and K<sup>+</sup> ions to ~50 keV [9]

At Berkeley, the 27-year-old Ernest Lawrence came across Widerøe's article in 1929. Interestingly, the paper had also reported an unsuccessful attempt to build a "beam

transformer" - i.e. a betatron, where particles circulating in a magnetic field would be accelerated by raising the field – attributing his failure to inadequate “stabilization” – i.e. focusing – by the field. Perhaps this juxtaposition led Lawrence to consider combining the drift tubes with the magnetic field, using the latter to return the particles repeatedly to the same accelerating gaps - but not understanding German, he luckily missed the focusing caveat.

When Lawrence worked out the dynamics, he found an unexpectedly favourable result: for a particle with mass *m*, charge *q*, moving with velocity *v* normal to uniform magnetic induction **B**, the Lorentz Force **F** = *q v* × **B** produces a circular orbit, and

$$q \mathbf{v} \times \mathbf{B} = m \mathbf{v} \dot{\omega}^2 = m \omega \mathbf{v}$$

“*r* cancels *r*”, as Lawrence explained excitedly to each of his students, so that the “cyclotron frequency” is independent of *v* and the orbits are “isochronous”:

$$\omega = \frac{qB}{m}$$

The electrodes can therefore be excited at a fixed rf frequency, the particles will remain in resonance throughout acceleration, and a new bunch can be accelerated on every rf voltage peak, allowing continuous-wave (cw) operation. Also radius is directly proportional to velocity: *r* = *mv*/*qB*.

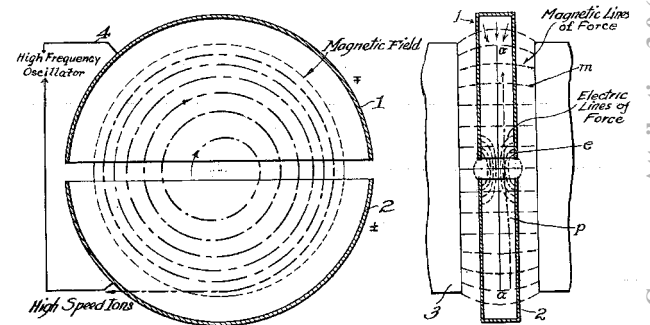

Figure 1: The cyclotron concept, from Lawrence's patent.

Early in 1930 Lawrence persuaded Nels Edlefsen, who had just completed his Ph.D., to join him in experimental work. Two rather crude models were built, one with dees formed by silvering a flattened glass flask, the other with copper “duants”. They observed signals on a detector at the outer edge, though no definite resonance, but by September felt able to publish an optimistic report [1].

That month two new students arrived: Dave Sloan, who was set to work on a linac (and by December had achieved 200-keV Hg ions with 11-kV rf, and in 1931 1.26-MeV Hg with 25-kV rf), and Stanley Livingston, on the cyclotron. He also had rapid success, building a new all-brass 4-inch model (Figure 2), finding clear evidence of magnetic resonance in November, and 13-keV protons. By January 1931 Lawrence had obtained a stronger magnet and the energy was raised to 80 keV.



Figure 2: The 4-inch cyclotron vacuum chamber, showing the single dee, the deflector, and G. Seaborg's left hand.

Several people had considered the cyclotron idea before Lawrence: Gabor (1924), Flegler (1926, discouraged by Widerøe's doubts about orbit stability), Steenbeck (1927) – but none had published or built anything. Szilard filed a patent (1929), but the only experimental work was by Thibaud in Paris following Lawrence's publication, and he did not report any success. The credit for an invention does not lie just in having an idea - but in going on to show that it works! On that basis, Lawrence's claim is secure - an important one, as the cyclotron principle is the basis of all circular accelerators except the betatron.

### EARLY CLASSICAL CYCLOTRONS

In what became a familiar style, Lawrence quickly moved to acquire larger and stronger magnets. First came the 11-inch (referring to the pole diameter), with which he and Livingston were able to achieve a world-record of 1.22-MeV protons in January 1932. Interestingly, their publication [10] shows a clear understanding of the importance of axial focusing, and how the magnetic and electric fields provide it (*cf.* Figure 1). But with no nuclear physics experience, in April 1932 they lost the race for nuclear disintegration to Cockroft and Walton, who had used a mere 600-keV cascade generator.

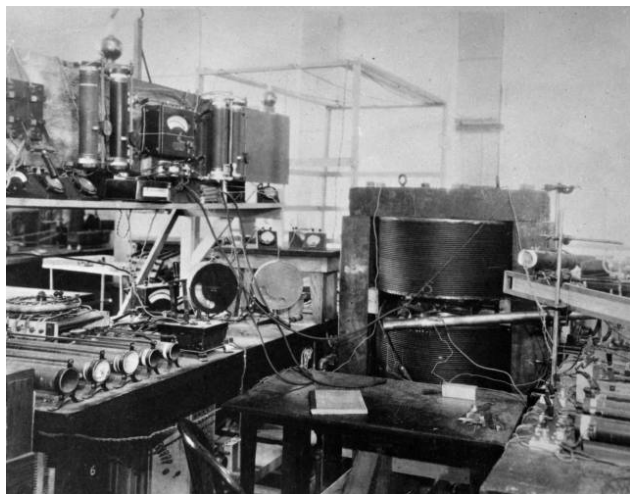

Figure 3: The 11-inch cyclotron and lab bench equipment.

This was followed in 1933 by the 27-inch, based on a war-surplus Federal Telegraph Co. Magnet, (Figure 4) which by 1936 was producing 20- $\mu$ A beams of 6.3-MeV deuterons. A larger 37-inch pole was then installed, yielding 100- $\mu$ A beams at 8.5 MeV in 1938. This was the work-horse for Berkeley nuclear physics in the 1930s, and also the provider of radioisotopes as tracers for novel studies in chemistry, botany, zoology and medicine - and for medical treatments too, led by Lawrence's brother John. In 1938 it could be claimed that "More new isotopes have been made artificially than occur in Nature".

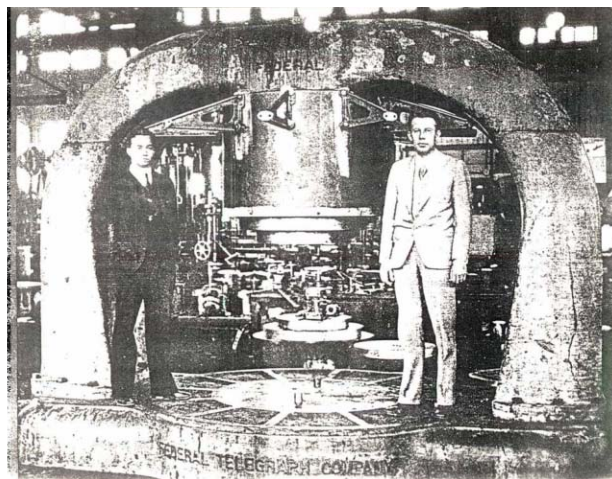

Figure 4: Livingston (left) and Lawrence with the 27-inch (later 37-inch) cyclotron.

The medical work got results. A local philanthropist helped to fund the Crocker Medical Laboratory and cyclotron – a 200-ton 60-inch machine that by 1940 was yielding 200- $\mu$ A beams of 16-MeV deuterons. Not only was the nuclear physics reach extended (it produced the first six transuranic elements) but the first neutron therapy program was established, with ~200 patients being treated.



Figure 5: Setting up a patient for neutron therapy.

Berkeley's success of course led to interest elsewhere. By 1940 there were 24 cyclotrons operating in the U.S., 3 in Japan, 2 each in Britain and the USSR, and one each in Denmark, France, Germany and Sweden.



The late 1930s yielded a firmer theoretical understanding of cyclotron beam dynamics. Rose [11] and Wilson [12] almost simultaneously produced analyses of the axial focusing provided by the electric and magnetic fields. For the latter,  $H(r)$ , each of them showed that the axial tune (as it was later named) is given by:

$$v_z = \sqrt{-\frac{r}{H} \frac{\partial H}{\partial r}}$$

Radial motion was apparently of no concern. If they had treated that as well, maybe today we'd be speaking of "cyclotron oscillations", not "betatron oscillations".

Bethe and Rose [13] also studied the effect on the longitudinal motion of an ion's relativistic increase in mass as it gains energy. They concluded that the phase drift resulting from the drop in angular frequency  $\omega$  would limit deuteron energies to  $8\sqrt{[V(\text{kV})/50]}$  MeV. Buoyed up by a Nobel Prize, Lawrence's plans for a huge 184-inch cyclotron were unaffected – he would just run the dees at 1 or 2 MV – and work began on the 4,300-ton magnet.



Figure 6: The 184-inch magnet with the UCRL staff.

### SYNCHROCYCLOTRONS

World War II did what Bethe couldn't, though, and prevented installation of the vacuum tank and rf. By its end Veksler and MacMillan had proved that phase stability was possible for a changing rf frequency, and the way was open to try doing that so as to match the decreasing  $\omega$  of an accelerating ion. This was first tried by Richardson, Mackenzie *et al.* [13] in 1946, by shimming the 37-inch magnet to simulate the frequency drop expected for deuterons being accelerated to 200 MeV, and installing frequency-modulated rf. When told of their success, Reg Richardson recalled [4], Lawrence "... rushed out... and [seeing] a truck carrying one of the huge dee stems necessary for 1 MV....told the driver to turn around and take the tank back to storage – or maybe the dump!"

The rf system for the 184-inch was immediately redesigned and by the end of 1946 it had been brought into operation as a synchrocyclotron, delivering 190-MeV deuterons, 380-MeV alphas and (later) 350-MeV protons - revolutionary steps in ion energy. The 37-inch was also

fully converted to operate as a synchrocyclotron, and was later moved to UCLA.

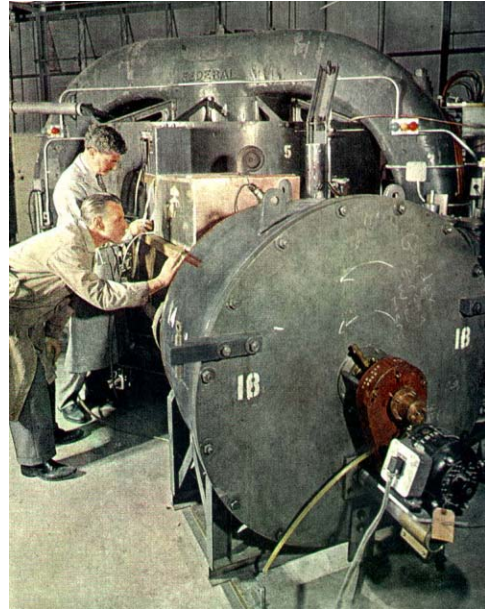

Figure 7: Lawrence and Richardson (rear) with the 37-in., showing the large rotating capacitor for fm operation.

The high energies they made available, together with their ease of operation, led to 10 more large synchrocyclotrons being built from 1946-54 (Table 1). They made possible controlled experiments with pions and muons, opening up the new field of particle physics. They also provided the first programmes of ion beam therapy, which was pioneered at Berkeley (1952), Uppsala (1954) and Harvard (1961). The price for their high energies, though, was pulsed operation and low (<1  $\mu\text{A}$ ) intensities, so that, for physics research at least, the advent of cw isochronous cyclotrons left them uncompetitive,

Table 1: Large synchrocyclotrons

Institute	Pole diameter (m)	Magnet wt. (t)	Proton energy (MeV)	Date first operated
UCRL Berkeley	4.70	4300	350	1946
			740	1957
U. Rochester	3.30	1000	240	1948
Harvard U.	2.41	715	160	1949
AERE Harwell	2.80	660	160	1949
Columbia U.*	4.32	2487	380/560*	1950
McGill U.	2.29	216	100	1950
U. Chicago	4.32	2200	450	1951
GWU Uppsala*	2.30	650	187	1951
Carnegie I.T.	3.61	1500	450	1952
U. Liverpool	3.96	1640	400	1954
LNP Dubna*	6.00	7200	680	1954†
CERN Geneva	5.00	2560	600	1958
NASA SREL	5.00	2765	590	1965
PNPI Gatchina	6.85	7874	1000	1967†
IPN Orsay	3.20	927	200	1977†

\* Later modified with spiral sectors. † Still in operation

### ISOCHRONOUS CYCLOTRONS

Back in 1938 Llewellyn Thomas [14] (reacting to Bethe’s predicted energy limit) had pointed out a way to allow cyclotrons to be run isochronously (and thus with intense cw beams) at relativistic energies: the axial ( $z$ ) defocusing associated with rising field  $\langle B_z \rangle = \gamma B_0$  (and field index  $k = -\beta^2 \gamma^2$ ) may be countered by an azimuthally varying field (AVF)

$$B_z(\theta) = \langle B_z(\theta) \rangle (1 + f \cos N\theta).$$

This produces a non-circular ‘scalloped’ orbit, and a  $qvrB_0$  component of  $F_z$ , everywhere a restoring force, to counter the defocusing  $qv_0B_r$  (though unstable for  $N < 3$ ):

$$v_z^2 = -\beta^2 \gamma^2 + \frac{1}{2} f^2$$

- a simple result arising from some intimidating algebra.

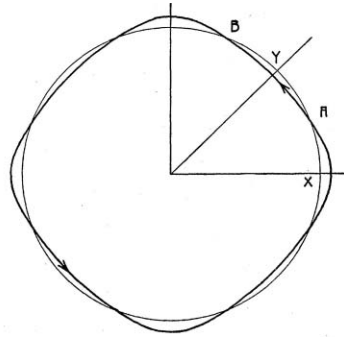

Figure 8: Left: L.H. Thomas; Right: Scalloped orbits.

Thomas’s idea was neglected for 12 years, possible reasons being the perceived difficulty of creating pure  $\cos N\theta$  fields, the onset of World War II, and the success of synchrocyclotrons. But in 1950 an apparent lack of uranium reserves led to a crash US program to breed fissile isotopes by neutron irradiation. The Livermore Materials Test Accelerator was to be a 350-MeV, 500-mA cw deuteron linac (and estimated to cost \$300M). Alvarez built Mark I, the first 18-m-diameter 18-m-long section (the biggest vacuum tank ever?), achieving 50 mA at 10 MeV in 1953, with 18 MW rf.

Back at Berkeley, Richardson argued that a 300-MeV Thomas cyclotron could be built at much lower cost. In 1950, he and some colleagues built two 3-sector electron models [15] (Figure 9). Like classical cyclotrons they

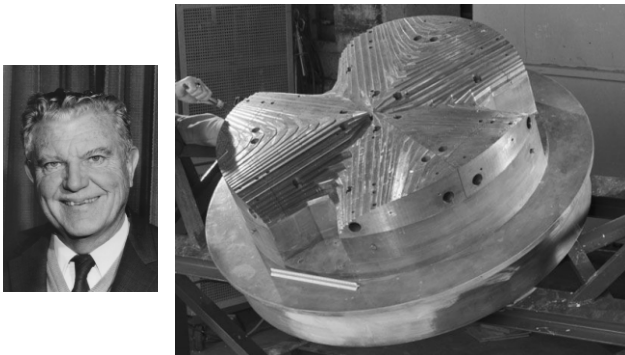

Figure 9: Reg Richardson and one pole of the second electron model, showing the harmonically-contoured hills.

required very precise shaping of the magnetic field, but 54 circular trim coils enabled this to be done more efficiently than with clumsy steel shims. Electrons were successfully accelerated to  $\beta = 0.5$  (the same as 300-MeV deuterons) and extracted with 90% efficiency – but the work was not declassified till 1956.

### Radial-sector Cyclotrons

Several classical cyclotrons were modified with radial sectors in the 1950s to provide stronger axial focusing and higher beam intensity (Los Alamos, MIT,..) - but were not made isochronous. The first sector-focused ion cyclotron was completed by Heyn and Khoe at Delft in 1958 [16]. It had 4 sectors, a pole diameter of 86 cm and a top proton energy of 12.7 MeV. The hill pole-tips were carefully shaped (Figure 10).

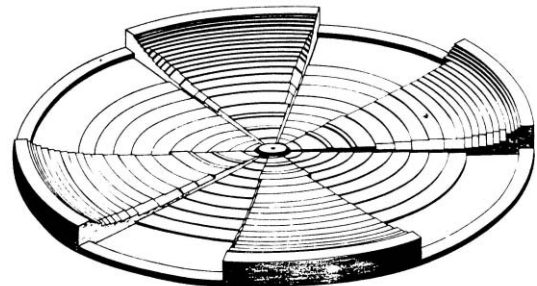

Figure 10: Hill and valley “shims” on the Delft cyclotron.

Others quickly followed (Table 2). Notice that their energies are limited to ~50 MeV/u by the difficulty of achieving high flutter in a compact magnet. To reach higher energies for physics research, designers turned to spiral sectors. Nevertheless, there has proved to be an enormous market for low-energy cyclotrons for radio-isotope production for industry and medicine. Over 300 radial-sector cyclotrons are now installed around the world, produced by at least 8 companies.

Table 2: Early radial-sector cyclotrons.

Location	Pole diameter (m)	Sectors	Energy (MeV/u)	First beam
Delft	0.86	4	12.7 (p)	1958
Birmingham	1.02	3	5.5 (d)	1961
Moscow	1.50	3	16 (d)	1961
Karlsruhe	2.25	3	25 (d)	1962
Orsay	1.20	3	17 ( $\alpha$ )	1965
Milan	1.66	3	45 ( $H^-$ )	1965

### Spiral-sector Cyclotrons

In 1955 Kerst [17] had suggested using spiral sectors to provide “strong” alternating edge focusing in FFAGs. His idea was quickly adopted for sectored cyclotrons. For an isochronous field the axial tune formula becomes:



$$v_z^2 = -\beta^2\gamma^2 + \frac{N^2}{N^2-1} F^2(1 + 2\tan^2 \varepsilon)$$

where the magnetic flutter  $F^2 \equiv \frac{[\langle B_z(\theta) \rangle - \langle B_z \rangle]^2}{\langle B_z \rangle^2}$ ,

$\varepsilon$  is the spiral angle, and there are  $N$  sectors. The powerful  $2\tan^2\varepsilon$  term enhances the flutter focusing  $\times 3$  for  $\varepsilon = 45^\circ$ . Spiralling is now used for most proton machines  $>40$  MeV, and has allowed designs up to 12 GeV. The earliest spiral-sector cyclotrons are listed in Table 1.

Table 3: Early spiral-sector cyclotrons

Institute	Pole diameter (m)	Sectors	Max <sup>m</sup> spiral	Energy (MeV)	Date first operated
UCLA	1.25	4	47°	50 H <sup>-</sup>	1960
UCRL Berkeley	2.24	3	56°	60 p	1961
U. Colorado	1.32	4	45°	30 H <sup>-</sup>	1962
Oak Ridge NL	1.93	3	30°	75 p	1962
U. Michigan	2.11	3	43°	37 p	1963
U. Manitoba	1.17	4	48°	50 H <sup>-</sup>	1964
Michigan S.U.	1.63	3	10°	56 p	1965
V.U.Amst <sup>t</sup> dam	1.40	3	37°	33 p	1965
AERE Harwell	1.78	3	45°	53 p	1965

The first to come into operation was the UCLA 50-MeV cyclotron [18] (Figure 11), notable for its very compact design, its use of spiral in-valley rf electrodes, and adoption of Colorado's innovation of accelerating H<sup>-</sup> ions [19], making it possible to extract the beam with 99% efficiency by stripping.

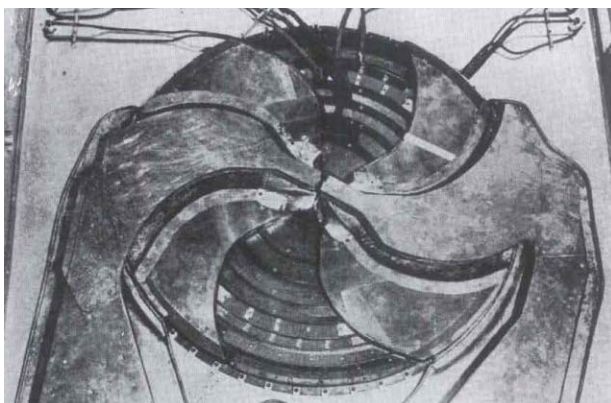

Figure 11: The UCLA 50-MeV cyclotron, with spiral dees.

The most relativistic spiral-sector cyclotron ever to operate was the Oak Ridge Analogue II [20] (Figure 12), an electron model for the proposed Mc<sup>2</sup> Cyclotron meson



Figure 12: The Oak Ridge Analogue II electron model.

factory, in which protons were to be accelerated to 810 MeV in an 8-sector magnet with 12-m diameter poles. In the model the electrons reached the corresponding energy of 465 keV ( $\beta = 0.86$ ), and were extracted with 80% efficiency with the help of the  $\nu_r = 2$  resonance.

Isochronous cyclotrons have been remarkably receptive to adaptations, the most notable being:

- External injection of beam
- Injection or extraction by stripping
- Separate sector magnets
- Superconducting technology.

Axial injection, in particular, makes it possible to inject beams at low energy from the large or complex sources needed to produce negative, polarized or heavy ions. Two types of 90° electrostatic deflector were developed, the mirror inflector by Powell [21] in Birmingham (8-kV for 10-keV deuterons), and the spiral inflector by Belmont [22] in Grenoble (15-kV for 50-kV protons).

Stripping is an effective tool for both heavy ions and negative hydrogen ions. For H<sup>-</sup> ions it not only makes possible very efficient extraction, but the extraction of multiple beams – a feature often employed in isotope-production cyclotrons. The TRIUMF 70-520 MeV cyclotron routinely extracts 3 beams simultaneously at different energies [23], and plans to add another (Figure 13).

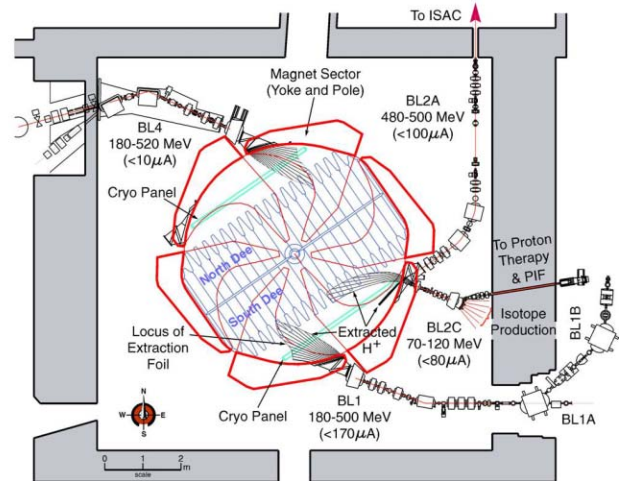

Figure 13: The TRIUMF cyclotron permits simultaneous extraction of four beams at different energies.

### Separate-sector Ring Cyclotrons

This powerful concept was first proposed by Hans Willax [24] for the 590-MeV Swiss meson factory (Figure 14). Each sector magnet (hill) has its own yoke and coil, while the valleys are field-free and available for rf, injection, extraction and diagnostic equipment.

With small pole gaps the magnets are very efficient and produce hard-edge fields with flutter  $F^2 \geq 1$ , making it possible to reach  $\beta\gamma \approx 1$  ( $\approx 400$  MeV/u) with radial sectors. This has made the design popular for large heavy-ion cyclotrons, such as the Lanzhou K450 and the four at RIKEN, ranging from K540 to K2600 (the last with the additional novelty of using superconducting magnets).

In the case of PSI it was serendipitously found possible to obtain almost complete turn separation at extraction,

where  $\nu_r \approx 1.5$ , by using high energy-gain per turn with very short bunches, and injecting off centre. With 99.97% extraction efficiency, 2-mA external beams are routine, and 3-mA beams are planned. PSI's current 1.3-MW beam remains the world's most powerful.

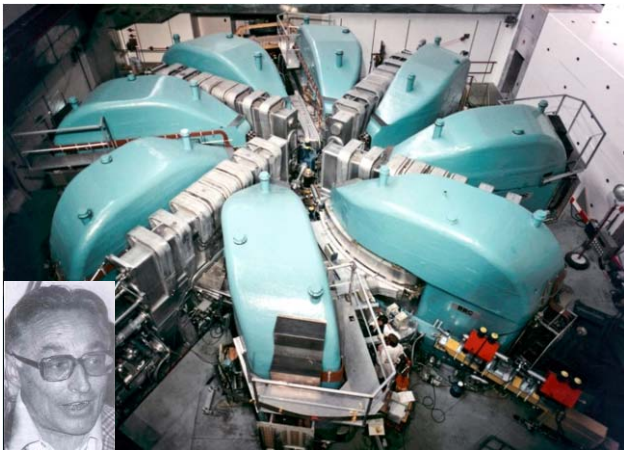

Figure 14: The PSI 590-MeV ring cyclotron, showing the 8 spiral magnets and four rf cavities. Inset: Hans Willax.

**Compact Superconducting Cyclotrons**

Superconducting coils can provide magnetic fields at least 3 times higher than those of conventional magnets, allowing the dimensions to be reduced by the same factor for a given ion momentum, and the cost even more (not to speak of the power bill). The pioneers responsible for this development were Bigham *et al.* [25] at AECL, Chalk River, and Blosser *et al.* [26] at MSU (Figure 15). The main coil is typically housed in an annular cryostat, while the conventional room-temperature components, including pole tips, rf accelerating system, vacuum system, and ion source, are inserted in the warm bore of the cryostat from top and bottom. The largest compact superconducting cyclotron, the K1200 at MSU, is only 2.9 m in overall diameter, but can accelerate heavy ions to energies as high as 200 MeV/u.

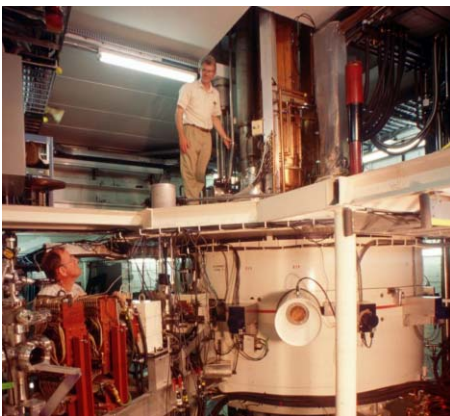

Figure 15: Left: The first superconducting cyclotron to operate, the MSU K500; Right: Henry Blosser.

Besides the several superconducting cyclotrons built for nuclear physics, an increasing number are being produced for particle therapy. The first was modest but innovative, a

50-MeV deuteron machine for neutron therapy, small enough to be mounted on a gantry and rotated around the patient. Now Varian-Accel produces a 250-MeV machine for proton therapy, while IBA's C400 will also deliver 400-MeV/u carbon ions.

**Separated Orbit Cyclotrons**

The separated-orbit cyclotron (SOC), in which the bending and focusing fields of the sector magnets are specially tailored for each orbit, was proposed by Russell [27] in the early 1960s for the acceleration of high-current (~50 mA) proton beams to GeV energies. Its complexity and cost, using normal magnets, deterred potential builders. However, a prototype superconducting SOC, the K85 TRITRON, was built and demonstrated in Munich [28]. This was the ultimate in superconducting cyclotron design, since the six rf accelerating cavities as well as the magnet were superconducting. The entire cyclotron was enclosed in a 3.5-m diameter vacuum chamber, with the vacuum being maintained by cryogenic pumping. The magnets were very modest in size, consisting of 12 sectors, each 6 cm high, about 90 cm in radial extent, and containing twenty 2-cm x 2-cm channels containing the coils, copper shielding and a 1-cm diameter beam aperture (Figure 16). A 40-MeV S<sup>14+</sup> ion beam from an MP tandem was accelerated through six turns to 72 MeV.

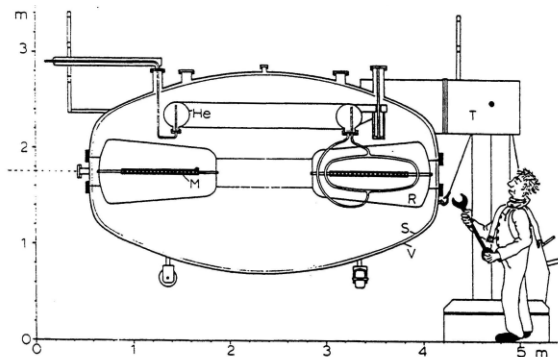

Figure 16: The K85 TRITRON SOC. The thin black bar M indicates a magnet; R is an rf cavity.

**FFAG ACCELERATORS**

Fixed-Field Alternating-Gradient (FFAG) accelerators occupy the missing niche in the family of fixed magnetic field (cyclotron) accelerators [29] (Figure 17). They share

Magnetic field variation B(θ)	Fixed Frequency (CW beam)	Frequency-modulated (Pulsed beam)
Uniform	Classical	Synchro-
Alternating	Isochronous	FFAG

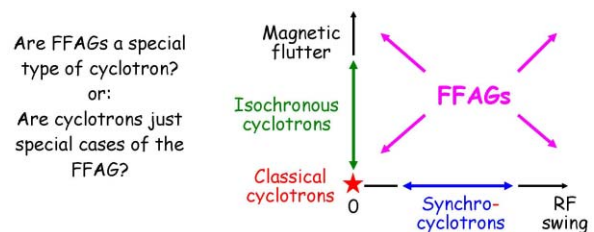

Figure 17: The cyclotron (fixed-field) accelerator family.

Copyright © 2011 by the respective authors — cc Creative Commons Attribution 3.0 (CC BY 3.0)



the features of both synchro- and isochronous cyclotrons, operating in pulsed mode with fm rf, and acquiring axial focusing through azimuthal field variation.

The basic idea, conceived independently by Ohkawa [30], Kolomensky [31] and Symon [32] in 1953-4, was to introduce “strong” AG focusing to fixed-field accelerators for the GeV region, either by alternating positive and negative gradient magnets with radial edges (Figure 18), or by using spiral sector magnets (Kerst [17]).

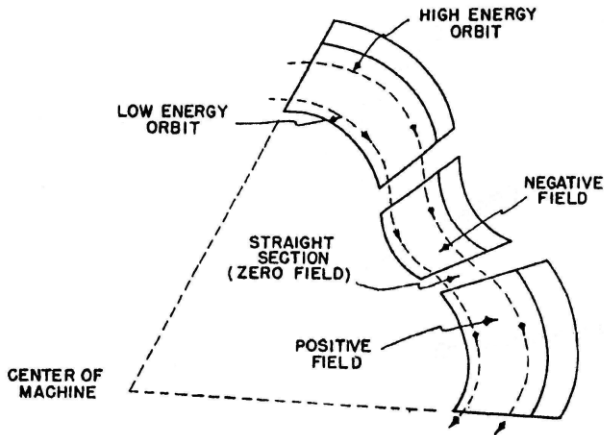

Figure 18: Radial-sector FFAG magnets and orbits.

Compared to AG synchrotrons they would have larger acceptances and pulse repetition rates, and hence much higher beam currents. Their spiral orbits would require wider magnets, rf cavities and vacuum chambers, but the width would be limited by using high field gradients  $k$ . The most intensive studies were carried out at the Mi-West Universities Research Association (MURA), where the “scaling” principle was adopted and several successful electron models built (Figure 19).

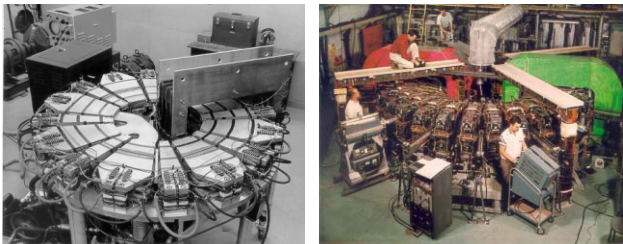

Figure 19: MURA radial-sector electron model FFAGs: left: 400-keV; right: 50-MeV two-way accelerator.

“Scaling” means keeping the orbit shape, optics and tunes fixed for all energies, and thus avoiding crossing any betatron resonances with possible loss of beam current or quality. To first order, for many cells ( $N \gg 1$ ):

$$v_r^2 \approx 1+k \quad v_z^2 \approx -k + F^2(1+2\tan^2 \varepsilon),$$

so the MURA scaling recipe was to keep the field index  $k$ , flutter  $F^2$ , and spiral angle  $\varepsilon$  constant for all radii, resulting in the field and momentum ( $p$ ) laws:

$$\langle B_z \rangle = B_0 (r/r_0)^k \quad p = p_0 (r/r_0)^{k+1}.$$

In spite of the success of the electron models, none of MURA’s proposals for proton FFAGs (0.5, 10, 15, and 20

GeV) were funded. Nor were Argonne’s and Jülich’s later proposals for 1.5-GeV 4-mA spallation neutron sources.

The first proton FFAG was Mori’s 1-MeV radial-sector machine at KEK in 2000 [34]. Proton FFAGs are more challenging than those for electrons, as frequency modulation cannot be avoided. The mechanical modulators used in synchrocyclotrons had been notoriously unreliable. Mori instead loaded his cavities with Finemet alloy, producing high fields with low  $Q$  ( $\approx 1$ ), allowing broadband operation. He followed this with a 12-cell 150-MeV FFAG at KEK and a 3-stage FFAG complex at Kyoto University Research Reactor Institute (KURRI) that is now in use for the world’s first tests of Accelerator-Driven Subcritical Reactor (ADS) operation (Figure 20). Three more scaling FFAGs have been built in Japan (one for electron irradiation, one for BNCT neutron therapy and the third for muon momentum cooling), and several others are being studied.

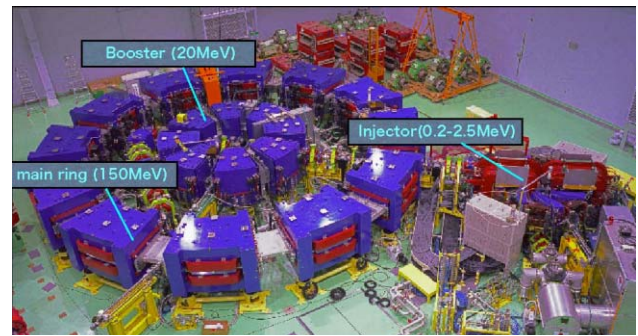

Figure 20: The 3-stage FFAG complex at KURRI.

### Non-scaling FFAGs

The recent resurgence of interest in FFAGs stems not only from the above work but also from Mills’s [34] and Johnstone’s [35] 1997 suggestion of building non-scaling FFAGs for the muon accelerators in a neutrino factory – muons being so short-lived that the rapid acceleration required leaves no time for resonances to spoil the beam. Johnstone proposed a “linear” non-scaling (LNS) design using constant negative-gradient magnets (Figure 21). This offers a number of advantages: greater momentum compaction (hence narrower radial apertures); minimal orbit-time variation (allowing cw operation at fixed rf frequency); no multipole field components to drive higher-order betatron resonances; simpler construction (quadrupolar rather than  $B \propto r^k$ ). LNS-FFAGs have been chosen for the 12.5-25 and 25-50-GeV muon stages of the Neutrino Factory International Design Study. EMMA, a 10-20-MeV electron model of a 10-20-GeV muon FFAG is currently undergoing beam commissioning at Daresbury.

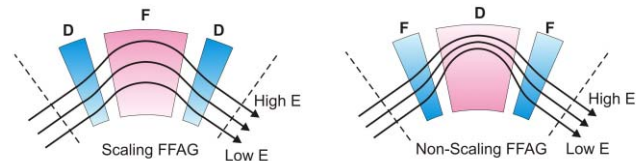

Figure 21: Orbits in scaling and linear non-scaling FFAGs (colour density denotes field strength).

Non-linear non-scaling designs are also being studied, particularly for cancer therapy. But the most interesting for a cyclotron audience is perhaps one of Rees's designs using 5-magnet "pumpkin" cells: an 8-20-GeV isochronous muon accelerator (Figure 22) with nearly radial magnet edges that remains vertically focusing up to  $\gamma=190$  (and  $\beta^2\gamma^2 = 36,100$ )! Using three magnet types per cell, rather than two, provides extra degrees of freedom, so that the axial focusing term is no longer restricted to  $F^2(1+2\tan^2\epsilon)$ .

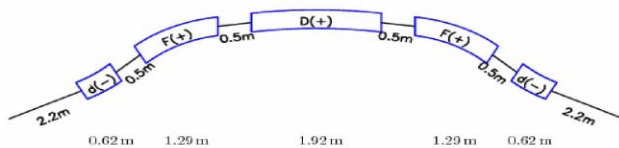

Figure 22: Five-magnet "pumpkin" cell.

## FINAL THOUGHTS

Over 80 years, Lawrence's magnetic resonance principle has proved remarkably productive as the basis for all modern "circular" accelerators. Classical cyclotrons opened up nuclear physics, and synchrocyclotrons particle physics, while isochronous cyclotrons have provided ion beams of unrivalled intensity in the 10-600 MeV/u range not only for physics but increasingly for other sciences and medicine. FFAGs too are enjoying a resurgence in their original scaling form, and have recently been discovered to offer interesting possibilities in a variety of non-scaling forms. Let's wish the fixed-field accelerator family another productive 80 years!

## REFERENCES

[1] E.O. Lawrence, N. Edlefsen, *Science*, **72**, 376 (1930).  
 [2] J.L. Heilbron & R.W. Seidel, *Lawrence and His Laboratory*, v.1 (U. California Press, 1989); <http://ark.cdlib.org/ark:/13030/ft5s200764/>  
 [3] M.S. Livingston, *The Development of High-Energy Accelerators* (Dover, 1966).  
 [4] M.S. Livingston, *The History of the Cyclotron*, Proc. 7<sup>th</sup> Cyclotron Conf., 635 (Birkhauser Verlag, 1975)  
 [5] J.R. Richardson, *A short Anecdotal History of the Cyclotron*, Proc. 10<sup>th</sup> Cyclotron Conf., 617 (IEEE, 1984).  
 [6] F.T. Cole, *Oh Camelot! A Memoir of the MURA Years*; Proc. Cyclotrons 2001, Supplement; <http://www.jacow.org>  
 [7] L. Jones, F. Mills, A. Sessler, K. Symon, D. Young, *Innovation Was Not Enough* (World Scientific, 2009).  
 [8] M.K. Craddock, K.R. Symon, *Cyclotrons and FFAGs*, Rev. Acc. Sci. Tech. **1**, 65 (2008).

[9] R. Wideröe, *The infancy of particle accelerators* (Braunschweig: Vieweg, 1994) p.41.  
 [10] E.O. Lawrence, M.S. Livingston, *Phys. Rev.* **40**, 19 (1932).  
 [11] M.E. Rose, *Phys. Rev.* **53**, 392-408 (1938).  
 [12] R.R. Wilson, *Phys. Rev.* **53**, 408-20 (1938).  
 [13] J.R. Richardson, K.R. MacKenzie, E.J. Lofgren, B.T. Wright, *Phys. Rev.* **69**, 669 (1946).  
 [14] L.H. Thomas, *Phys. Rev.* **54**, 580-8 (1938).  
 [15] E.L. Kelly, R.V. Pyle, R.L. Thornton, J.R. Richardson, B.T. Wright, *Rev. Sci. Instr.* **27**, 492 (1956).  
 [16] F. Heyn, K.T. Khoe, *Rev. Sci. Instr.* **29**, 662 (1958).  
 [17] D.W. Kerst, K. M. Terwilliger, K.R. Symon, and L.W. Jones, *Phys. Rev.* **98**, 1153 (A) (1955).  
 [18] D.J. Clark, J.R. Richardson, B.T. Wright, *Nucl. Instr. & Meth.* **18-19**, 1-24 (1962).  
 [19] D.A. Lind, J.J. Kraushaar, R. Smythe, M.E. Rickey, *Nucl. Instr. & Meth.* **18-19**, 62 (1962).  
 [20] J.A. Martin, J.E. Mann, *Nucl. Instr. & Meth.* **18-19**, 461-8 (1962).  
 [21] W.B. Powell, B.L. Reece, *Nucl. Instr. & Meth.* **32**, 325 (1965).  
 [22] J.L. Belmont, J.L. Pabot, Proc. 5<sup>th</sup> Cyclotron Conf., IEEE Trans. NS-13, 191 (1966); <http://www.jacow.org>  
 [23] J.R. Richardson, E.W. Blackmore, *et al.*, Proc. PAC'75, IEEE Trans. NS-22, 1402 (1975).  
 [24] H. Willax, Proc. 3<sup>rd</sup> Cyclotron Conf., CERN 63-19, 386 (1963); <http://www.jacow.org>  
 [25] J. Ormrod, C.B. Bigham *et al.*, Proc. PAC'77, IEEE Trans. NS-24, 1093-5 (1977); <http://www.jacow.org>  
 [26] H.G. Blosser, F. Resmini, Proc. PAC'79, IEEE Trans. NS-26, 3653-8 (1979); <http://www.jacow.org>  
 [27] F.M. Russell, *Nucl. Instr. & Meth.* **23**, 229 (1963).  
 [28] A. Cazan, P. Schütz, U. Trinks, Proc. EPAC'98, 556-8 (1998); <http://www.jacow.org>  
 [29] E.M. McMillan, *Particle accelerators*, in *Experimental Nuclear Physics III* (Wiley, 1959) 639.  
 [30] T. Ohkawa, Phys. Soc. Japan Symp. Nucl. Phys. (Tokyo, 1953).  
 [31] A.A. Kolomensky, V.A. Petukhov, M. Rabinovich, *Lebedev Phys. Inst. Report RF-54* (Moscow, 1953).  
 [32] K.R. Symon, *Phys. Rev.* **98**, 1152(A) (1955).  
 [33] M. Aiba *et al.*, Proc. EPAC'00, 581-3 (2000).  
 [34] F. Mills, Proc. 4<sup>th</sup> Int. Conf. Physics Potential and Development of  $\mu^+\mu^-$  Colliders, 1997, 693 (1998)  
 [35] C. Johnstone, *ibid.*, 696.  
 [36] G.H. Rees, *ICFA Beam Dynamics Newsletter* **43**, 74 (2007); <http://www-bd.fnal.gov/icfabd/Newsletter43>.