

STATUS OF 172 MHZ RF SYSTEM FOR VEPP-2000 COLLIDER

V.S.Arbusov, Yu.A.Biryuchevsky, A.A.Bushuev, E.I.Gorniker, E.K.Kendjebulatov, A.A.Kondakov, I.A.Koop, S.A.Krutikhin, Ya.G.Kruchkov, I.V.Kuptsov, G.Ya.Kurkin, N.V.Mityanina, S.V.Motygin, V.N.Osipov, V.M.Petrov, A.M.Pilan, A.M.Popov, V.P.Prosvetov, E.A.Rotov, I.K.Sedlyarov, Yu.M.Shatunov, A.G.Tribendis, V.N.Volkov, S.V.Volobuev,
The Budker Institute of Nuclear Physics, Acad. Lavrentiev prospect 11, 630090

Abstract

The description of storage ring VEPP-2000 RF system is given. The RF system consists of an RF generator with GU-101A tetrode in the output stage and with output power of 60 kW in CW mode, an accelerating cavity with higher order modes (HOM) damping and accelerating voltage of 120 kV and a control system providing tuning of RF cavity and control of accelerating voltage phase and amplitude.

Detailed description of operation of automatic frequency tuning system of choke-filter, which prevents a leakage of RF power of the accelerating mode to one (of two) HOM dumper, and a system of automatic frequency tuning of cavity operating mode is given.

Now the RF system is made, assembled and installed to the storage ring.

The results of RF system commissioning are given.

INTRODUCTION

VEPP-2000 electron-positron collider [1] will work at currents about 2×200 mA and beam energy up to 1000 MeV. RF system with 172 MHz "single-mode" cavity [2, 3, 6] will be used for damping beam coherent instabilities. 60 kW RF generator will compensate cavity losses and radiation beam losses. Control system will provide amplitude, frequency and phase stabilization of accelerating voltage and synchronization of beam transportation from BEP to VEPP-2000 storage ring.

CAVITY

Design of cavity with HOM damping (fig. 1) is described in [2, 3, 6]. Now the cavity is placed into storage ring (fig. 2). Measurements and commissioning results are given below.

Cavity RF-measurements

HOM spectrum measurement showed that quality factor (Q) of almost all HOM did not exceed 100. This result coincides with calculations satisfactorily [3, 6].

RF-measurements of accelerating mode field were carried out at coaxial HOM load (fig.1, pos.6) with three sampling loops azimuthally allocated by 120° . These measurements showed that RF field distribution is not azimuthally-symmetric, because there is a space dipole mode (TE₁₁) in this region. This mode arises from imperfect azimuthal symmetry of cavity. This mode contribution to cavity RF losses is negligible. A choke-filter auto-tuning system uses a sum signal from all three loops. It allows to compensate undesirable influence of dipole mode.

A coupling coefficient of the cavity coupler input is 2.7.

A sampling loop calibration was carried out.

Design changes

For frequency tuning range increase the cavity mechanical tuner (fig.1, pos.5) was modified and vacuum chamber bellow and cavity bellow (fig.1, pos.9) were

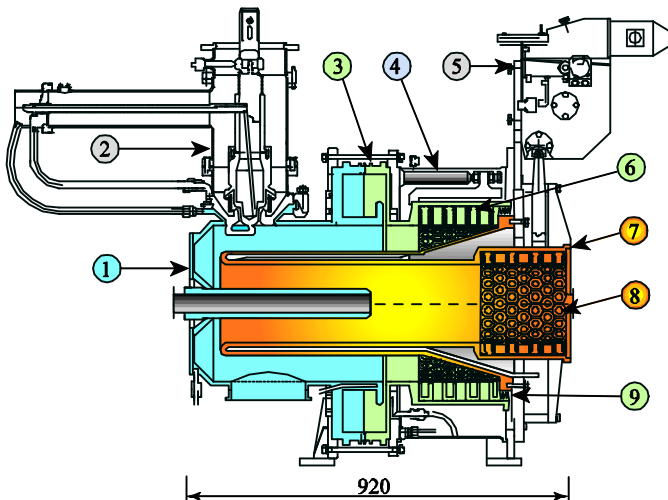

1. external cavity part with a copper wall,
2. coupler input,
3. choke filter with a flexible right wall,
4. choke-filter (thermal) tuner,
5. cavity (mechanical) tuner,
6. coaxial HOM load,
7. internal cavity part moved by mechanical tuner,
8. waveguide HOM load,
9. bellow.

Figure 1: Sketch of VEPP-2000 cavity.

replace by another ones with a longer motion.

To increase choke-filter frequency tuning speed, thermal tuner elements (fig.1, pos.4) with time constant about 8 minutes (aluminium rods having heating windings and working as griped elements) are been planned to replace by another elements with expected time constant about 1 minute (stainless steel stripes being heated by Peltje elements and working as stretchings).

Vacuum

Preliminary cavity heating at 200 °C during 10 hours allowed to achieve a cavity vacuum about $2 \cdot 10^{-7}$ Pa. Cavity training allowed to increase accelerating voltage to 90 kV at vacuum about $4 \cdot 10^{-7}$ Pa. Additional cavity training by RF field is needed for subsequent accelerating voltage rising.

Table 1: General parameters of the cavity.

Frequency	172.09 MHz
Quality factor Q	8300
Shunt impedance $\rho \cdot Q$	234 kOhm
Diapason (range) of frequency tuning	510 kHz
Accelerating RF voltage	120 kV
Cavity power losses	30 kW
RF power transmitted to a beam	24 kW
HOM shunt impedances	≤ 300 Ohm

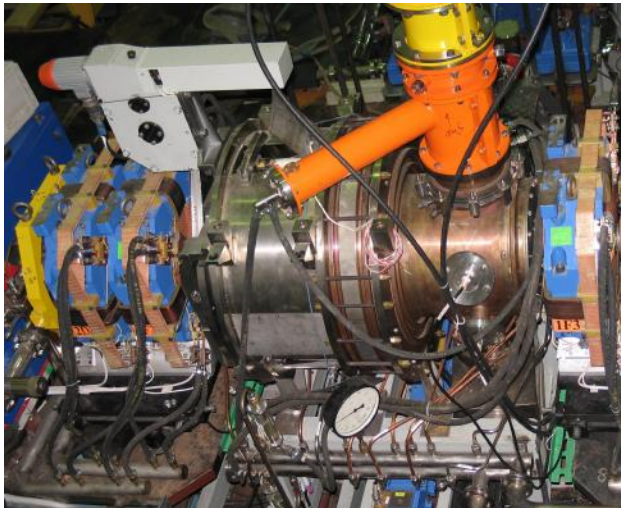

Figure 2: The cavity in the storage ring.

GENERATOR

RF generator is similar to the injector 180 MHz 130 kW RF generator of the FEL microtron-recuperator [4, 5,

6]. It is a three-stage tetrode power amplifier operated from a voltage-controlled modulator.

The generator was tested with matched load at output power of 60 kW in CW mode.

Table 2: Distribution of amplification and power on generator stages.

	Modulator	GU92-A	GU92-A	GU101-A
K_p		25	20	15
P_{operat}	8 W	200 W	4 kW	60 kW



Figure 3: RF generator with part of a feeder (to the right).

FEEDER

The RF generator and the cavity are connected with each other by the feeder. Feeder wave impedance is 75 Ohms and feeder diameter is 160/45 mm. The feeder has a U-type bend for electrical length adjusting from $N \cdot \lambda/2$ to $N \cdot \lambda/2 + \lambda/4$.

CONTROL SYSTEM

VEPP-2000 control system (fig. 4) consists of a few sub-systems:

1. ■ A modulator is used for control of cavity accelerating voltage or feeder current at adjusting, testing and operating conditions.
2. ■ Sub-system for cavity frequency adjusting. This sub-system operates with phase difference between feeder current and cavity voltage.
3. ■ Sub-system for choke-filter frequency adjusting. The sub-system operates with phase difference between cavity voltage and voltage of coaxial HOM load.
4. ■ Sub-system that stabilizes accelerating voltage phase relative to a master oscillator phase.
5. ■ Sub-system that provides an RF synchronization.
6. ■ Sub-system for synchronization of beam transfer from BEP to VEPP-2000 storage ring.

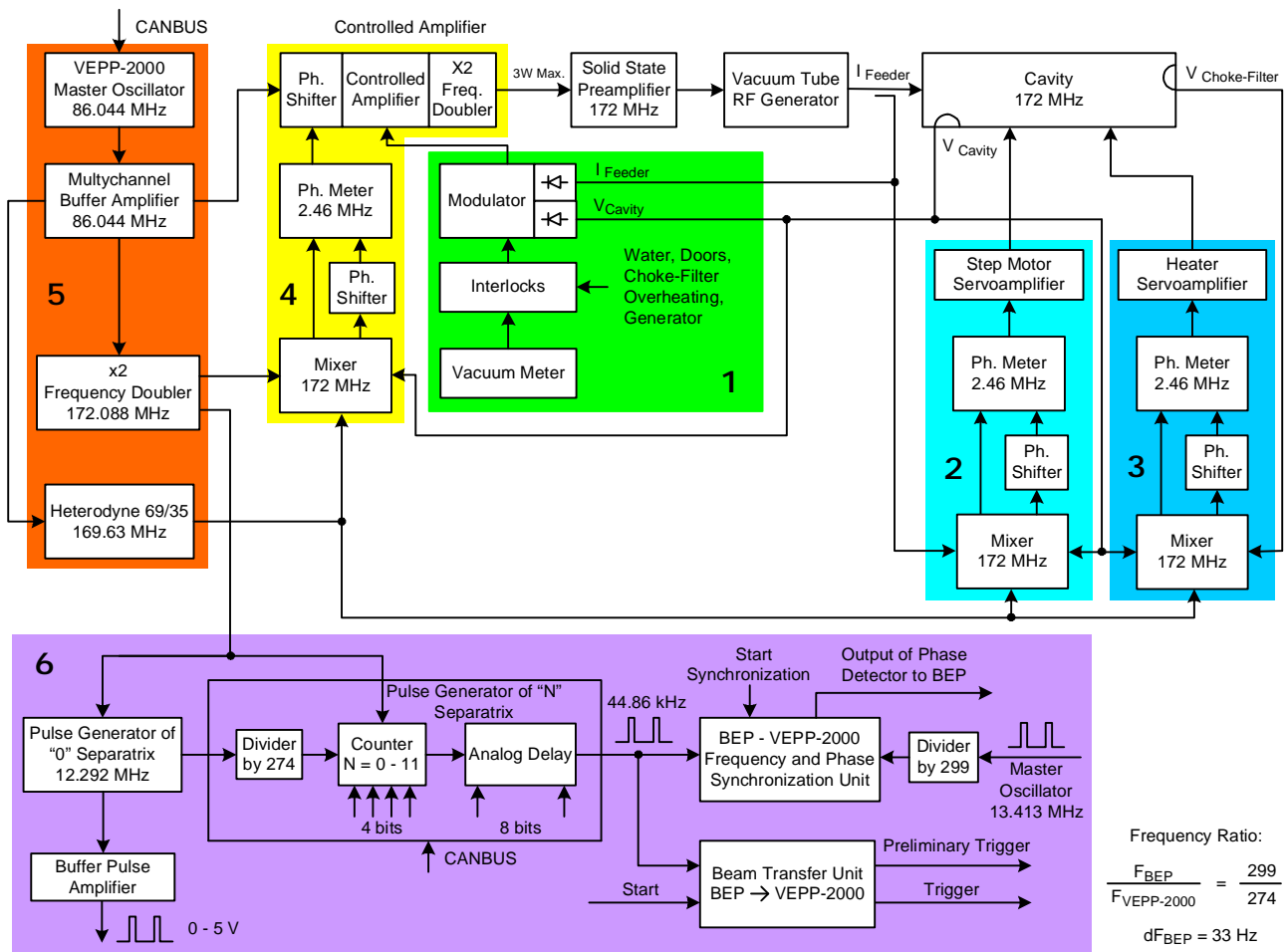

Figure 4: Control system block diagram.

Now VEPP-2000 control and synchronization system have been made completely. The beam transfer system is being commissioned.

CONCLUSION

- All parts of RF system have been installed to the storage ring.
- 90 kV accelerating voltage have been reached. Subsequent accelerating voltage rising is possible after additional training of multipactor discharge.
- The generator have been commissioned and tested with matched load at output power of 60 kW in CW mode. Now the generator is used for cavity training.
- VEPP-2000 control and synchronization system have been commissioned. The system of beam transfer from BEP to VEPP-2000 storage ring is being commissioned.

REFERENCES

- [1] Yu.M.Shatunov et al., "Project of a new electron-positron collider VEPP-2000", Proc. of EPAC 2000, Vienna, Austria, 2000.
- [2] V.N.Volkov et al., "VEPP-2000 single-mode cavity", 7th European Particle Accelerator Conferences, Austria Center Vienna, June 2000, p.2008-2010.
- [3] V.Volkov et al., "Single mode RF cavity for VEPP-2000 storage ring based collider", Proc. of EPAC 2004, Lucerne, Switzerland, 2004.
- [4] V.Arbutov et al., "RF system of Electron Injector for the Race-Track Microtron-Recuperator", HEACC'98, XVII International Conference on High Energy Accelerators. Dubna 1998.
- [5] V.Arbutov et al., "RF System of electron injector for the Race-track microtron-recuperator and results of its operation with electron beam", Problems of Atomic Science and Technology, v.4(35), 1999, p.26-28, NSC KiPT, Kharkov, Ukraine.
- [6] V.Arbutov et al., "172 MHz RF system for VEPP-2000 storage ring", RUPAC-2004.