

## DAΦNE STATUS AND PLANS

The DAΦNE Project Team\*

presented by G. Vignola

INFN, Laboratori Nazionali di Frascati (LNF), C.P. 13, 00044 Frascati, Italy

The  $e^+e^-$   $\Phi$ -factory DAΦNE has been approved and funded in 1990; the detailed engineering design started in 1991 and the construction is proceeding steadily.

The beginning of the collider commissioning, with a short term luminosity goal  $L = 1.3 \cdot 10^{32} \text{ cm}^{-2} \text{ sec}^{-1}$ , is scheduled for the end of 1996.

### I. INTRODUCTION

The main features of the  $e^+e^-$   $\Phi$ -factory DAΦNE have been described in detail elsewhere [1]. The project was approved and funded in 1990M and the detailed engineering design started in 1991. The construction of machine and experiments is proceeding steadily.

The accelerator complex layout is shown in Fig. 1. It consists of:

- $e^+e^-$  LINAC;
- $e^+e^-$  Accumulator/damping ring;
- twin ring collider (DAΦNE).

The tender phase is almost complete and all the various components are under construction. The beginning of the collider commissioning is scheduled for the end of 1996, and the start of experimental runs for mid 1997.

The design luminosity  $L = 5.2 \cdot 10^{32} \text{ cm}^{-2} \text{ sec}^{-1}$  should be achieved in a period of at least 2 years of continuous operation by pushing up the current and, at the same time, by fine tuning all machine parameters.

In the following, we will discuss briefly the main features and the status of the three accelerators and, in some more detail, the vacuum system, the RF cavity and the longitudinal feedback system for the collider.

### II. LINAC

The LINAC [2] is an S-band structure with a SLED type pulse compression system capable of accelerating electrons up to 800 MeV at 50 pps. In the positron mode of operation the first part of the LINAC (from the gun to the positron converter) is used to accelerate a 4A-10ns electron pulse at 250 MeV. The high-current performances of the LINAC have been successfully tested [3] at the TITAN Beta factory.

The LINAC (see Fig. 2) is now being installed at LNF and the beam tests are scheduled for May 95. It will be fully operational by December 95.

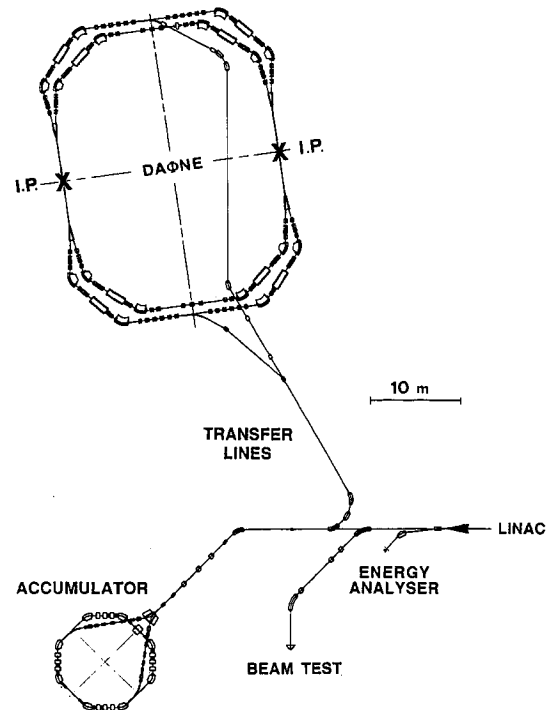

Figure 1: Layout of DAΦNE and its injector.

### III. ACCUMULATOR

The main parameters of the Accumulator/damping ring are shown in Table I. It has a compact 4 period structure, with a total length 1/3 of DAΦNE.

Table I - DAΦNE Accumulator Main Parameters

Energy (MeV)	510.0
Circumference [m]	32.56
Emittance, $\epsilon_0$ [mm-mrad]	0.26
Betatron tune, $\nu_x/\nu_y$	3.12/1.14
RF frequency, $f_{RF}$ [MHz]	73.65
Bunch average current [mA]	150
RF voltage [kV]	200
Bunch length $\sigma_z$ [cm]	3.8
Synchrotron radiation loss [keV/turn]	5.2
Damping time, $\tau_e/\tau_x$ [ms]	10.7/21.4

The Accumulator is used to store at 50 pps the required number of electrons (positrons) in one RF bucket and to damp the transverse and longitudinal emittance of the LINAC beam. The damped beam is extracted at  $\sim 1$  pps and injected into a single bucket in DAΦNE.

\* M. Bassetti, M.E. Biagini, C. Biscari, R. Boni, A. Cattoni, V. Chimenti, A. Clozza, S. De Simone, G. Di Pirro, H. Dong, A. Drago, S. Faini, A. Gallo, A. Ghigo, S. Guiducci, Y. He, H. Hsieh, F. Marcellini, C. Marchetti, M.R. Masullo, M. Migliorati, C. Milardi, M. Modena, L. Palumbo, L. Pellegrino, M. Preger, H. Qu, G. Raffone, C. Sanelli, F. Sannibale, M. Serio, F. Sgamma, B. Spataro, A. Stecchi, L. Trasatti, C. Vaccarezza, M. Verola, M. Vescovi, S. Vescovi, G. Vignola, D. Yao, M. Zobov.



Figure 2: DAΦNE LINAC during installation (April 95).

Oxford Instr. is the main contractor for the construction and the installation of the Accumulator, whose magnets are built by Tesla Eng.

The series production of magnets (designed and measured by LNF), vacuum chambers and other components is complete. The installation of the Accumulator, due to  $\sim 1$  year delay in the delivery of the Transfer Lines, built by Ansaldo Energia, is scheduled for September 95, while the beam tests will begin in January 96.

Due to the excellent magnetic field quality measured on the first Accumulator quadrupole ( $\Delta B/B = \pm 10^{-4}$  @  $\pm 3$  cm, instead of  $\pm 5 \cdot 10^{-4}$  requested by the Specs), we have decided to use in the DAΦNE long straights the same quadrupoles (60).

#### IV. DAΦNE

The major physics motivation for the construction of DAΦNE is the observation of direct CP-violation in  $K_L$  decays, i.e. the measurements of  $\epsilon'/\epsilon$  with accuracy in  $10^{-4}$  range by the KLOE detector [4].

To achieve this result, a luminosity  $L = 5 \cdot 10^{32} \text{ cm}^{-2} \text{ sec}^{-1}$  integrated over an effective year of  $10^7$  seconds is required.

To get such a luminosity DAΦNE is designed as a high current double ring system with a maximum number of 120 bunches/beam.

The high current approach, adopted also by PEP-II [5], allows to use single bunch parameters quite conservative from an accelerator physics point of view, but it moves the difficulties to engineering challenges (vacuum, RF, multibunch).

In DAΦNE electrons and positrons are stored in two separated storage rings laying in the same horizontal plane with horizontal crossing in  $2 \times 10$  m long interaction regions, at an angle of  $\pm 12.5$  mrad.

The main DAΦNE parameters are shown in Table II.

The regular lattice of each ring consists of 4 achromats, each housing a 2 m long, 1.8 T normal conducting wiggler to increase beam emittance and radiation damping.

The straight sections orthogonal to the interaction regions are used for injection, RF, feedbacks and a scrapers system [6] optimized for reducing the lost particles background inside the detectors.

The betatron tune working point [7], with equal vertical betatron phase advance between the two interaction points, is almost insensitive to resonances and shows negligible beam blow-up.

The second interaction region is assigned to a smaller size detector, FINUDA [8], for study of hypernuclei formation and decay. The installation of three beam lines for soft X-rays [9] is also planned.

Table II - DAΦNE Main Parameters

Energy (MeV)	510.0
Trajectory length [m]	97.69
Emittance, $\epsilon_x, \epsilon_y$ [mm·mrad]	1/0.01
Beta function at crossing, $\beta_x^*/\beta_y^*$ [cm]	450/4.5
Beam-beam tune shift, $\xi_x/\xi_y$	0.04/0.04
Betatron tune, $\nu_x/\nu_y$	5.13/6.10
RF frequency, $f_{RF}$ [MHz]	368.25
Max. number of bunches, $h_{RF}$	120
Minimum bunch separation [cm]	81.4
Bunch average current [mA]	43.7
RF voltage [kV]	250
Bunch length $\sigma_z$ [cm]	3.0
Synchrotron radiation loss [keV/turn]	9.3
Damping time, $\tau_\epsilon/\tau_x$ [ms]	17.8/36.0
Luminosity [ $\text{cm}^{-2} \text{s}^{-1}$ ]	$5.2 \times 10^{32}$

## V. VACUUM SYSTEM

The DAΦNE vacuum system [10] is dimensioned for an operating pressure of  $\sim 1$  nTorr with  $\sim 5$  A of

circulating current. A design, similar to ALS, has been adopted for the vacuum vessel inside the achromat, consisting of two chambers connected through a narrow slot. The beam circulates in the first chamber, while the synchrotron radiation photons hit a system of copper absorbers located in the second one (antechamber) in such a way that more than 95% of the photon flux is intercepted in the antechamber.

The achromat vessel ( $\sim 10$  m long) is made by two halves of Al alloy 5083-H321 plates, which, after machining, are welded along the middle plane. The total weight of each chamber is  $\sim 1.5$  ton. The inner surface is mirror finished (roughness = 0.2 Ra). Figure 3 shows one half of the arc vacuum vessel, fully machined.

Right close to each copper absorber there is a pumping station based on Ti sublimation pump (TSP). In addition, sputter ion pumps are used to pump down  $\text{CH}_4$  and noble gases. The total pumping speed installed in each storage ring is  $\sim 125000$  l/s.



Figure 3: Arc Al vacuum vessel, one half, before welding at CECOM.

## VI. RF SYSTEM

The RF system of each ring consists of a normal conducting single cell cavity, fed by a 150 kW/cw klystron developed by Thomson. The klystron is protected against the reflected cavity power by a ferrite circulator.

To reduce the high order mode (HOM) impedance [11], the RF cavity is equipped with long tapered beam tubes and three waveguides (WG) to couple out the parasitic modes that are then dissipated into external 50  $\Omega$  loads. The central body of the RF cavity (see Fig. 4) is obtained from a single forged OFHC copper billet and the internal surface is fully manufactured with an automatic milling machine. Power test of the first cavity is foreseen in July 1995.

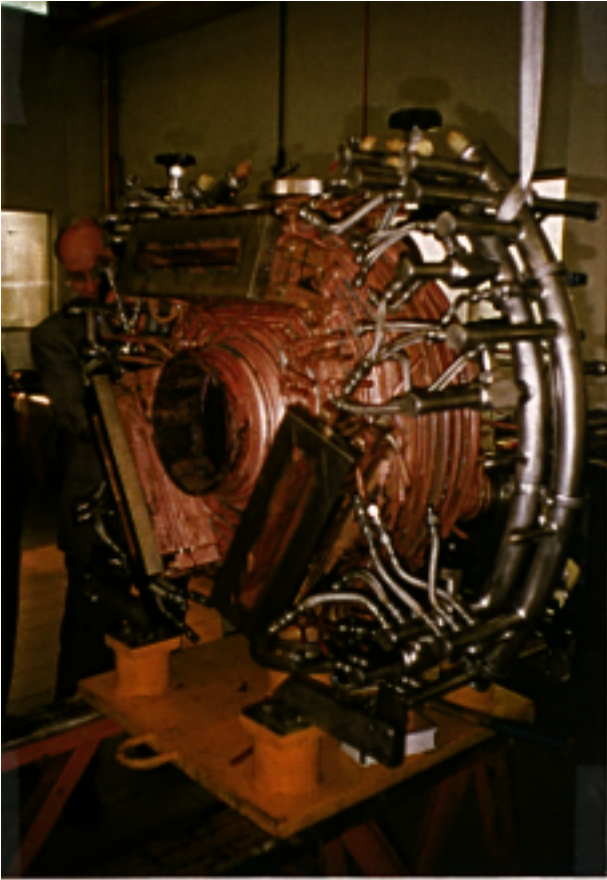

Figure 4: DAΦNE RF Cavity during fabrication at Zanon.

The low power tests, performed on a copper cavity prototype, have shown that a considerable reduction of the HOM Qs over a 2 GHz bandwidth is achieved. For symmetry reasons, the WGs, whose cut off is above the accelerating mode frequency, are applied 120° apart onto the cavity body. They are broadband transitions from rectangular WG slots to coaxial, terminated on the other side with 7/8" ceramic windows [12] which allow to dissipate the HOM power on standard 50  $\Omega$  loads in air.

The WGs (see Fig. 5), also made of OFHC copper, have been power tested successfully on bench under vac-

uum. The 7/8" coaxial output port is a wide band 50  $\Omega$  ceramic window designed at LNF.

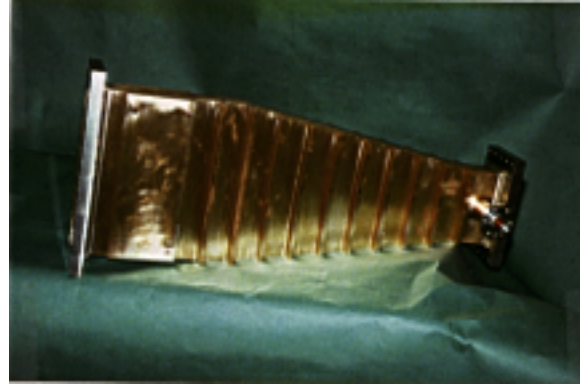

Figure 5: HOM Waveguide Transition.

The rectangular WG flanged slots on the cavity central body are clearly visible in Fig. 4.

## VII. LONGITUDINAL FEEDBACK SYSTEM

The basic design choice of achieving the required luminosity with a large total current, distributed over a large number of bunches (30  $\rightarrow$  60  $\rightarrow$  120), makes the operation very critical with respect to longitudinal coupled bunch instabilities caused by parasitic higher order modes in the ring, mainly in the RF cavity. These instabilities have been identified since the very beginning of the project as a potentially severe limit to the ultimate achievable luminosity. Even though the HOMs in the accelerating cavity are heavily damped, the probability for a damped HOM to cross a coupled bunch mode frequency is large and, due to the large total current, the growth rate of unstable modes can be stronger than the radiation damping rate by up to two orders of magnitude.

The required additional damping is provided via a time domain, bunch by bunch feedback system [13] based on digital signal processors (DSP). The digital section is under construction at SLAC in the framework of a collaboration with the SLAC-LBL PEP-II group on feedback systems for the next generation of "factories" with intense beams and a large number of bunches. In fact, the design specifications are set to meet the ultimate performance specifications of ALS, PEP-II and DAΦNE. A prototype system with a single-board digital section is running at ALS [14] and the complete modular system [13] has passed the pre-production test.

The maximum power at the kicker is determined by the voltage gain needed to achieve the required damping rate and the maximum synchrotron phase error allowed during injection.

Due to difficulties in building and tuning a stripline kicker we have designed an RF kicker with a resonant frequency of 1.2 GHz, (3.25 times the main RF frequency) [15].

Figure 6 shows a cutaway view of the cavity. The 88 mm diameter beam tube opens into a 200 mm diameter, 72 mm long, pill-box cavity. To obtain the very large

bandwidth required ( $\sim 180$  MHz at least, for 120 bunches operation), the cavity is loaded by 6 ridged waveguides followed by broadband transitions to 7/8" standard coax, very similar to those in the main RF cavity, except that in this case the coupling is extended to the fundamental mode. The 6 waveguides are placed symmetrically with respect to the accelerating mode. Three WGs are used as input ports and the other three as termination loads. In this way, thanks to the symmetry, the system is perfectly matched.

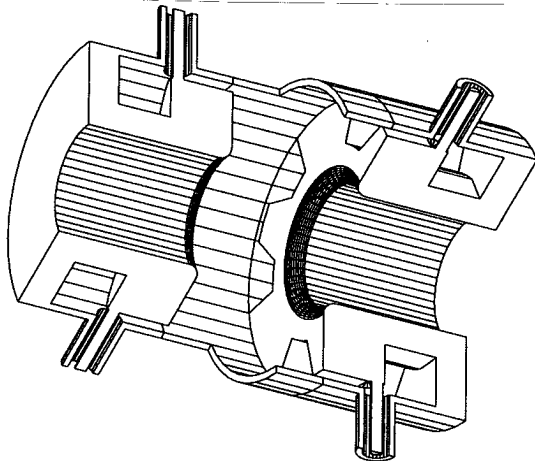

Figure 6: CAD view of the overdamped kicker cavity.

Being broadband, the kicker cavity does not need to be tuned in operation, nor cooled, since almost all the power is dissipated in the external loads. Moreover, the damping waveguides couple out the HOMs as well.

Not being the kicker cavity a directional device like the stripline kicker, it extracts power from the beam. Ferrite circulators are then necessary to isolate the output section of the power amplifier feeding the cavity.

The geometry of the kicker cavity has been defined. A peak shunt impedance of  $750 \Omega$ , together with a bandwidth larger than 220 MHz, have been calculated with 3D simulations with the HFSS code by HP. The mechanical design is under preparation at LNF and we intend to place an order to industry for two pieces (one per ring) for the initial operation at a reduced number of bunches. According to simulations with realistic values of the HOM impedances, a large band-width power amplifier of  $\sim 200$  Watt is enough to damp an initial offset of 100 ps of the injected bunch with the other 29 bunches at the full design current. Two cavities per ring will eventually be installed for operation at the full nominal current with a  $3 \times 200$  Watt power amplifiers per cavity, each feeding separately a waveguide coupler.

## VIII. ACKNOWLEDGMENTS

I like to thank the DAΦNE Machine Review Committee (A. Hutton - Chairman, F. Bonaudi, D. Boussard, G. Brianti, J.P. Delahaye, A. Wrulich) for their constant advice; E. Iarocci - LNF Director, D. Federici

and F. Pacciani - LNF Administrative Office, for their continuous support to this Project.

I am also pleased to acknowledge all the personnel of the LNF Accelerator Division for their enthusiastic commitment, and the cheerful Pina Possanza for her outstanding secretarial and administrative management.

## IX. REFERENCES

- [1] The DAΦNE Project Team, "DAΦNE, The Frascati Φ-factory", Proceedings of PAC93, p. 1993.
- [2] K. Whitham et al., "Design of the  $e^+ e^-$  Frascati Linear Accelerator for DAΦNE", Proceedings of PAC 93, p. 611.
- [3] K. Whittam et al., "Installation and Commissioning of the  $e^+ e^-$  Injector for DAΦNE at Frascati", these Proceedings.
- [4] The KLOE Collaboration, "KLOE, a General Purpose Detector for DAΦNE", Frascati Internal Note LNF-92/019 (IR), April 1992.
- [5] J.T. Seeman, "PEP II, Status and Plans", these Proceedings.
- [6] S. Guiducci, "Background evaluation in DAΦNE", DAΦNE Technical Note IR-6 (1995).
- [7] M.E. Biagini, M. Zobov, "A better working point for DAΦNE", DAΦNE Technical Note G-32 (1995).
- [8] The FINUDA Collaboration, "FINUDA, a Detector for Nuclear Physics at DAΦNE", Frascati Internal Note LNF 93/021 (IR), May 1993.
- [9] A. Balerna et al., "DAΦNE-L: Proposta per l'utilizzazione di DAΦNE come sorgente di luce di sincrotrone", Frascati Internal Note LNF-91/083 (IR), October 1991.
- [10] V. Chimenti et al., "The DAΦNE Main Ring Vacuum System", Proceedings of PAC 93, p. 3906.
- [11] S. Bartalucci et al., "Analysis of Methods for Controlling Multibunch Instabilities in DAΦNE", Particle Accelerator, Vol. 48, 4 (1995), p. 213.
- [12] R. Boni et al., "A Broadband Waveguide to Coaxial Transition for High Order mode Damping in Particle Accelerator RF Cavities", Particle Accelerator, Vol. 45, 4 (1994), p. 195.
- [13] G. Oxoby et al., "Bunch by Bunch Longitudinal Feedback System for PEP-II", Proc. of 4-th European Particle Accelerator Conference, London 1994, p.1616.
- [14] J. D. Fox et al.: "Operation and Performance of the PEP-II Prototype Longitudinal Damping System at the ALS", these Proceedings.
- [15] A. Gallo et al., "Overdamped Cavity for the DAΦNE Longitudinal Feedback", DAΦNE Technical Note, in preparation.