

NEW RESULTS OF THE 7 GHz PULSED MAGNICON AMPLIFIER INVESTIGATION *

E.V. Kozyrev, O.A. Nezhevenko, A.A. Nikiforov, G.N. Ostreiko, B.Z. Persov,
G.V. Serdobintsev, S.V. Schelkunoff, V.V. Tarnetsky, V.P. Yakovlev,
I.A. Zapryagaev, Budker Institute of Nuclear Physics
Novosibirsk, Russia

Abstract

The report presents experimental results obtained on 7 GHz pulsed magnicon amplifier and plans for the next investigations. This magnicon was developed at INP as a prototype of a microwave power source for the next generation of linear colliders. The tube operates in frequency-doubling mode of the drive signal. At present time the following parameters are achieved: maximum output power of 55 MW, efficiency of 56%, gain of 72 dB.

1 INTRODUCTION

The work on creation of scanning-beam microwave amplifiers is carried out at INP since 1967. This new class of devices right from the start of its development was intended for high efficient power supply of accelerators. In 1970 at INP the first device of that type called gyrocon [1, 2] was created. Further development of scanning-beam microwave amplifiers has been made possible with invention and development of magnicons [3]. The first magnicon – a prototype of continuous (quasi-continuous) microwave amplifier was built and tested in the 1980s at INP [3] and showed the record electron efficiency of 85% at a frequency of 915 MHz with pulse duration of 30 μ s and the power of 2.6 MW.

In the beginning of 1990s at the Institute the work was started on the development of the improved magnicon version. That magnicon was proposed as a prototype of the microwave power source for linear colliders [4]. A schematic diagram of the device is shown in Fig.1. It includes: electron gun, RF-system, magnetic system, and collector. The tube operates at 7 GHz in frequency-doubling mode, so the RF system consists of the series of deflecting cavities (the first externally driven) for beam modulation at 3.5 GHz and output cavity for conversion of beam energy into the microwave power at the second harmonic (7 GHz).

The prime object of this device investigation was to show its serviceability and ability to provide the parameters which are required from present-day microwave sources. The design parameters are listed in Table 1.

The difficulty in achieving the desired parameters was well recognized at the beginning of our work. Thus the creation of software for simulation of electron optics, electromagnetic systems, and electron beam dynamics in both

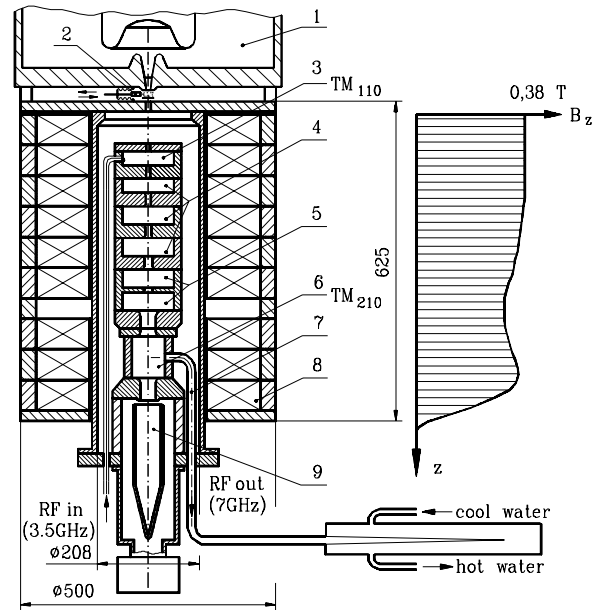

Figure 1: Schematic layout of the magnicon: 1 – electron source; 2 – vacuum valve; 3 – drive cavity; 4 – gain cavities; 5 – penultimate cavity; 6 – output cavity; 7 – waveguide ($\times 2$); 8 – solenoid; 9 – collector.

Table 1: Design parameters

Operating frequency	7 GHz
Drive frequency	3.5 GHz
Output power	50–60 MW
Gain	55 dB
Pulse duration	1.5–2 μ s
Efficiency	50–60%
Beam voltage	420 kV
Beam current	240 A

steady state and time dependent regimes was carried out simultaneously with an experimental study. Computer codes SAM, SuperLANS [5, 6] as well as codes for simulation of steady-state and time-dependent magnicon operation conditions [7] have been created and refined. An electron source with unique parameters [8] has been manufactured and successfully tested. Various versions of the design of the tube and its individual components [4] have also been

* Work is supported by Russian Fund of Basic Research

studied.

2 EXPERIMENTAL STUDIES

From the simulation and experimental results it has been found that an electron beam size and matching its optics with the DC magnetic field are the determining factors of magnicon efficiency. In 1996, the electron source was modernized by changing the geometry of gun focusing electrode, the matching between the electron beam and tube's magnetic system was also improved. The maximum value of DC magnetic field for optimal device operating is 0.38 T. In this case scalloping of the beam transverse size in the magnetic system lies in the range from 1.9 to 2.5 mm. As a result of these improvements in 1997 an output power of 46 MW was achieved with an electron efficiency of 49% and gain of 62 dB [9].

It also has been found that the magnicon electron efficiency significantly drops due to the longitudinal inhomogeneity and azimuthal asymmetry of RF fields in the output cavity, which are caused by the coupling holes with waveguide power outputs [10]. These built-in outputs are located on the cylindrical surface and spaced 135 degrees apart by azimuth and produce both azimuthal asymmetry and longitudinal inhomogeneity of RF field. These problems were solved with the special design of the output cavity (see Ref. [10]).

With all of these improvements the present experimental results as shown in Table 2 are very close to the design goals.

Table 2: Achieved parameters

Operating frequency	7.005 GHz
Drive frequency	3.5025 GHz
Output power	55 MW
Gain	72 dB
Pulse duration	1.1 μ s
Efficiency	56%
Beam voltage	427 kV
Beam current	230 A

Oscillograms of the pulses, experimental and calculated curves are shown in Fig.2-3. Parameters obtained at the device optimal operating regime are marked by “•” symbol. The output power calibration was carried out by calorimetric measurements of an average level of RF signal passed through the waveguide vacuum loads (there are no waveguide windows).

An output cavity with a loaded Q-factor $Q_l=230$, which is somewhat higher than the optimal value $Q_l=180$, was used in experiments, (seen from the calculated curve in Fig.3a) that decreases the device efficiency by 2%. The increased Q-factor has been chosen in order to shift from the region of possible instability causing a sharp efficiency drop. A small difference between the frequency character-

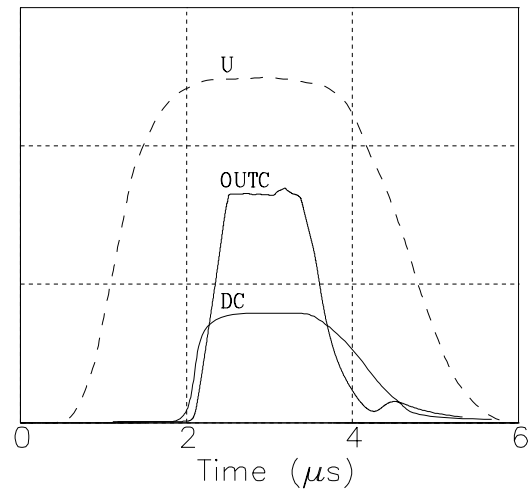

Figure 2: Oscillograms: U — beam voltage; DC — drive cavity signal; OUTC — output cavity signal.

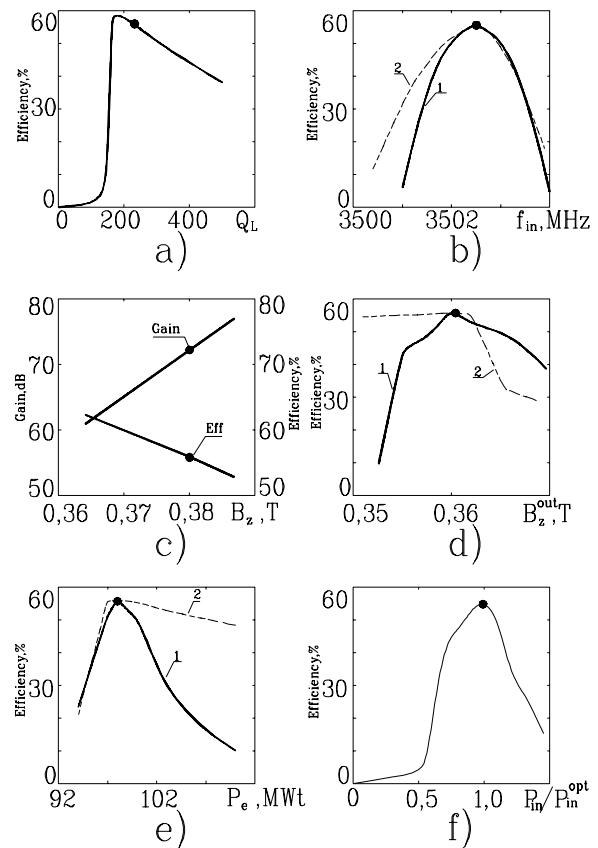

Figure 3: Experimental and calculated curves: a) loading dependence; b) input frequency dependence; c) DC magnetic field dependence of gain and efficiency; d) output cavity DC magnetic field dependence of efficiency; e) beam power dependence of efficiency; f) efficiency versus drive power. 1 corresponds to experimental data, 2 — to simulation results.

istic curve and simulation results (Fig.3b, curve 2) is due to non-optimal tuning of drive cavity input circuits.

Simulation results show that increasing in efficiency can be achieved by decreasing DC magnetic field (Fig.3c). Therewith a gain drops but still remains high enough. In the given series of experiments we was not able to decrease DC magnetic field significantly, for a beam quality is impaired because of mismatching. However, since the magnetic system solenoid consists of two sections powered by individual sources, dependence between an efficiency and magnetic field value in the output cavity area has been studied (Fig.3d). It can be seen that experimental data are in good agreement with simulation results at minor variations of that field when change of the beam optics in the deflecting system may be ignored.

We did not achieve the designed output pulse length yet. One of the reasons is associated with a strong dependence between the efficiency and beam power. Figure 3e) shows calculated and experimental curves obtained at fixed values of DC field and drive signal. Difference between them within non-optimal areas may be explained by the fact that the calculations were carried out for a fixed beam optics. That optics corresponds to the optimal operating regime. Simulation of the signal shape at the given beam power dependence of efficiency shows, that for the voltage pulse of given shape the output signal length is limited by 1.5 μ s. This problem can be overcome by improving the voltage pulse shape on the gun. Another possible reason is related to excitation of 0-type oscillation in a penultimate cavity. The penultimate cavity consists of two cavities coupled through the central hole (coupling coefficient is 0.7%). The operating mode for this cavity is π -mode. However, simulation results show, that in spite of a high value of Q-factor, 0-mode limits a pulse length of the output signal at a level of 0.8–1.2 μ s. This effect was detected in the course of 11.424 GHz magnicon development at Omega-P [11]. At present time we design a new penultimate cavity, which will allow us to remove this restriction.

3 SUMMARY

In the latest series of experiments on 7 GHz magnicon almost all design parameters have been achieved. Experimental data are in an excellent agreement with simulation results. Achieved results allow to consider a magnicon as an alternative power source for linear colliders applications interchangeably with the best modern klystrons even at present time.

4 REFERENCES

- [1] G.I.Budker et al., Particle Accelerators vol. 10, 1979, pp. 41–59.
- [2] O.A.Nezhevenko, in IEEE Trans. of Plasma Science vol. 22, No. 5, 1994, pp. 756–772.
- [3] M.M.Karliner et al., NIM, vol. A 269, No. 3, 1988, pp. 459–473.
- [4] E.V.Kozyrev et al., Particle Accelerators vol. 55, 1996, pp. 55–64.

- [5] B.Fomel, M.Tiunov, and V.Yakovlev, in Proc. XIII Int. Conf. on High-Energy Accel., vol 1, 1987, pp. 353–355.
- [6] D.Myakishev and V.Yakovlev, in Proc. of Part. Acc. Conf., Dallas, 1995.
- [7] V.Yakovlev et al., in Proc. of Part. Acc. Conf., Dallas, 1995.
- [8] Y.V.Baryshev et al., NIM, vol. A 340, 1994, pp.241-258.
- [9] E.V.Kozyrev et al., in Proc. PAC'97 Conf. (to be published).
- [10] O.A.Nezhevenko et al., in AIP Conf. Proc. 398, 1997, pp. 912–919.
- [11] O.A.Nezhevenko, V.P.Yakovlev (private communication).