

PULSED MAGNET POWER SUPPLIES FOR IMPROVED BEAM TRAJECTORY STABILITY AT THE APS*

B. Deriy[#], L. Emery, A. Hillman, G. Sprau, J. Wang, ANL, Argonne, IL 60439, U.S.A.

Abstract

New power circuit and control electronics have been implemented in the septum magnet power supplies (SMPSs) at the Advanced Photon Source (APS). The goal is to meet a low pulse-to-pulse relative amplitude jitter of about $\pm 5 \times 10^{-4}$ for trajectory stability in the booster-to-storage-ring transport line. The original power supply design produced a jitter of $\pm 15 \times 10^{-4}$, which made injection tuning difficult. After upgrade of two booster beam extraction SMPSs, the jitter is now 1.1×10^{-4} , as inferred by a beam-based statistical analysis. A common design is made for all of the septum magnet power supplies at the APS. The results achieved will be discussed along with existing issues requiring future improvement.

INTRODUCTION

It is generally recognized that, given the small horizontal acceptance of the storage ring (SR), an effective storage ring injection requires the injection beam to be steering horizontally as close as possible to the injection point aperture (at the end of the storage ring septum) without causing too much particle loss. (Obviously the beam has to be centered vertically in all apertures as well. This is not considered a difficult problem, so we'll ignore the vertical plane here.) If a beam is to pass very close to an aperture in general, then its position should be reproducible at every pass, otherwise some beam will be scraped away at the aperture by random amounts each time it passes.

There were two recent hardware improvements in the booster-to-storage-ring (BTS) beamline that facilitated this critical steering adjustment: completely new beam position monitor (BPM) electronics and new regulators for the SMPSs. In January 2003 the BTS BPM electronics was completely replaced, reducing the reading noise from 0.5 mm rms to 15 μ m. This better resolution allowed a statistical characterization of septum power supply jitter that is much improved from previous years.

There are six SMPSs at the APS – two for the booster beam extraction (B:ES1 and B:ES2), two for the SR beam injection (S:IS1 and S:IS2), one for the booster injection (PTB:IS), and one for the particle accelerator ring (PAR) injection and extraction (PAR:PSP).

The new power circuit and the instrumentation details of the upgrade with significantly better voltage regulation performance were already described in [1] and will be omitted here. The timeline of the upgrade was as follows.

In September 2005, the booster septum power supplies B:ES1 and B:ES2 were upgraded. In January 2006 the SR septum power supplies S:IS1 and S:IS2 were upgraded as well, solving most of the problems with our ability to tune SR injection. The PAR-to-booster injection SMPS was upgraded in May 2006.

This paper presents the data for the BTS beamline for three periods, as shown in Table 1. We will first briefly describe the statistical analysis method on the BTS trajectory.

Table 1: The Data Acquisition Timeline

Period	Conditions		Date of Data
	BPMs	Septum	
Jan 1995 - Dec 2002	Original	Original	Mar 2, 2001
Jan 2003 - Aug 2005	New	Original	Feb 12, 2003
Sep 2005 - Now	New	New	Oct 2, 2005

ANALYSIS METHOD

A plot of a BPM readback as a function of pulse number will produce a spread of readings, which is the sum of the instrument noise and the actual beam position jitter. If slow or DC drift is present, it is filtered out from the data before doing jitter analysis, as the drift will make the estimated noise larger than it really is. Because multiple BPMs in the beamline are available, it is possible to use a standard statistical analysis called Principal Components Analysis (PCA). It uses singular-value matrix decomposition (SVD) to separate the real trajectory jitter from the instrument noise. This idea was introduced in accelerators in [2] and is repackaged as Model-Independent Analysis (MIA) (the Accelerator Handbook reference is found in [3]). Emery expanded the usefulness of MIA by including the “model” into the analysis [4]: a beamline model was created with simulated trajectory jitter and instrument errors of some amplitude, then the simulated BPM readbacks were SVD-analyzed, just like the experimental data. A fit of the model parameters (jitter source amplitudes) was done to make the model SVD results agree with those of the measurement.

The optics model used for the BTS beamline is the standard optics model of dipoles and quadrupoles, with the program **elephant** [5] generating possible trajectories through the beamline. The bending angle and focusing strength are fixed.

The booster beam extraction thick and thin septa (B:ES2 and B:ES1) are given a uniform random fractional strength error. The amplitudes of the errors are two adjustable parameters of the model. The BPMs are inserted in the beamline model at their appropriate locations, and given a readback Gaussian noise of some

* Work supported by U. S. Department of Energy, Office of Science, Office of Basic Energy Sciences, under Contract No. W-31-109-ENG-38.

[#]bderiy@aps.anl.gov

amplitude, which is another adjustable parameter. In one set of experimental data a booster energy jitter was included in the model, since it appeared that the booster ramp was noisy (measured at relative error of 0.6×10^{-4} with new BPMs). Since the main result of SVD, the singular values, scale with the square root of the number of samples, the model should be simulated with the same number of samples as the experiment.

Using the notation of [3], we take P samples of M synchronized BPMs, $b(t_p) = (b_p^1, b_p^2, \dots, b_p^M)$, and arrange the data as a matrix,

$$B = \begin{pmatrix} b_1^1 & b_1^2 & \dots & b_1^M \\ b_2^1 & b_2^2 & \dots & b_2^M \\ \dots & \dots & \dots & \dots \\ b_p^1 & b_p^2 & \dots & b_p^M \end{pmatrix}. \quad (1)$$

Do the SVD decomposition of this matrix UAV^T . U has the same dimension as B . A is a square $M \times M$ matrix, and V is another $M \times M$ square matrix. The columns of U and V are orthonormal.

A is a diagonal matrix of positive eigenvalues or singular values (SVs) with values λ_m , $m = 1, \dots, M$. The columns of V , v_m , are the spatial modes, or trajectory-like pattern modes that are valuable to investigate. The columns of U , u_m , are the time patterns of each of the M trajectories (spatial modes). The length of the u_m is the number of sample points, P .

To declare that the model agrees with the experiment, both the singular values and the spatial mode vectors v_m should agree. The level of agreement is subjective as there may not be an exact fit. Many aspects of the model are assumed: ideal knowledge of beamline optics, ideal BPM calibration, and ideal and identical noise distribution of all BPMs.

In a typical beamline trajectory analysis, one expects one singular value corresponding to each independent perturbation source. In this case we could expect two sources from the two independent septa, or just one if the two septa are so close that the system of BPMs as a whole cannot resolve their trajectory components. Both the eigenvalues and eigenvectors for the sources should agree. The rest of the singular values represent the uncorrelated noise of the BPMs and are much smaller and usually close in value. The singular values of the BPM noise of the measurement and the model should roughly agree but the eigenvectors need not necessarily agree. The model parameter that controls this “lower” part of the spectrum (the lower singular values) is the BPM noise amplitude. If there are some weak noise sources, they may be buried in these eigenmodes and not seen.

DATA

Figure 1 shows the evolution of the BPM data over the years. The two BPMs that have the most response to septum jitter are plotted against each other. The leftmost

graph represents the conditions from 1995 to 2002. The middle plot shows data with the BPM electronic improvements only. Here the analysis resolved the amplitudes of each septum because the BPM noise was small and the jitter was large. The right plot shows a much-reduced trajectory noise from the improvement of the septum jitter. Now that the jitter amplitude is small, and the analysis no longer distinguishes the two septum jitter sources, there is only one singular value that is visible, i.e., above the noise singular values.

More details on resolving septum jitter contribution in the trajectory data should be mentioned. Simulations with low or zero-noise BPMs show that the largest eigenvector looks like the average trajectory produced by the septa. The other eigenvector looks like the difference of the trajectories. Assuming equal-amplitude jitters for the septa, the resulting two eigenvectors from septa “sum” and “difference” mode have singular values that differ by a factor of 19, an indication of how close to equivalent the septum locations are. The factor is even larger for unequal amplitudes. We can expect that the septum jitters can only be resolved when the jitter amplitude is large relative to BPM noise amplitude.

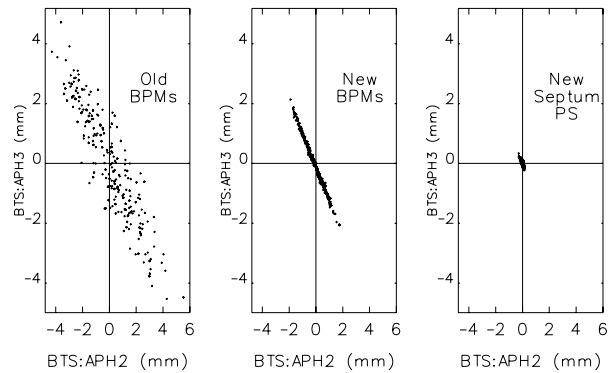

Figure 1: Evolution of BPM data over the years. The two BPMs are located at high β_x and are about π phase apart.

FIT OF MODEL

The model parameter fit is listed in Table 2. The spectrum of singular values of experimental data for the three different conditions is shown in Figure 2.

Table 2: Jitter Amplitudes Fit to Measurements

Conditions	Original BPMs Original Septum	New BPMs Original Septum		New BPMs New Septum
Thick septum [†]	2×10^{-3}	0.7×10^{-3}	1.5×10^{-3}	1.1×10^{-4}
Thin septum [†]	2×10^{-3}	2.1×10^{-3}	1.1×10^{-3}	1.1×10^{-4}
Energy	Below detection	1.0×10^{-4}	1.0×10^{-4}	
BPM noise [‡]	1.5 mm	30 μ m	30 μ m	15 μ m

[†]Septum amplitude is \pm amplitude of uniform error distribution. To get rms, divide by $\sqrt{3}$.

[‡]BPM noise is rms of Gaussian noise.

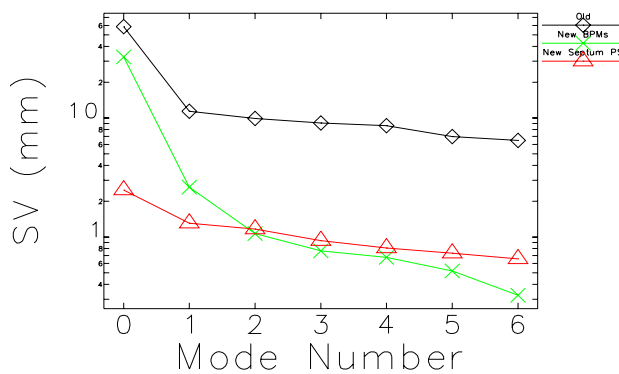

Figure 2: Spectrum of singular values of experimental data.

For the middle condition, with new BPMs and original septum, there are two data sets that are shown in separate columns. The data under the first three headings were taken before the septum upgrade. The variation in results indicates the accuracy of the fitting. The last column contains data taken after the septum upgrade, which show an improvement of a factor 10 to 15 in beam stability.

KNOWN DEFICIENCIES AND FUTURE IMPROVEMENTS

The Booster Dipole Ramp

An additional source of noise in the BTS trajectory is the occasional regulation problem of the booster dipole ramp, which produces some jitter in the beam energy. This jitter has been evaluated from ramp data and from statistical analysis on the beam. It is very small in general and doesn't affect injection.

The Thermal Effect

The booster septum pulse amplitude drift due to temperature change in the magnet is another source of BTS trajectory error, but it is correctable with a feed-forward based on the pulsing history of the magnet. Presently an MCR workstation handles this. In the vertical plane, the jitter and DC drift are small and have not caused a problem with injection. The thin septa (S:IS2 and B:ES1) show no thermal effects when pulsing at 2 Hz for a long time. Thus voltage regulation appears to be sufficient for these power supplies. The thick septum magnet in the SR (S:IS1) has little thermal effect when operating in top-up mode by pulsing once every two minutes. Both the SMPS and magnet operate at ambient temperature equilibrium.

The feedforward process will be handled in the septum hardware after the next phase of the septum PS upgrade.

Future Improvements

The algorithms and the prototype of a fully digital system for the shot-to-shot magnet current regulation with at least 10^{-4} precision have already been designed. There are three embedded microprocessors in the system. One embedded microprocessor is responsible for closed-loop regulation of capacitor bank voltage. Another microprocessor is providing the feedforward correction based on the magnet current waveform reconstruction measured during discharge. Communication with the network is performed by an embedded EPICS controller. The time resolution for signals regulating the power supply is 10 ns. We plan to implement the new system shown in Figure 3 in booster supplies before the end of 2006.

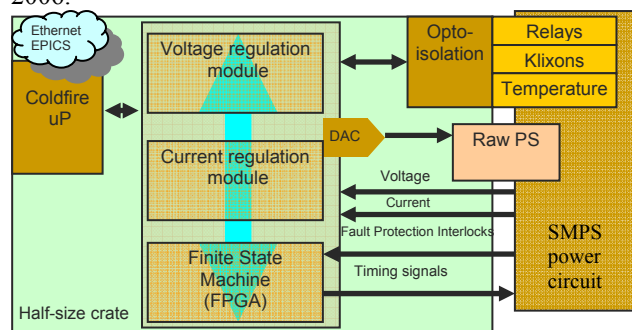

Figure 3: The new SMPS block diagram.

REFERENCES

- [1] B. Deriy, A. Hillman, G. Sprau, J. Wang, "The APS Septum Power Supplies Upgrade," Proceedings of the 2005 Particle Accelerator Conference, Knoxville, TN, 2005, p. 3795, <http://www.jacow.org>.
- [2] J. Irwin et al., Phys. Rev. Lett. 82 (1999) 1684.
- [3] J. Irwin, *Handbook of Accelerator Physics and Engineering*, World Scientific, Edited by A. Chao, M. Tigner, 278 (1999).
- [4] L. Emery, "Application of Model-Independent Analysis using the SDDS Toolkit," Proceedings of the 2003 Particle Accelerator Conference, Portland, OR, 2003, p. 3464, <http://www.jacow.org>.
- [5] M. Borland, "elegant: A Flexible SDDS-Compliant Code for Accelerator Simulation," Advanced Photon Source Note LS-287, September 2000.