

STATUS OF THE DIAMOND STORAGE RING RADIO FREQUENCY SYSTEM

M.R.F Jensen, M. J. Maddock, S. A. Pande, A. Rankin, S. Rains, D. Spink, A. Watkins,
Diamond Light Source Ltd, Oxfordshire, UK.

J. Alex, M. Mueller, Thomson Broadcast & Multimedia AG, Spinnereistrasse 5, PO Box, CH-5300,
Turgi, Switzerland

M. Pekeler, ACCEL Instruments GmbH, Forschungsausrüstungen, Friedrich-Ebert Strasse 1, 51429
Bergisch Gladbach, Germany

B. Aminov, CRYOELECTRA GmbH, Wuppertal, Germany

Abstract

The installation and commissioning of the Diamond Storage Ring RF system is nearing completion. Diamond will initially operate with two RF high power amplifiers and two cavities. The key components in each RF system are a 300 kW amplifier implemented through the combination of four 80 kW IOTs, a 500 MHz superconducting cavity providing up to 2 MV of accelerating voltage and an advanced analogue IQ Low Level RF (LLRF) system to control the cavity frequency, voltage and phase. We present here an update on the recent installation and early commissioning results of the RF systems.

1 MeV from the bending magnets and up to an additional 0.78 MeV from the IDs. However the first Storage Ring commissioning took place at 700 MeV. Table 2 shows the RF related parameters for 3 GeV and 700 MeV operation.

Table 2: Key RF parameters for nominal and early Storage Ring commissioning

	3 GeV	700 MeV
RF Frequency	499.654 MHz	
Harmonic number	936	
Nominal beam current	300 mA	2 mA (max)
Loss per turn in dipoles	1 MeV	3 keV
Cavity voltage (no IDs)	3.0 MV	0.3 MV
RF bucket	4.6 %	4.1 %
Synchronous Phase	19.6°	0.6°
RF Forward power	311 kW	1.07 kW
Power to beam	300 kW	6 W

INTRODUCTION

The Storage Ring Radio Frequency system is designed to operate initially with two RF systems and two cavities for early operation up to 300 mA but for higher beam currents and with future Insertion Devices (IDs), a third amplifier and cavity will be required. The Master Oscillator and RF distribution [1] provides the source RF signal used for each amplifier chain (see Fig. 1).

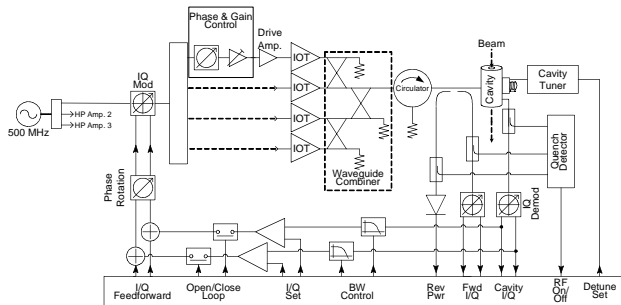

Figure 1: Schematic showing the key RF components in the RF chain

The installation of the LLRF, the High Power Amplifiers and first two superconducting cavities have been completed and the commissioning of the systems is close to being complete. The nominal energy of Diamond is 3 GeV and the RF system has been designed to operate with a nominal current of 300 mA with radiation losses of

HIGH POWER AMPLIFIERS

Three off 300 kW amplifiers have been designed and installed by Thomson Broadcast & Multimedia [2]. RF commissioning of the first two systems has started with the first system having been fully commissioned up to 250 kW. Each amplifier system is deemed to include reject loads on the combiner, the circulator and the main reject load. During the commissioning a variety of trips have been observed. Following some spurious tripping due to signal pickup, small arcs in the main reject load and sudden increases in drive from the drive amplifiers, the remaining RF trips have been in the input and output cavities of the IOTs. Typically the system would operate for 1-8 hours until an external, audible arc would trip off the system. Due to operational constraints the amplifier was commissioned at 250 kW. At this power level no arcing was observed. The arcing at full nominal power has been reduced by improving the voltage hold-off through the re-design of the high voltage contactors. Following the modifications the visible marking (see Fig. 2), caused by the arcing, has been overcome and no additional damage has been observed on the IOTs.



Figure 2: Evidence of arcing around the output ceramic on an IOT.

A further source of tripping was arcs in the input cavity, again only observed at full rated power. Closer examination revealed small deposits of fine building dust getting through the air filters and being deposited at critical high voltage areas in the input cavity. Thomson and Thales Electron Devices proceeded with a part redesign to improve the voltage hold off though additional potting material, some re-shaping of high voltage electrodes and by re-directing the cooling airflow to prevent dust being deposited in areas of high potential fields. The first four input cavities were modified and a long term test at the full nominal power of 300 kW was started. The system operated for 16 hours before tripping, due initially to a faulty drive amplifier and later it tripped on an over temperature interlock, caused by a failure of the temporary water cooling supply. Neither of these trips were caused by the high power amplifier. The full power test at 300 kW will be recommenced as soon as the cooling water becomes available. Table 3 summarises some of the main performance parameters. Particularly noticeable are the high overall efficiency, due to the high efficiency power supply and the high conversion efficiency of each IOT, the fast switch off response without the use of a crowbar, as well as the impressive RF performance.

Table 3: High power amplifier RF performance

Total electrical efficiency (250 kW)	61%
Voltage ripple @ 150 kW, 8.8A	5 V _{rms}
Voltage ripple @ 300 kW, 12.6 A	8.5 V _{rms}
Noise @ 1.56 kHz (switching frequency of power modules)	< -70 dBc
Noise @ 100 kHz (PWM frequency of voltage regulation)	< -70 dBc
Fast switch off time for external trip	28.4 μs
Harmonics (250 kW, f ₀ =500 MHz)	2f ₀ -60 dBc
	3f ₀ <-70 dBc
	4f ₀ -58 dBc
	5f ₀ -63 dBc

Here the efficiency is the ratio of the RF output power measured in the reject load to total power input to the

amplifier. The efficiency therefore includes power supply losses, power supply air conditioning, auxiliary supplies, secondary circuit water pump and two passes through the circulator. Not included is the drive power for each IOT.

CAVITIES

ACCEL Instruments GmbH has delivered three Cornell-type 500 MHz superconducting cavities to Diamond. The cavities are supplied with LHe from a Helial 2000 refrigerator supplied by Air Liquide DTA. Two cavities have been installed and the third is being kept as a spare or until required for high-current operation. The three cavities were tested at Cornell prior to being mounted in their cryostats. Fig. 3 shows the results of the vertical test for each of the cavities. The specification of Q₀ was 5 x 10⁸ at an accelerating voltage of 2 MV (6.6 MV/m) per cavity. Q₀ from the vertical test for the three cavities in all cases exceeded the specification, although comparing the Q₀ with similar cavities produced by ACCEL for Cornell, CLS and the NSRRC, the Q₀ of the DLS cavities are slightly worse than expected.

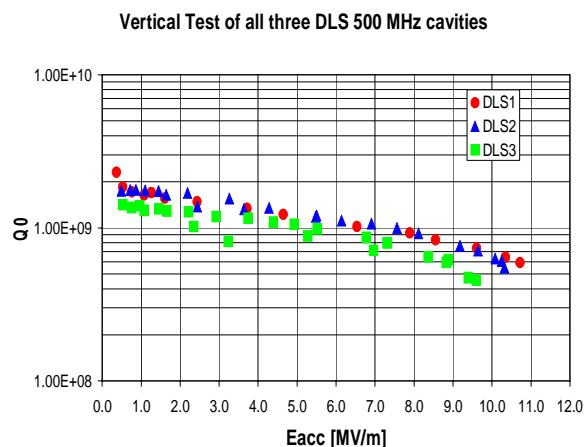

Figure 3: Results of the vertical test for each of the three cavities.

Following installation the cavities were tested at Diamond. After cool down, a long power outage forced cavity 1 to vent its entire volume and to warm up slowly. Consequently the cavity was in the elevated temperature zone between 100 K and 150 K for several days before it was cooled down again. After this unusual temperature cycle, the cavity exhibited low Q₀ which appeared not to improve significantly with conditioning. After that the cavity was warmed up to room temperature and cooled down normally within 8 hours to 4.2 K. Fig. 4 shows the improvement in Q₀ and proves that the cavity meets specification after standard cool down. The results of the Q₀ measurements of the second cavity is shown in Fig 5. Both cavities have demonstrated fields in excess of the specified 2 MV.

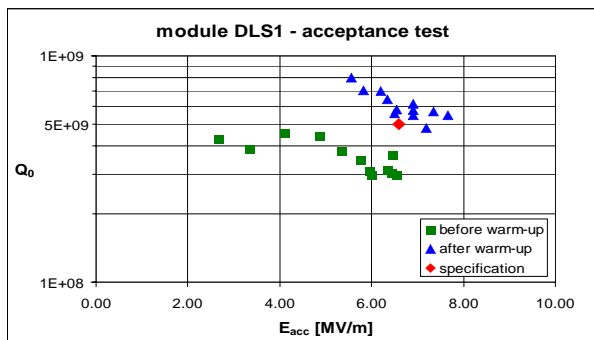

Figure 4: Q_0 of cavity 1 before and after a complete warm up and cool down.

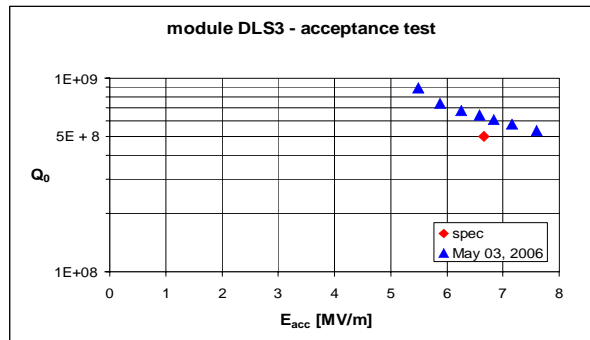

Figure 5: Q_0 of cavity 2

LLRF

The LLRF system supplied by ACCEL (Fig 6), has been partially commissioned and was used during first beam commissioning in the Diamond Storage Ring. Analogue technology is used to implement a vector (IQ) loop controlling cavity amplitude and phase and the cavity frequency is controlled through a PID regulation in EPICS. Two LLRF controllers have been installed, but hardware for a third LLRF will be integrated into the same rack later.

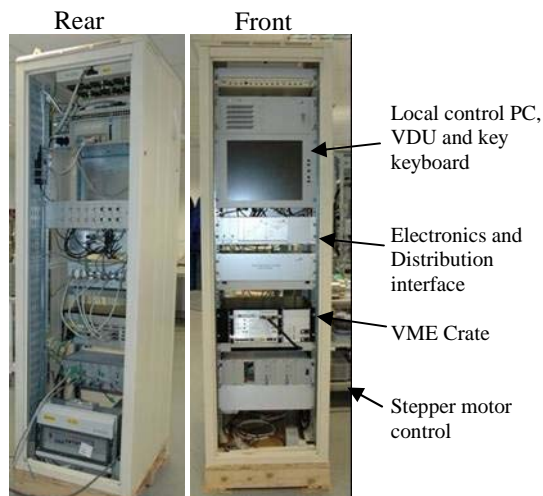

Figure 6: Front and rear view of LLRF

Commissioning of the LLRF has involved calibration of the forward and reverse (pickup) paths and cavity frequency against tuner position.

Operation of the tuner highlighted difficulties in determining suitable PID parameters to ensure that the tuner actively tracks the cavity frequency. Noticeable hysteresis and suspected stepper motor slippage is being investigated. Detuning the cavity, required for stability and later to counter beam loading, has been demonstrated to work, although some difficulties were observed at very low cavity voltages.

During the early 700 MeV beam commissioning, the LLRF has had to operate with cavity voltages as low as 20 kV, well outside the specified dynamic range. The effect of such very low voltages, low forward power and extremely low beam power requirements, not surprisingly, has produced poor signal-to-noise ratios for signals demodulated by the LLRF. Voltage and phase stability demonstrated so far, are approximately 3 or 4 times worse than the specified 0.5% rms and 0.2° rms respectively. Characterisation at normal operating conditions for 3 GeV operation is being scheduled.

The LLRF GUI (see Fig 7) provides the user with a wealth of settings and performance parameters. An operator mode is available which hides calibration functions, such as amplifier gain, cavity pickup and loop gain and bandwidth optimisation.

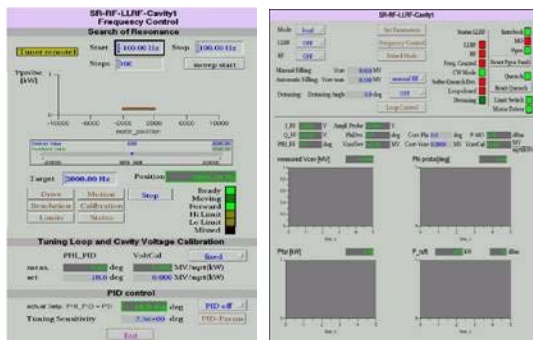

Figure 7: LLRF EPICS control screen.

CONCLUSIONS

Two high power amplifier systems, LLRF and cavities have been installed for initial operation at Diamond with a third amplifier installed and a third cavity delivered for later operation. Despite the installations and commissioning of the systems being delayed by building delays and lack of utilities, good progress has been made to overcome the early difficulties on each system. The system was initially operated with beam albeit at 700 MeV. Outstanding commissioning is nearing completion and beam commissioning at the nominal 3 GeV will be carried out shortly.

REFERENCES

[1] A. Watkins et al; 'Distribution System for the Diamond Oscillator', Proceedings of 2006 Particle Accelerator Conference, Edinburgh, 2006.
 [2] M. Jensen et al, Proceedings of 2005 Particle Accelerator conference, Knoxville, Tennessee, 2005, p1883.