

CALCULATION AND DESIGN OF THE RE-BUNCHER CAVITIES FOR THE LIPAC DEUTERON ACCELERATOR*

D. Gavela#, I. Podadera, F. Toral, CIEMAT, Madrid, Spain

Abstract

Two re-buncher cavities are necessary for the LIPAc (Linear IFMIF Prototype Accelerator), presently being built at Rokkasho (Japan). They are placed at the Medium Energy Beam Transport (MEBT) line to longitudinally focus a 5 MeV CW deuteron beam. Due to the strong space charge and the compactness of the beamline, the cavity has several space restrictions. In order to minimize the power loss, an IH-type cavity with 5 gaps was selected. It provides an effective voltage of 350 kV at 175 MHz with a power loss of 6.6 kW. First, electromagnetic calculations have been done with HFSS to compute the resonant frequency, the S-parameters, the electric and magnetic field maps, the power losses and the proper geometry for a magnetic input coupler and a pickup probe. Then, a mechanical Ansys model has been used to analyze the stresses and deformations due to vacuum, the cooling circuit and the temperature distribution, taking into account the power losses imported from the electromagnetic model. Finally, the fluid dynamics in the cooling circuits of the stems has been carefully studied.

INTRODUCTION

Two re-buncher cavities will be installed in the MEBT line [1], which is part of the Spanish contribution to LIPAC. The specifications are described in Table 1.

Table 1: MEBT re-Buncher Specifications

Parameter	Value
Frequency	175 MHz
Maximum E_0LT	350 kV
Beam pipe radius	22 mm

In a preliminary study [2] several configurations were analysed. A 5-gap IH type cavity was selected for optimization of the electric field peak, the RF losses and the feasibility of the stem cooling.

ELECTROMAGNETIC MODELLING

HFSS code, integrated in Ansys Workbench [3], has been used to perform the RF simulations. Eigenmode Analysis was performed firstly to achieve the resonance and to get the field maps. DrivenModal analysis was performed afterwards for studying the performance of power coupler and pickup probe (Fig. 1).

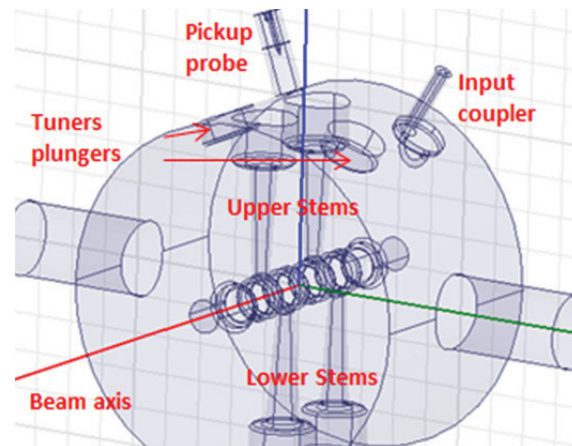

Figure 1: Geometry of the electromagnetic model.

Eigenmode Analysis

The geometrical parameters of the cavity were optimized to get the resonant frequency and to limit the electric field (a maximum of 13.9 MV/m was achieved) and surface power density. A Q factor of 11746, a shunt impedance of 9.29 M Ω and a total power loss of 6.6 kW were obtained.

Figure 2 shows the field map results of electric and magnetic fields, the electric field being concentrated mostly on the drift tube corners while the magnetic field prevails mostly on the stem walls.

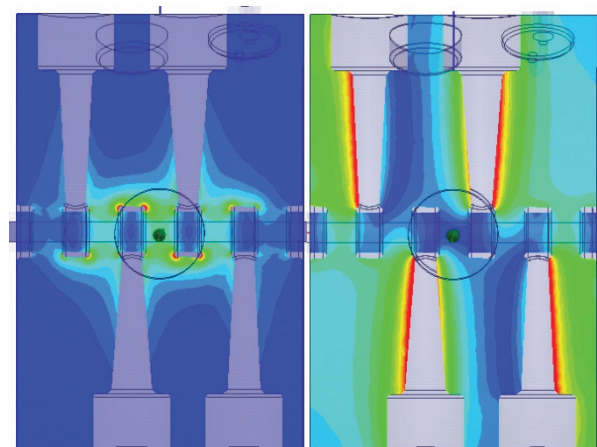

Figure 2: Electric (left) and magnetic (right) field maps.

The electric field through the beam axis is shown in Fig. 3. The central gap carries out the highest electric field, while the end gaps show a much lower field. The requested effective voltage (E_0LT) was obtained by integrating the curve considering particles with $\beta=0.073$.

*Work partially supported by the Spanish Ministry of Economy and Competitiveness under project AIC-A-2011-0654

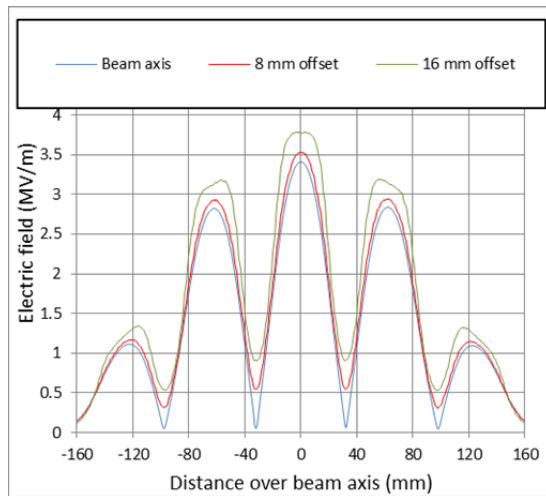

Figure 3: Electric field through the beam axis and two lines with different offsets.

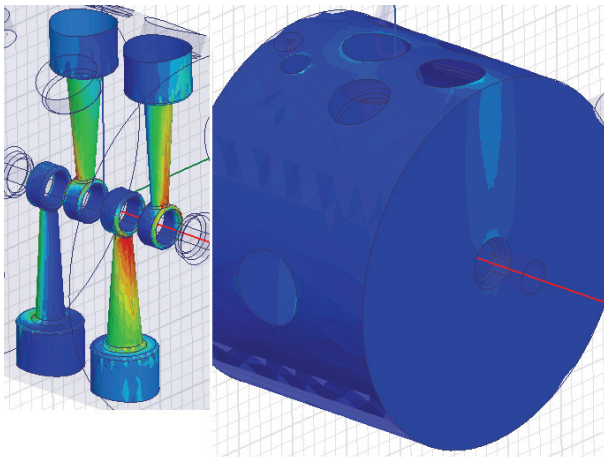

Figure 4: Surface loss over the stems (left) and inner walls of the cavity (right).

The greatest heat deposition takes place at the thin stems, which are at the sides (maximum local value of 8.9 W/cm^2). Heat deposition at the cavity walls is much lower (maximum of 3 W/cm^2), but more difficult to refrigerate as the cavity shell will be fabricated in stainless steel (internally copper coated), which has a much lower thermal conductivity than solid copper (Fig. 4).

The tuner movement effect was also evaluated. The cavity will incorporate two 80 mm diameter plungers with a stroke of $\pm 20 \text{ mm}$ around its nominal position, located in a zone with a dominance of magnetic over electric field, therefore producing an inductive type tuning. Calculations show a variation of the frequency of $\pm 408 \text{ kHz}$ by moving both tuners between their extreme positions, which is considered enough to compensate for the dimensional errors and temperature effects.

Finally the sensitivity of the frequency to the length of the stems base (cylindrical part) was evaluated. The result is 150 kHz/mm . The reason this calculation is that this dimension will be used for a fine tuning of the real cavity. In a first step, the stems will be fabricated with that dimension longer than nominal and the resonant

frequency will be measured. From that result and the sensitivity, the final value for that dimension will be decided and machined in a final turning operation.

Driven Modal Analysis

This kind of analysis evaluates the frequency response of the cavity. The performance of the power coupler and pickup probe are evaluated this way, by calculating the S-parameters.

The power coupler is of inductive type [2]. Its dimensions have been optimized for achieving the impedance matching with the cavity. The coupler loop orientation allows for some regulation around its nominal position in case the actual matching is not adequate. A very low reflection ($S_{11} < -25 \text{ dB}$) was obtained at resonance.

The pickup probe is also of inductive type. Its dimensions and location were determined to get a signal with an appropriate power level. It has been located inside a port to avoid an excessively high transmitted power. A transmission coefficient (S_{12}) between power coupler and pickup probe about -67 dB was obtained. At nominal operation, the pickup probe catches 1.3 mW .

MECHANICAL MODELLING

All the mechanical calculations were performed by using Ansys Workbench.

Thermal Calculations

The surface heat deposition calculated with the electromagnetic model has been imported as a heat load distribution into the thermal model.

Each stem will be made in one piece of OFE copper. The cooling water gets into the stem through a central hole and comes out through a concentric external conduit (Fig. 5, left). The cooling channels cannot reach the drift tubes, so the heat produced at the drift tubes has to be transferred by conduction to the nearest part of the cooling conduits.

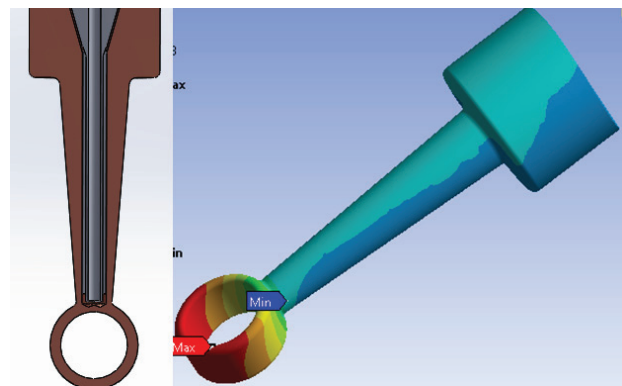

Figure 5: stems cooling overview (left) and calculated temperature distribution on a side stem (right).

The temperature distribution in the stems is calculated with the model. A $10000 \text{ W/m}^2\text{K}$ heat transmission coefficient was conservatively supposed at the cooling circuit walls. With input water at $18 \text{ }^\circ\text{C}$, the results show a

maximum temperature of 57 °C in the stems (Fig. 5, right).

As pointed out above, cooling the cavity shell is more critical than the stems. The cavity central body (cylindrical part) will be refrigerated by copper pipes soldered into a channel machined on its outer surface. The layout of that channel has been optimized through several iterations to achieve a good temperature distribution. A maximum temperature of 64 °C was obtained, near one of the central stems base (Fig. 6, left).

The cooling of the end plates will be performed by through-holes. Their number and location were also determined for achieving a proper cooling of these parts. A maximum temperature of 60 °C was obtained at the end drift tubes, which are bolted to the end plates and get cooled only by conduction (Fig. 6, right).

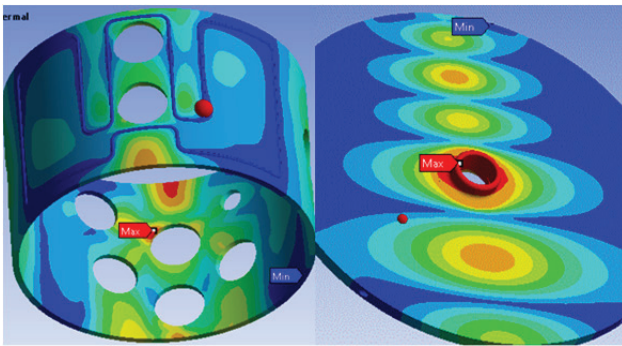

Figure 6: Calculated temperature distribution on cavity central body (left) and end plate (right)

Structural Calculations

A structural calculation was also performed to evaluate the stresses and deformations under vacuum. All the components are well below the yield stress.

Regarding the deformations, only the deformation at the end plates due to the vacuum load is not negligible. At the center, a deformation of 0.15 mm is calculated for a bonded endplate, and about 0.18 mm for a bolted one (closer to real life). The effect of this deformation on the cavity resonant frequency has also been evaluated by redoing the electromagnetic calculations with the deformed geometry. A displacement of -250 kHz was obtained. This deviation will be compensated by a slight increase in the length of the stems base (expectedly in the order of 2 mm) according to the fine tuning procedure explained in “Eigenmode Analysis” section.

Fluid Dynamics Calculations

A CFX study was performed to evaluate the water behaviour at the return point in the stems cooling system. That region is characterized by a very non-uniform distribution of velocities. A detailed study was considered important to avoid two possible unwanted effects: low velocity regions with a low wall transmission coefficient and low cooling capacity and, on the other side, too high velocity regions with the risk of a low pressure and cavitation effects.

The real shape of the bottom of the central cooling channel and the return conduit were implemented in the model. An average velocity of 4 m/s far from this area was fixed as a boundary condition. A maximum velocity of 5.25 m/s is achieved in the calculations, with a minimum wall heat transfer coefficient of 10.000 W/m²K in all the cooling surfaces (Fig. 7). The return channel geometry was optimized by this calculation.

Finally, the pressure drop in all components was calculated to decide the number and disposition of the cooling circuits. The refrigeration of the central body, the end plates, the stems, the tuners and the coupler was divided among four circuits coming out of a common water collector that were established trying to get a similar pressure drop between them. A total flow of 31.2 l/min, a 230 kPa pressure drop and a temperature increment of 3.1 °C are expected.

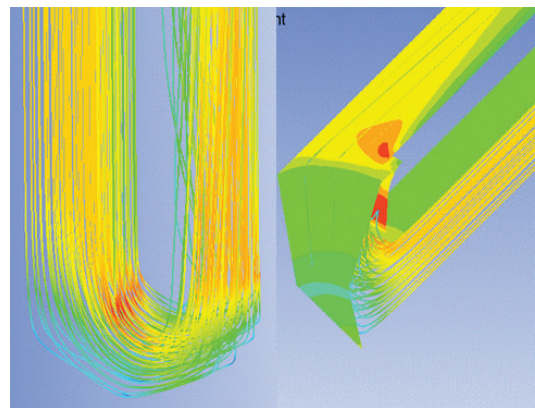

Figure 7: Calculated velocity stream lines (left) and wall heat transfer coefficient at the water return point in the stems (only 1/8 of the geometry was modelled due to the symmetry).

CONCLUSION

This paper has shown the detailed calculations performed for the LIPAc rebuncher cavities, to refine the conceptual design. The objectives (external dimensions, effective voltage, power loss, maximum local electric field, temperature, etc.) were achieved with the final design.

ACKNOWLEDGMENT

The authors would like to thank warmly A. Facco (INFN), M. di Giacomo (GANIL), A. Schempp (Frankfurt University) and M. Vretenar (CERN), for their valuable advices.

REFERENCES

- [1] I. Podadera et al., “The Medium Energy Beam Transport Line (MEBT) of LIPAc”, proceedings of IPAC2011, San Sebastián, Spain.
- [2] A. Lara et al., “RF Design of the Re-buncher Cavities for the LIPAc Deuteron Accelerator”, proceedings of IPAC2011, San Sebastián, Spain.
- [3] www.ansys.com